

PHASE THEORY AND PARAMETRIC VARIATION

by

ÁNGEL J. GALLEGO

B.A. Universitat Autònoma de Barcelona
(2002)

M.A. Universitat Autònoma de Barcelona
(2004)

Doctor of *Cognitive Science and Language*
at the
Departament de Filologia Espanyola
Facultat de Filosofia i Lletres

UNIVERSITAT AUTÒNOMA DE BARCELONA

May 2007

THESIS SUPERVISORS

Title: José M. BRUCART
Full Professor, Universitat Autònoma de Barcelona

Title: Juan URIAGEREKA
Full Professor, University of Maryland

To my father, Manuel Gallego, for supporting me

To my mother, Patricia Bartolomé, for taking care of me

Limpió con la servilleta los labios entintados.
-Bueno, ahora dime algo de ti.
Carlos se encogió de hombros y miró al vacío.
-Yo sigo viendo vivir a los demás.

La Pascua triste, Gonzalo TORRENTE BALLESTER

TABLE OF CONTENTS

Dissertation Abstract.	i
--------------------------------	---

Acknowledgments.	iii
--------------------------	-----

CHAPTER I: *The Framework*

1. Introduction.	1
2. Design Factors and the <i>Strong Minimalist Thesis</i>	1
3. Computational Operations.	6
3.1. Merge.	9
3.1.1. Bare X-bar Theory.	9
3.1.2. Labels and set Merge.	15
3.1.3. Adjuncts and pair Merge.	23
3.2. Agree.	30
4. Locality and the Concept of Cycle	42

CHAPTER II: *Phase Theory and Phase Sliding*

1. Introduction.	53
2. <i>Phase Theory</i> : Locality and Parameters.	56
2.1. Phases <i>qua</i> Numerations.	56
2.2. Phases <i>qua</i> Phase Heads.	60
2.3. Inheritance as Feature Sharing.	72
3. The Nature of Case: Consequences for Merge and Clause Structure.	77
3.1. Case as Tense/Aspect.	77
3.2. Feature Sharing and Merge	86

3.3. T-to-C Movement	92
4. Verb Movement and <i>Phase Sliding</i>	102
5. Some Consequences of <i>Phase Sliding</i>	121
5.1. Obligatory Inversion.	122
5.2. Uriagereka's (1999b) Analysis of Subjects in NSLs.	132
6. Conclusions	148

CHAPTER III: Parametric Variation in Romance

1. Introduction	149
2. Uriagereka's (1995) "F" and Parametric Variation.	151
3. On T _{def} and Subjunctive in Spanish	172
3.1. T _{def} in Spanish	175
3.2. Raising over Experiencer and Spanish <i>parecer</i>	179
3.2.1. Boeckx's (1999a; 2000a) and Torrego's (2002) Accounts	181
3.2.2. A New Analysis	186
3.3. Ausín's (2001) analysis: <i>parecer</i> as a modal	192
3.4. Subjunctive Dependents	197
4. A Note on SPEC- <i>v</i> */T _S and Preverbal Subjects	219
5. Residual <i>Object Shift</i> in Romance	229
5.1. VOS in NSLs	236
5.2. A Multiple Agree Analysis for VOS?	256
5.3. VSO in NSLs	269
6. The EPP ₂ : [person] Checking and Doubling	269
7. Conclusions	275

CHAPTER IV: On (Sub-)extraction

1. Introduction.	277
2. Locality Revisited: <i>Cycles, Barriers, and Phases</i>	281
3. Sub-extraction from SPEC- <i>v</i> *.	290
3.1. The <i>Subject Condition</i>	290

3.2. Kuno's (1973) <i>Incomplete Constituent Effects</i>	303
3.3. Sub-extraction from Shifted and Agreeing Objects.	307
4. The C/ACoE and C*P Dependents.	318
5. Some Observations about PPs: Consequences for the Argument/Adjunct Distinction and Prepositional <i>Phase Sliding</i>	323
6. Sub-extraction from SPEC-C*: <i> criterial Freezing</i> and the <i> Minimal Link Condition</i>	335
6.1. Uriagereka's (2004) Analysis.	341
6.2. PP Sub-extraction or "Aboutness" Dependents?	348
6.3. A-bar Systems and the MLC.	355
7. Remaining Issues: the <i> Subject Condition</i> (a reply to Fortuny 2007).	365
8. Conclusions.	379
CHAPTER V: Summary	380
REFERENCES	383

PHASE THEORY AND PARAMETRIC VARIATION

by

Ángel J. Gallego

ABSTRACT

The goal of this dissertation is to explore Chomsky's *Phase Theory* (see Chomsky 2000; 2001; 2004; 2005; 2007; to appear) and its connections with parametric variation. The study considers the hypothesis that syntactic computation operates through small derivational leaps (the *phases*), paying special attention to the Case/agreement systems, and the role of overt morphology for linguistic variation.

Chapter I presents the general guidelines of the framework that shall be assumed throughout the dissertation (the so-called *Minimalist Program*; see Chomsky 1993a through the present), concentrating on both the core computational operations (*Merge* and *Agree*) and the cyclic nature of the system.

Chapter II is devoted to the notion of *phase*, whose identification criteria are considered at length. I adopt Pesetsky & Torrego's (2001) hypothesis that what is normally referred to as 'Case' is actually an uninterpretable 'aspect'/'tense' feature on D heads, and entertain the idea (present in Chomsky's system, as well as in Pesetsky & Torrego's) that uninterpretable morphology can be used for syntactic processes only within a short, phase-based, time span.

In line with Uriagereka (1999b), I further propose that *Null Subject Languages* (NSLs) resort to an additional process of Transfer that is

responsible for a macro-parameter triggered by verb movement, which I call *Phase Sliding*. Plausibly, this mechanism explains the particular status of subjects in NSLs (e.g., subject extraction, *that*-deletion, obligatory inversion, etc.) and additional empirical facts, previously framed in terms of bounding nodes, L-marking, government, or the A/A-bar distinction.

In **chapter III**, attention is shifted to a micro-parameter related to the edge of phase heads (their *Left Periphery*). I argue for a parametric cut that concerns what Uriagereka (1995a; 1995b; 2002b) calls “FP,” a projection related to discourse-oriented semantics (formerly, “surface interpretation”). I claim that the ‘hot’ syntactic activity of Uriagereka’s F is not limited to the CP layer, but is actually found in the v^*P too, in a parallel fashion (actually, as predicted by Uriagereka 2002b, the pattern extends to nominal environments): those languages with a more active CP, have a more active v^*P . I relate this peripheral boost to overt morphology, a traditional idea that is sharpened and connected to tense morphology and head movement.

The second part of the chapter focuses on VOS structures in NSLs, for which I argue that there are two strategies: object scrambling and VP topicalization (see Belletti 2004, Cardinaletti 2001b, and Ordóñez 1997; 1998b). With Ordóñez (1997; 1998b), I take Spanish VOS to be derived through object scrambling, consider its consequences for nominative Case assignment in minimality terms, and eventually revamp an equidistance-based analysis, in the sense of Chomsky (1993a).

Chapter IV is dedicated to (sub-)extraction. I argue that islandhood cannot be entirely accounted for in structural terms (see Chomsky 1986a; 2004; to appear), being better understood if related to freezing effects that emerge from the interaction between Case and agreement (see Boeckx 2003a).

ACKNOWLEDGMENTS

I want to express my gratitude to José M. Brucart and Juan Uriagereka, my advisors, for confiding in me and my work, for helping me writing this dissertation, and, most importantly, for their constant support.

José M. Brucart introduced me in the world of generative grammar years ago (finishing the job started by my high school teacher Sergi Quintana), when I was an undergraduate student. I remember my attending his classes with fascination, and it was thanks to him that I decided to study linguistics. I also thank José María for having supported me during my years at UAB and for having provided me with freedom to pursue my own ideas.

I met Juan Uriagereka in Vitoria in January of 2004. From the first time I talked to him, I was fascinated by his vast knowledge, which goes way beyond Linguistics. Juan's work has inspired mine ever since, and I can barely express how much I have learnt from him. His constant support, his guidance, and his confidence in me and my work provided me with the strength to keep on working in the most difficult moments.

M. Teresa Espinal, M. Lluïsa Hernanz, and Gemma Rigau deserve special gratitude. I thank them for helping me whenever I needed their advice, for caring about me, and for making me improve as a linguist and as a person.

Jaume Mateu has always been a reference for me –I think he is a reference for every student of linguistics at UAB. I thank Jaume for many things: for sharing his knowledge with me, for supporting me, and for his friendship.

I have also learnt from Rebeca Martín and Germán Cánovas. Rebeca has always been a constant academic reference for me, ever since we were classmates –I doubt anyone works as hard as she does; plus, Rebeca is also a reference in terms of honesty, kindness, and friendship (but this will not surprise those who know her). Germán is perhaps the cleverest and funniest person I

have ever met; I was introduced to him at some point in 1998 or 1999, and although at first glance I did not like him, I ended up not only liking him, but in fact admiring him: such is life. I have learnt many things from Germán, and he has helped me so many times that I can't even remember the number.

I am also indebted to the following people, most of them from the *Grup de Gramàtica Teòrica* and the departments of Catalan and Spanish Philology at UAB: Lourdes Aguilar, Santiago Alcoba, Montse Amores, Sergio Balari, Pere Ballart, Anna Bartra, Eulàlia Bonet, José Manuel Blecua, Cristina Buenafuentes, Teresa Cabré, Daniel Casals, Cecilio Garriga, Anna Gavarró, Diana González, Andrés Guerrero, Lourdes Güell, Silvia Jiménez, José Ramón López, Mireia Llinàs, Joaquim Llisterri, Albert Lloret, Anna Llucà, María Machuca, Rafael Marín, Joan Mascaró, Mar Massanell, Carme de la Mota, Silvia Perpiñán, Carme Picallo, Pilar Prieto, Gemma Puigvert, Toni Rivas, Francisco Rico, Yolanda Rodríguez, Juan Carlos Rubio, Carlos Sánchez, Ester Sánchez, Guillermo Serés, Jaume Solà, Jaume Tomàs, Cecilia Trujillo, Xavier Tubau, Guillem Usandizaga, Ramón Valdés, Fernando Valls, and Xavier Villalba.

I also thank Magda Alemany, Maria Corredera, Belén Martínez, Rosa Muñoz, Rosa Pose, Esperanza Ramírez, and, very especially, M. Teresa Ynglès and Mailo Serveto, for their inestimable technical and academic help.

From the *Universitat de Barcelona*, I thank Víctor Acedo, Jordi Fortuny, Txuss Martín, and Joana Rosselló. From the Basque Country, I thank Maia Duguine, Gorka Elordieta, Kepa Erdozia, Urtzi Etxeberria, Jon Franco, Fernando García-Murga, Eider Gutiérrez, Junkal Gutiérrez, Susana Huidobro, Alazne Landa, Nerea Madariaga, Koldo Sainz, Itziar San Martín, and Adam Zawiszewski. Finally, from Madrid, I want to thank Ignacio Bosque, Luis Eguren, Antonio Fábregas, Olga Fernández-Soriano, Irene Gil, Manuel Leonetti, Margarita Márquez, Amaya Mendikoetxea, Norberto Moreno, Isabel Pérez, Juan Romero, Cristina Sánchez, and Soledad Varela.

I am the linguist I am because of Esther Torrego. I attended a course by Esther in the *Instituto Universitario Ortega y Gasset* in 2003 and from that

moment on my perspective on theoretical linguistics changed entirely. I honestly thank Esther for helping me to become a better linguist.

Also for helping me whenever I contacted them by e-mail or in person, I thank Adriana Belletti, Valentina Bianchi, Anna Cardinaletti, Heles Contreras, João Costa, Caterina Donati, Ricardo Etxepare, Kleanthes Ghromann, Liliane Haegeman, Elena Herburger, Wolfram Hinzen, Paula Kempchinsky, Richard Larson, Andrea Moro, Paco Ordóñez, Pascual Masullo, Clemens Mayr, Jairo Nunes, Javier Ormazabal, David Pesetsky, Josep Quer, Ian G. Roberts, Eric Reuland, Marc Richards, Luigi Rizzi, Francesc Roca, Myriam Uribe-Etxebarria, Luis Vicente, Karen Zagona, M. Luisa Zubizarreta, and, very especially, Cedric Boeckx and Noam Chomsky.

Cedric Boeckx cannot be human (he knows too much), and yet his generosity and encouraging support proves me wrong time after time. I want to thank him for his help during the dissertation writing period: he went through the manuscripts every time I asked him for (and more than that, much more), making suggestions of all kinds. There is no doubt to me that this dissertation owes a lot to Cedric's guidance.

I thank Professor Chomsky for always having time to answer my (sometimes exhausting) e-mails and meet at his office, for all his kindness and generosity, and for his stimulating advice: he is a constant source of inspiration.

I cannot forget my stay at the *University of Maryland at College Park*, where I took an important intellectual and personal leap. I particularly want to thank Norbert Hornstein for his help and insightful suggestions on any topic I asked him about during our appointments. I am also indebted to Tonia Bleam, Howard Lasnik, and Paul Pietroski. From the people there, I thank Scott Faults, Chizuru Nakao, Akira Omaki, Hajime Ono, Iván Ortega-Santos, Eri Takahashi, and Heather Taylor. Special thanks go to Tomo Fujii and Masaya Yoshida, from which I learnt a lot, intellectually and personally.

I am not forgetting about Leticia Pablos, it is just that do not know how to thank her for what she did for me. It was because of Leticia that my stay at Washington D.C. was the way it was –she literally saved my life. *Eskerrik asko, Leti.*

I must also mention the names of people I have meet somewhere in conferences, courses, trips, or even by e-mail: Klaus Abels, Roberta D'Alessandro, Karlos Arregi, Adolfo Ausín, Theresa Biberauer, Mario Courbis, Carlos de Cuba, Valérie Gautier, Nicolas Guilliot, Youngmi Jeong, Mélanie Joutteau, Beste Kamali, Masakazu Kuno, Terje Lohndal, Jorge López-Cortina, Guillermo Lorenzo, Luisa Martí, Lanko Marušič, Jon McDonald, Takashi Munakata, Dennis Ott, Phoebos Panagiotidis (and his wife Joana), Omer Preminger, Lara Reglero, Milan Rezac, Bridget Samuels, Serkan Sener, Emma Ticio, and Suleyman Ulutas. I am sure I am forgetting some more.

Before concluding, I want to thank my closest friends and family, who have constantly suffered from my stubborn dedication to linguistics: Javier Aguilar, Mònica Batallé, Santiago Contreras, Ignacio del Cuadro, Ángel Gago, Raquel González, Aritz Irurtzun, Javier Lleida, Julián Maillo, David Martín, Jordi Monsó, Jaime Pardo, Jordi Pina, Iván Sarasa, my parents Manuel and Patricia, my brothers Manuel, María, Pablo, and Rosa, my sister-in-law Sonia, my nephew Manuel, and my niece Sheila.

Finally, and certainly most importantly, I thank Sandra for making this dissertation be the least important thing during the months I spent writing it, for bringing balance to my life, and for many more things language cannot be used to express.

Ángel J. Gallego
Sabadell, December 2007

CHAPTER I

THE FRAMEWORK

1. Introduction

The goal of this chapter is to outline the design characteristics of the framework that shall be assumed in this dissertation, the so-called *Minimalist Program* (MP, from Chomsky 1993a through the present), introducing the specifics of the operations *Merge* and *Agree*, and paying special attention to the hypothesis that syntactic computation operates within defined, cyclic, boundaries.

2. Design Factors and the Strong Thesis

Generative Grammar endorses the hypothesis that language is a component of the human mind/brain: *the Faculty of Language* (henceforth, FL). Ever since Chomsky (1965: 59), generativist investigations have assumed that FL is largely regulated by three factors (for a more explicit formulation, see Chomsky 1975; 1993b; 2005):

(1) FACTORS IN FL DESIGN

- a. Genetic endowment
- b. Experience
- c. Principles not specific to FL

[from Chomsky 2005: 6]

From the *Principles & Parameters* perspective (P&P; Chomsky 1981; 1982; 1986a; 1986b, and Chomsky & Lasnik 1995) attention was mainly devoted to overcoming the tension between factors (1a) and (1b) –between “descriptive” and “explanatory” adequacy. It was soon noticed, for instance, that a rule-centric approach to language was at odds with pretty simple learnability observations, which demanded to focus on factor (1a). In this vein, another important qualification was introduced during the P&P period: the key empirical distinction between *I-Language* and *E-Language* (see Chomsky 1986b) which made it possible to regard FL as an abstract computational capacity, a

generative procedure itself, not a set of “well-formed formulas” –the latter would correspond to a classical conception of language, inherited from logic and similar formal disciplines.

As Chomsky (2005) observes, the P&P framework allowed not only to solve the aforementioned tension, but also settled the scenario to shift inquiry from the first factor to the third one, namely, to “language independent principles of data processing, structural architecture, and computational efficiency” (Chomsky 2005: 9), which is one of the goals pursued by the MP. It must be highlighted, though, that minimalism does not pursue the hypothesis of FL being (maximally) efficient from a methodological perspective (as would be the case in any science), but from an ontological one. If such a possibility is entertained:

We can, in short, try to sharpen the question of what constitutes a principled explanation for properties of languages, and turn to one of the most fundamental questions of the biology of language: *to what extent does language approximate an optimal solution to conditions that it must satisfy to be usable at all, given extralinguistic structural architecture?* These conditions take us back to the traditional characterization of language, since Aristotle at least, as a system that links sound and meaning. In our terms, the expressions generated by a language must satisfy two interface conditions: those imposed by the sensorimotor system SM and by the conceptual-intentional system C-I that enters into the human intellectual capacity and the variety of speech acts. [from Chomsky 2005: 9-10 –emphasis added, AJG]

In Martin & Uriagereka (2000), these options are teased apart by drawing a distinction between *methodological minimalism* and *ontological minimalism*. Methodological Minimalism (alternatively, what Chomsky calls the ‘weak thesis’) is common practice to all sciences and can hardly be disregarded, if only because of its therapeutic value: it gives a name to the search for theories that reduce their technical apparatus without affecting empirical coverage. Notice, therefore, that GB was already methodologically minimalist: the notion of *government* (see Chomsky 1981 and Uriagereka 1988a) aimed at unifying the different submodules of the grammar, and, similarly, the *Barriers* program outlined in Chomsky (1986a) tried to subsume some of Ross’s (1967) and Huang’s (1982) findings.

It is ontological minimalism that really defines the MP as something brand new: we are no longer asking how elegant our theory of FL can be, but rather how elegant *FL itself* is. As Martin & Uriagereka (2000) observe, developments in the methodological

side may (and normally do) lead to progress within the ontological one: this is what happened in the realm of phrase structure, where Chomsky's (1970) pioneering work on *X-bar Theory* (see also Jackendoff 1977 and Stowell 1981) proved more adequate than previous PSG-based accounts, highlighting one fundamental property of natural language phrase structure: endocentricity. Examples of this sort abound, not only with respect to phrase structure: Rizzi's (1990) *Relativized Minimality*, Kayne's (1994) *Linear Correspondence Axiom*, Cinque's (1999) *Adverb Hierarchy*, or Hale & Keyser's (1993) *Lexical-Syntax* project are also minimalist in this very sense. Ontological Minimalism can thus be regarded as a 'strong thesis' about FL design, the expression of the idea that language communicates with external systems of human biology in an optimal way. This is what Chomsky (2000) calls *Strongest Minimalist Thesis*:

(2) STRONGEST MINIMALIST THESIS (SMT)

Language is an optimal solution to legibility conditions

[from Chomsky 2000: 96]

Once (2) is seriously entertained, linguistic inquiry seeks to recast substantive principles from considerations about computational efficiency and properties of the systems with which FL must interact: the *Sensorimotor* (SM) and *Conceptual-Intentional* (C-I) systems. More generally, minimalism seeks to "show that the basic principles of language [can be] formulated in terms of notions drawn from the domain of (virtual) conceptual necessity" (Chomsky 1993a: 171). This turn of attention into the external systems had important consequences for grammar design. Consider (3a) vis-à-vis (3b), in this respect:¹

¹ Access to the *Lexicon* in (3b) shows a double option, depending on whether Lexicon-Syntax communication is direct, or mediated through a *Lexical Array*. See chapter 2.

(3a) *Government & Binding*

(3b) *Minimalist Program*

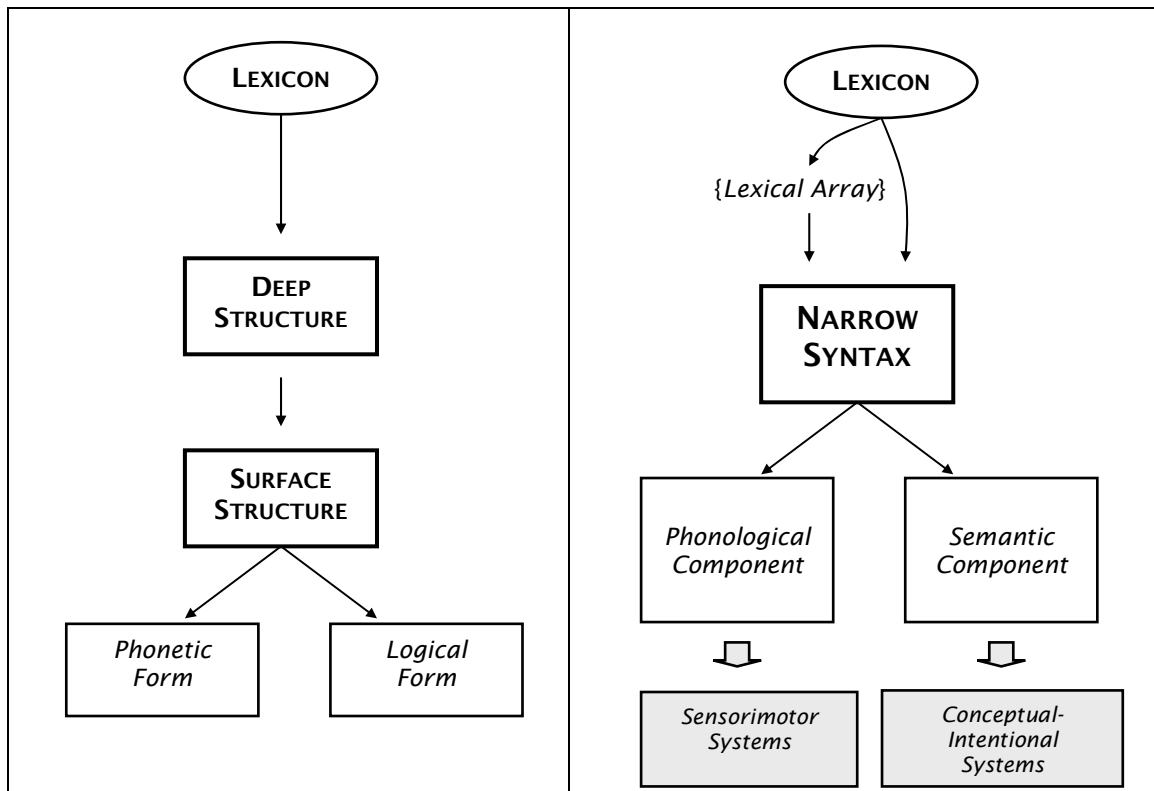

As the reader may easily see, both GB and MP regarded FL as formed by a *Lexicon* and a *Computational System* (i.e., a *Narrow Syntax*). For the time being, let us put Lex to the side (and the important issue of whether it is ‘distributed,’ in Halle & Marantz’s 1993 sense), concentrating instead on *Narrow Syntax*.

The most conspicuous asymmetry between GB and MP concerns the elimination of the three (internal) levels inherited from the so-called “Y-model” of Chomsky & Lasnik (1977): *Deep Structure* (DS), *Surface Structure* (SS), and *Logical Form* (LF). The distinction between DS and SS aimed at capturing the existence of a linguistic level prior to transformational operations where thematic and X-bar relations were established (DS, the ‘base component’), SS being the visible result of different processes manipulating initial configurations (e.g., wh-movement, trace insertion, extraposition, deletion, etc.). Together with DS and SS, LF is further eliminated in Chomsky (2000) as a ‘level of

representation,' and redefined as a 'component' (see Uriagereka forthcoming).² In other words, from Chomsky (2000) onwards, LF ceases to exist as a symbolic system with particular formal properties and operations (QR, expletive replacement, absorption, etc.), surviving merely as a component (a substantive part of the system with no *designated class* of objects associated to).

Consider finally the objects external to the FL itself in (3b): the *Sensorimotor* (SM) and *Conceptual-Intentional* (C-I) systems. As said above, it is minimalism that allows us to take seriously the idea that linguistic phenomena are geared by external requirements of the PHON and SEM components –the *interfaces* between Narrow Syntax and the external systems. Such a possibility not only opens the door for FL to meet general biological restrictions, but also to reconsider whether certain internal properties are still needed. In other words, it opens the door to find out whether such-and-such properties follow from general (i.e., not language specific) principles, and not internal mechanism that appear to have no natural counterpart in the biological world (e.g., government, indices, or lambda abstraction).

Importantly, the SMT reinforces the idea that the external systems have properties of their own, properties which syntax must interact with and ultimately satisfy. Such a perspective seems to be the one Chomsky (2000; 2001; 2004; 2005; to appear) has in mind, and it is consistent with the view that computational operations have a role at the interfaces. In the case of the operation Merge, for instance, Chomsky (to appear) makes the following claim about its relation with the C-I systems:

(4) THE C-I HYPOTHESIS

C-I incorporates a dual semantics, with generalized argument structure as one component, the other one being discourse-related and scopal properties. *Language seeks to satisfy the duality in the optimal way* [see 2], *EM serving one function and IM the other*³ [from Chomsky to appear: 8 –emphasis added, AJG]

² In Chomsky (2000; 2001) covert movement is reinterpreted as instances of a (long-distance) dependency called *Agree* (see section 3.2.), dispensing with Chomsky's (1995b) *Attract*. Chomsky (2004), due in part to Nissenbaum's (2000) and Pesetsky's (2000) findings, assumes covert movement again.

³ EM and IM stand for "external Merge" and "internal Merge," respectively. See section 3.1.

The main goal of the preceding lines was to reflect what the research attitude of minimalism with respect to linguistic inquiry is, with the impact this has for the internal make-up of the grammar (most remarkably, the elimination of *internal* levels inherited from the Y-model). As we have seen, minimalism does not differ from GB in its methodological aims. However, minimalism does not commit itself to a better description of the data –this is not the goal of minimalism, and remains (if it does at all) only as a consequence. What minimalism does pursue is whether linguistic phenomena can be understood by sticking to guidelines of computational efficiency and interface conditions.⁴

3. Computational Operations

In the previous section it was noted that a language L is taken to consist of two main components: Lexicon and Narrow Syntax. Although this is not the place to offer a detailed picture of how the lexicon is conceived within the MP (see Baker 2003, Borer 2005a; 2005b, Hale & Keyser 2002, Halle & Marantz 1993, Harley & Noyer 1999; 2000, Marantz 1997; 2000, among others), a sketch is in order.

The background assumption within minimalism is that FL specifies a set of features available to each particular language L. Let us call this universal repertoire F_{UG} (i.e., features of Universal Grammar). Design factor (1b) makes a selection from F_{UG} to form F_{PG} (i.e., features of a Particular Grammar), which are then assembled into a particular lexicon: a collection of *Lexical Items* (LIs). We then reach the F vs. LI distinction, a non trivial one under the fairly standard idea that only some features become LIs. Take the case of agreement and Case, which cannot arguably be defined as LIs,⁵ although they are (a collection of) features. Let us formalize this as the *Lexicon Assumption*:

⁴ A much more drastic take is being pursued by Wolfram Hinzen (see Hinzen 2006), who denies the existence of the C-I systems and its entities (e.g., proposition, truth, judgment, reference, etc.) by *fiat*, trying to derive them from syntax.

⁵ One comment is in order, for the sake of clarification. Agr (for agreement) and K (for Case) have indeed been analyzed as LIs projecting X-bar configurations (see Chomsky 1991; 1993a and Kayne 1994). As Chomsky (1995b; 2000) puts it, it is “categories lacking interpretable features” that cannot be treated as LIs, so elimination of Agr nodes (at least within the verbal domain) follows. This perspective, however, does not preclude, as far as I can tell, that (purely) interpretive notions such as topic or focus are given a lexical nature, much like in Rizzi’s (1997; 2004; 2006) work.

(5) **LEXICON ASSUMPTION**

Some features from F_{UG} become LIs (categorial ones), others are just assembled within LIs, not being manipulated by the basic computational operation of Merge

(5) provided, the lexicon consists of LIs and features, both of which can be accessed without restrictions. However, structure building operations cannot treat features as they do LIs (*contra* Chomsky's 1995b *Attract*). Hence, Narrow Syntax sees LIs as atomic units with different properties (i.e., features) assembled within:⁶

(6) **PROPERTIES OF LEXICAL ITEMS (LIs)**

- a. Phonological
- b. Semantic
- c. Formal

The list in (6) is in accordance with Chomsky's (1995b) claim that LIs contain information that cannot be derived from independent principles: idiosyncratic properties (i.e., exceptions). This scenario is then closer to *Strong Lexicalism*, and departs from *Distributed Morphology* (DM; see Halle & Marantz 1993, Harley & Noyer 1999; 2000, and Marantz 1997; 2000), a framework which abandons traditional conceptions of the lexicon, exploding the information in (6) in different lists, as depicted in (7):

⁶ See Chomsky (1995b: 230-231, 235-241, 277-279; 2001: 10) for relevant discussion. Since it is not crucial for my concerns, I put aside the *optional* or *intrinsic* distinction (see Chomsky 1995b: 231), as well as the notion of *strenght* of GB and early minimalist formulations (see Chomsky 1991; 1993a; 1995b).

(7) DISTRIBUTED LEXICON

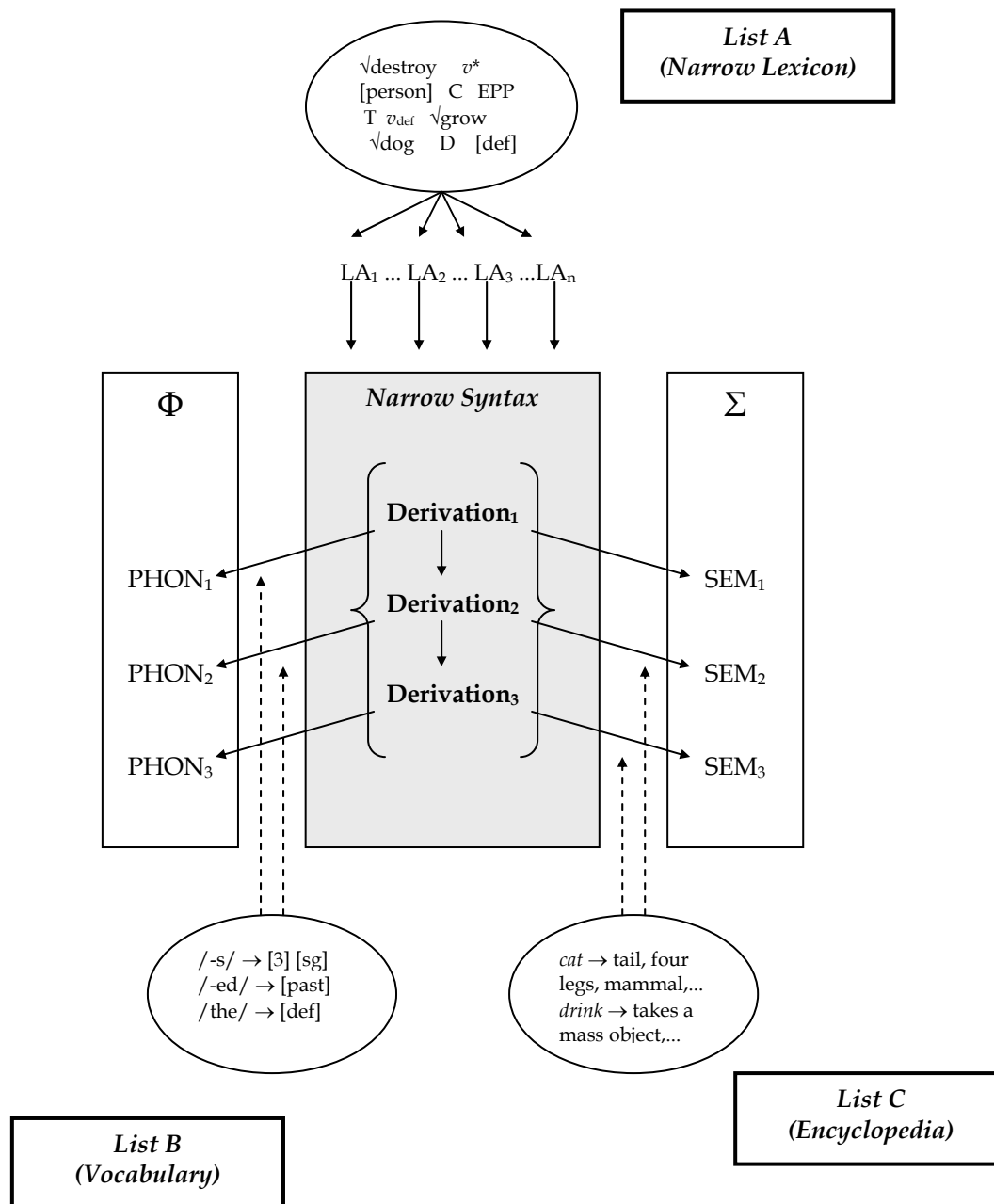

The DM framework suggests that Narrow Syntax makes use of elements from the *List A* alone: abstract morphosyntactic features. This makes sense within a system like Chomsky’s (1995b; 2000; 2001), where only formal features activate syntax: it is not immediately obvious that phonological properties have any bearing during computation (but see Lasnik 2003a’s work on affix hopping), and things become even trickier when it comes to semantic properties (see chapter 2). Along this dissertation, I will make the assumption that syntax only cares about formal features.

Once some basic assumptions about the lexicon have been laid out, let us consider how these interact with the core computational operations Merge and Agree.

3.1. Merge

This section introduces the most fundamental operation within minimalism: set Merge. Firstly, I review how key notions from X-bar Theory (e.g., containment, c-command, etc.) can be derived in bare terms. Secondly, I delve into Chomsky's (2004; 2005; 2007; to appear) idea that Merge comes into two varieties due to interface requirements. Advancing what I will propose in subsequent chapters, I discuss whether the application of Merge is parasitic on "feature sharing" (see Boeckx 2002a, Frampton & Gutman 2000, and Pesetsky & Torrego 2006). Finally, I sketch Chomsky's (2004) analysis of adjuncts as dependents introduced by a version of Merge which creates an asymmetric relation: pair Merge.

3.1.1. Bare X-Bar Theory

Chomsky (1995b; 1995c) puts forward a *Bare Phrase Structure* (BPS hereafter) approach to X-bar Theory,⁷ its main goal being that of minimalism itself: to reduce the properties of FL to conceptual necessities and interface conditions. BPS aims at recasting the core empirical properties of the X-bar schemata of (8)/(9) (e.g., endocentricity, binary branching, the X' vs. X distinction, c-command, etc.) with no other tools than the lexicon and those mechanisms that follow from conceptual necessities.

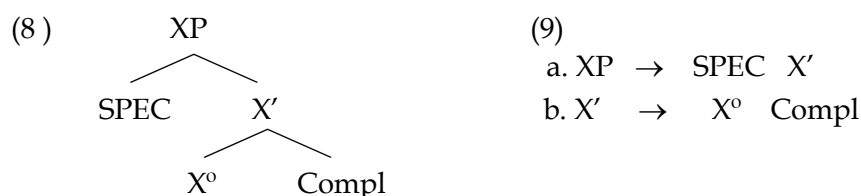

⁷ See Boeckx (2006a), Chametzky (2000; 2003), and Fukui (2001) for ample discussion.

On conceptual grounds, we only need an operation gluing LIs together to create larger units (phrases): Merge. As Chomsky (1995b) puts it, this operation (or any notational variant) is required.

Bearing in mind the discussion of the previous section, let us assume Merge only manipulates LIs, in a non-distributed sense:

(10) **MERGE ASSUMPTION**

Merge only operates with LIs, not features

In Chomsky (1995b), the first formulations of BPS, Merge is taken to build syntactic objects with the form of binary sets, as depicted in (11):

(11) Merge $(\alpha, \beta) = \{\alpha, \beta\}$

Chomsky (1995b) further assumes that (11) has the form of (12), where γ indicates the semantic type or syntactic category of the resulting syntactic object:⁸ the *label*.

(12)

a. Merge $(\alpha, \beta) = \{\gamma, \{\alpha, \beta\}\}$ *bare (official) notation*

b.  *X-bar (informal) notation*

According to Chomsky (2004: 108; to appear: 8), application of Merge yields two fundamental properties; the first one is *set-membership* (\in ; formerly, *containment* or *dominance*) –which, derivatively, provides *term-of*,⁹ defined as in (13):

⁸ I assume that syntactic objects are either: a) LIs or b) phrases (both maximal and non-minimal projections).

⁹ Given that it is not directly relevant for my purposes, I will not consider the technical details of the notion *term* (see Chomsky 1995b: 247). See Uriagereka (1998: *Appendix*) for discussion.

(13) **TERM (formerly, constituent)**

a. K is a term of K. [i.e., the entire set is a term]

b. If K is a term of K, then the members of the members of L are terms of K.

[from Chomsky 1995b: 247]

The second fundamental syntactic relation in Chomsky (to appear: 8) is that of *Probe-Goal*, which will be assessed in detail in section 3.2.

Merger of α and β , then, yields (14) and the relations in (15):¹⁰

(14) Merge (α, β) = $\{\gamma, \{\alpha, \beta\}\}$

(15) *Syntactic relations*

⊠ *set-membership*

$\alpha \in \{\alpha, \beta\}$

$\beta \in \{\alpha, \beta\}$

$\gamma \notin \{\alpha, \beta\}$

$\gamma \in \{\gamma, \{\alpha, \beta\}\}$

⊠ *term-of*

$\{\gamma, \{\alpha, \beta\}\}$ is a *term-of* $\{\gamma, \{\alpha, \beta\}\}$

$\gamma \in \{\gamma, \{\alpha, \beta\}\}$, therefore it is a *term-of* $\{\gamma, \{\alpha, \beta\}\}$

$\{\alpha, \beta\} \in \{\gamma, \{\alpha, \beta\}\}$, therefore it is a *term-of* $\{\gamma, \{\alpha, \beta\}\}$

$\alpha \in \{\alpha, \beta\}$, therefore it is a *term-of* $\{\gamma, \{\alpha, \beta\}\}$

$\beta \in \{\alpha, \beta\}$, therefore it is a *term-of* $\{\gamma, \{\alpha, \beta\}\}$

Building on Epstein's (1999) work, Chomsky (2000) defines c-command as being parasitic on Merge: when α merges with β , α c-commands all the members of β .¹¹ In (16), say, c-command thus establishes a relation between α , β , and δ : those syntactic objects never undergo Merge with each other, but they communicate through c-command regardless.

(16)

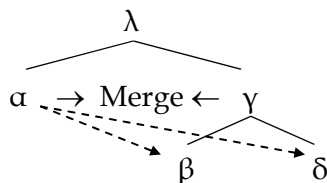

¹⁰ Two relations are left aside on purpose: *sisterhood* and *motherhood* (or, more accurately, the *is a* relation of Chomsky 1955[1975]). The former can unproblematically be recast in terms of set-membership, whereas the latter requires a more detailed comment, as it depends on the ultimate status of labels. See Uriagereka (1998: *Appendix*).

¹¹ Chomsky's (2000: 116) definition of c-command is different, for he resorts to the composition of "sisterhood" and "containment," notions he currently dispenses with.

Epstein's (1999) *derivational* definition of c-command is as follows:¹²

(17) **DERIVATIONAL C-COMMAND**

X c-commands all and only the terms of the category Y with which X was paired by Merge or by Move in the course of the derivation

[from Epstein 1999: 329]

The bare system outlined by Chomsky (1995b) also derives bar-level distinctions: X^0 , X' , and X'' . Since we only have X , a *bare* form (with no subscripts, bars, or indices indicating its status), that information must be retrieved from relational factors. Any LI is then *a priori* both XP (a phrase) and X (a head): if it does not project, it is an XP, otherwise it is an X. All of this conforms to another principle of efficient computation, the *Inclusiveness Condition*:¹³

(18) **INCLUSIVENESS CONDITION**

Any structure formed by the computation is constituted of elements already present in the lexical items selected for N[umeration]; no new objects are added in the course of computation, apart from rearrangements of lexical properties (in particular, no indices, bar levels in the sense of X-bar theory, etc.)

[from Chomsky 1995b: 228]

Together with (18), Chomsky (2005: 11-13; 2007: 5; to appear: 5) considers a second principle of efficient computation: the *No Tampering Condition*, which subsumes Chomsky's (1993a) *Extension Condition (EC)*, the requirement for syntactic operations to 'extend' the phrase marker, yielding cyclicity.^{14 15}

¹² For a similar alternative to derive c-command see Abels (2003: 78 and ff.) and Uriagereka (1998: *Appendix*).

¹³ Throughout this dissertation I will continue to use traditional X-bar notation, just for presentational convenience.

¹⁴ See Uriagereka (1998: 310 and ff.) for identical observations, considering the issue of overwriting.

¹⁵ Both EC and NTC are clear minimalist counterparts of Emond's (1970) *Structure Preserving Hypothesis*: as the derivation goes along, no structure can be changed or destroyed.

(19) NO TAMPERING CONDITION¹⁶

Merge of X and Y leaves the two SOs unchanged [...] Merge cannot break up X or Y, or add new features to them. Merge is invariably “to the edge”

[from Chomsky to appear: 5]

As for X' , the intermediate projection, Kayne (1994) (and Chomsky 1995b, following him on different grounds), eliminates it from the system. This point is not trivial, since we want to preclude that intermediate projections c-command their specifiers, for it would predict a wrong linear order under Kayne’s (1994) LCA.

The specifics of the elimination of X' vary from author to author: Kayne’s (1994: 15-16) LCA, for instance, stipulates that X' stands for a maximal projection in a segment-based view of phrase structure à la May (1985), so, for him, (20a) must be represented as (20b), with the consequence of blurring the specifier/adjunct distinction: ZP is both a specifier and an adjunct in his system.

(20)



If this is so, and if the relevant relations are defined in terms of *categories* and not *segments*, X' projections are “stricken from the record,” as Epstein (1999: 331) puts it. In Chomsky (1995b: 243-244) the argumentation is much less elaborated, for he simply stipulates that XP and X are the relevant entities within the bare system, X' becoming “invisible at the interface and for computation” (see Epstein et al. 1998 for additional observations).

Alternative approaches, like Uriagereka’s (1999a) *Multiple Spell-Out*, overcome this problem by proposing a dynamic transfer every time the derivation reaches a stage in which Merge cannot proceed by applying Merge in a monotonic fashion, giving raise to what Uriagereka (1999a) calls *command unit*.

¹⁶ The notion of tampering was introduced in Chomsky (2000: 137), when discussing possible conflicts between *Local Merge* and the *Extension Condition*.

(21) COMMAND UNIT

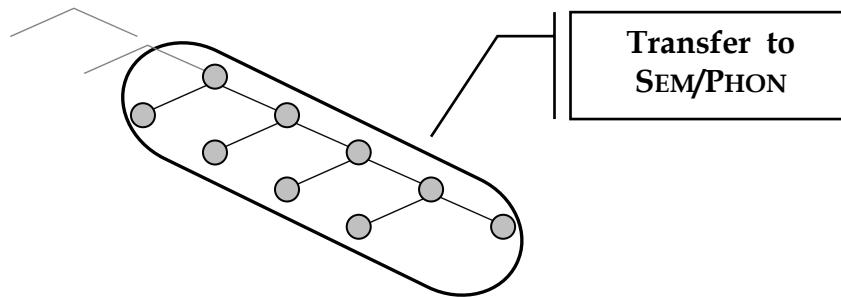

As Uriagereka (1999a) notes, complex specifiers make the system abandon a given command unit in order to build another one, forcing a multiple Transfer/Spell-Out situation where different chunks of structure (command units) are glued together (according to Uriagereka, by means of agreement):

(22) NOT A COMMAND UNIT

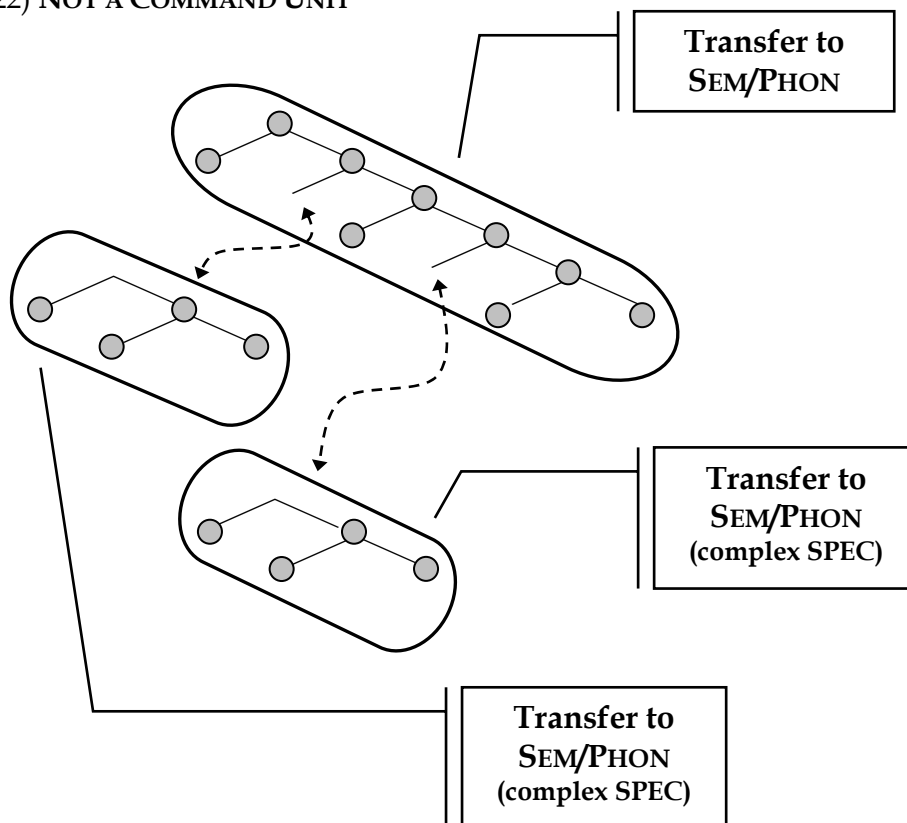

Notice that the problem affecting X' projections crucially relies on the existence of projections –that is, 'labels.' It is therefore relevant to explore this notion in more detail.

3.1.2. Labels and set Merge

Let us start with a simple question: why, according to Chomsky (1995b), does Merge yield (23b) and not (23a)?

(23)

a. Merge $(\alpha, \beta) = \{\alpha, \beta\}$

b. Merge $(\alpha, \beta) = \{\gamma, \{\alpha, \beta\}\}$

Chomsky (1995b: 243) argues that the representation in (23b) is preferred to that in (23a), but only at the (semantic) interface. Simply put: when Merge takes V and D, the output behaves, interface-wise, like V (or D, but not both), an asymmetry that ought to be formally stated somehow. An option to capture this (interface-driven) asymmetry is labeling.

There are grounds to believe that the asymmetry between α and β in (23b) is wanted at both interfaces, since it is there where α and β behave differently: at the SEM-wing, either α or β (say, α) is interpreted as a predicate, whereas the other (β) is interpreted as an argument. As for PHON, α and β differ there as well, for either α linearly precedes β , or vice-versa. Hence, this view claims that the asymmetry of labeling emerges at the interfaces, and at the interfaces alone. The most tendentious interpretation of this thesis can be expressed as (24):¹⁷

(24) **THE RADICAL INTERFACE THESIS**

PHON and SEM properties of syntactic objects (i.e., linear order and semantics) are not computationally relevant, but side-effect (emergent) consequences

Consider the impact of (24) within the realm of theta-theory.¹⁸ Suppose two LIs undergo first-Merge, as indicated in (25):

¹⁷ As Juan Uriagereka observes through personal communication, the fact that both interfaces care about labeling suggests this mechanism is not, in fact, interface-driven, but a deep property of derivational dynamics.

¹⁸ I come back to the role of labels for linearization business in chapter 4. See Irurtzung (in progress) and Lohndal (2006) for discussion.

(25) Merge (love, Mary) = {love, Mary}

As the output of (25) stands, the system sees no difference between *love* and *Mary*. In order to create a difference (in order to formalize that *love* selects *Mary*, and not the other way around), further mechanisms must be introduced. Different devices come to mind, but labeling can do while sticking to inclusiveness:

(26) Merge (love, Mary) = {love, {love, Mary}}

Under (26), the desired asymmetry between *love* and *Mary* now comes to the fore: the former is duplicated by the label –‘projected,’ in X-bar terminology.

Previous work within generative models (see Chomsky 1981 for discussion) assumed that the DP *Mary* received the theta-role of /Theme/, a process which can be conceived of as *love* assigning the feature /Theme/ to *Mary*. This view is problematic in different respects, though. For one thing, it defends that semantic formatives like /Theme/ or /Goal/ are features, but, as far as I know, no morphological evidence supports this view, there being no dedicated morphemes which mechanically relate to ‘being-a-/Theme/’ or a ‘being-a-/Goal/’ (see Boeckx 2006a for a different view, building on data from Rackowski & Richards 2005). But more importantly, as Hale & Keyser (1993) emphasized, such a view is redundant if the system can piggy-back on the (unambiguous) configuration created by phrase structure: if configurations can be used by SEM in such a way that the relational notion of /Theme/ obtains (however this happens, not a trivial matter), then no extra machinery would be required, including notions such as “selection,” “saturation,” “theta-feature assignment,” etc.

The conclusion is apparently compatible with neo-Davidsonian formulations (see Pietroski 2000; 2005), where merger of *arrive* and *Mary* does not yield something like (27a), but (27b) instead:

(27)

a. $\exists e$ [arrive (e) & Mary (e)]

there is an event e such that it was an arriving and it was Mary

b. $\exists e$ [arrive (e) & Theme (Mary, e)]

there is an event e such that it is an arriving and Mary is a Theme of e

The neo-Davidsonian semantics we want is certainly closer to what (27b) says, and labeling can be invoked to obtain that result: we want that merger of *arrive* and *Mary* to yield a relation which was not there in the first place, as Pietroski (2000; 2005) claims.

Consider an extension of the same logic:

(28)

a. Charlie Mingus, John particularly liked.

b. CHARLIE MINGUS John particularly liked!

It is common practice to analyze the expressions in (28) as the result of a checking of sorts (see chapter 2 for additional discussion). Under standard assumptions, the object DP *Charlie Mingus* is supposed to bear a pseudo-semantic feature which has to be checked off against the specifier position of dedicated projections in the CP layer – Rizzi’s (1997; 2004; 2006) *Left Periphery*. For concreteness, let us concentrate on (28a), a case of topicalization. Under the view just described, the moved DP is endowed with a [topic] feature which requires it to be placed in a particular SPEC-H configuration, where a *criterion* is met.¹⁹

In a streamlined system like Chomsky’s (2000; 2001; 2004; to appear), where only formal features undergo *checking* (more to the point, *valuation*) processes, such a teleological implementation lacks conceptual motivation. Chomsky (to appear: 18), in particular, reasonably argues that DPs need no extra mark to receive the peripheral interpretation they get: “that seems superfluous even if feasible, particularly if we

¹⁹ We can define a *criterion* as a representational device which assigns interpretive (i.e., discourse oriented) properties such as focus, topic, and the like to SPEC-H configurations. Note, importantly, that a criterion is not an interface condition for Rizzi (even though it clearly has an impact on the SEM interface), but an internal constraint, analogous to those of the GB framework. See Rizzi (1996; 1997; 2004; 2006).

adopt Rizzi’s approach to the *Left Periphery*: what is raised is identified as a topic by the final position it reaches, and any extra specification is redundant.”

The situation is analogous to that of the theta-system: just like we do not need to posit a semantic formative like /Theme/ when *love* and *Mary* undergo Merge, we do not need to posit it either in the case of discourse-related operations, all that matters being the created configuration, assuming the system has a way to associate base and non-base configurations to theta and discourse oriented notions respectively. In recent writings, Chomsky has suggested that theta and peripheral interpretations appear to correspond, cross-linguistically, to the operations of Merge and Move. Actually, Chomsky (2004) argues that Move is merely another type of Merge: internal Merge. Chomsky (2004), building on intuitions that go back to the 70s (see Culicover 1970 and Jackendoff 1969), distinguishes two varieties of Merge on the basis of a semantic duality at the SEM interface:

(29)

a. *External Merge (EM)*

Merge (α , β) $\alpha \neq \beta$

b. *Internal Merge (IM)*

Merge (α , β) $\neg (\alpha \neq \beta)$

External Merge joins two independent syntactic objects (α and β), taken from the lexicon (or not, if the process invokes a *generalized transformation*; see Chomsky 1993a). In the case of internal Merge, on the other hand, one of the syntactic objects is taken from within the other one: α is already present in β prior to its merger. Ever since Chomsky (1993a), it is assumed that internal Merge leaves not a trace, but a copy of the moved element –the gist of the so-called *Copy Theory of Movement*.²⁰ A non-trivial chain is then defined as a set of *occurrences* (see Chomsky 2000: 114-115; 2001: 39), that is, as different instances of a lexical token defined by their context.

²⁰ The notion of “copy,” as understood in Chomsky (1993a), goes back to Chomsky (1955 [1975]). The idea of having unstructured traces was put forward in Fiengo (1977). Technically, the difference is important when it comes to phenomena like reconstruction and linearization. See Boeckx (2001), Fox (2000), and Lasnik (1999c) for discussion about copies, traces, and reconstruction.

To recap so far: we have seen that there is reason for labeling to arise at the interfaces. The important question, then, is whether labeling is needed during computation as well. In this work I will argue it is, for efficient computation reasons: having labels is an optimal way to encode all the relevant information of a complex syntactic object in a non-scattered fashion. Derivations can thus unfold treating complex syntactic objects (phrases) ‘as if’ they were atoms for computation (in the sense of Hornstein 2005).

At present there is no consensus as to whether BPS must make use of labels or not (see Boeckx 2002a; 2006a for discussion).²¹ Suppose it must. Then the question we face, technically, is how these emerge. Chomsky (1995b: 244) considers the most basic set-theory relations: *intersection*, *union*, and *identity*.²²

(30) The label of $\{\alpha, \beta\}$ is. . .

- a. The intersection of α and β (i.e., $\alpha \cap \beta$)
- b. The union of α and β (i.e., $\alpha \cup \beta$)
- c. One or the other of α, β

Due to his tacitly assuming a decompositional approach to syntactic categories in terms of $[\pm N]$ $[\pm V]$ features (see Chomsky 1970; 1981), Chomsky (1995b) rejects both (30a) and (30b), taking (30c) as the correct outcome. In any event, note that all the options in (30) are strongly compositional in one sense or another, for no information is ever lost –the question is what the relevant information ‘percolating up’ turns out to be. In chapter 2, I will follow Boeckx (2002a) in arguing that there is something to intersection about Merge, but I will basically keep the idea that, except for cases of head movement, labels correspond to one of the two syntactic objects.

Let me return to the reduction of bar levels at this point (see previous section). As was said, any LI is *a priori* both XP (a phrase) and X (a head). Note that there is a catch in this deduction, one which is perfectly consistent with the internal necessity of labels:

²¹ Uriagereka (1998: *Appendix*) is the first BSP-based account in which the possibility that SOs be label-free is considered. See also Moro (2000), who provides empirical evidence that a variety of Small Clauses (*Bare Small Clauses*) do not project label. The same basic idea has been applied to adjuncts by Chametzky (2000), Hornstein et al. (2005), and Uriagereka (2003), as we will see in chapter 4.

²² See Citko (2006) for additional discussion about how labels project.

for the system to be able to make these distinctions, labels are needed. In graphic terms, we cannot know whether β is an LI or an XP in (31) if no label obtains:

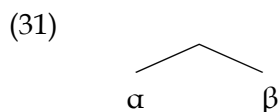

BPS can also capture the notions of *complement* and *specifier* by derivational means. In particular, one could follow Chomsky (2004; 2005; 2007; to appear) in that first external Merge creates the relation *head-complement*, while further external Merge/internal Merge the (potentially unbounded) relation *head-specifier*. But notice that first external Merge just provides a head-to-head relation: the head-to-complement one crucially depends on the asymmetry labeling yields, as indicated in (32):



Subsequent merger of, say, δ provides what is known as specifier. Notice, yet again, that for δ to become a specifier, α must have projected (in other words, δ must find some syntactic object to merge with), or else δ would not even be a dependent.

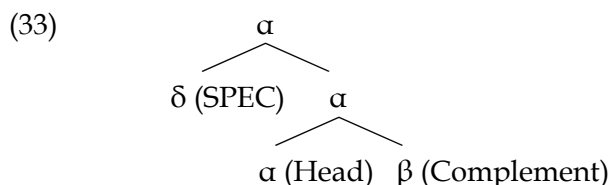

So defined, notions like complement and specifier can be read off from configurations, without further devices. It is important to underscore that these two notions are not substantively different from this perspective: they are essentially the same, as in both cases there is a dependency between a syntactic object (β or δ in the case at hand) and a head (α). We call head-complement the first dependency so established, and head-specifier the subsequent ones. This is clear the minute a bare representation is assumed, as Cedric Boeckx (p.c.) points out to me. In (34) it is clear that both β and δ merge with X:

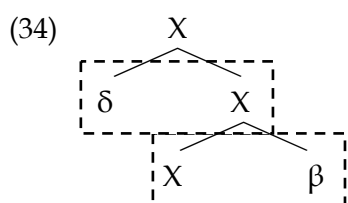

One more time, (34) appears to support that, configuration-wise, complements and specifiers are the same class of entities. This conforms to the idea that dependencies established between specifiers/complements and heads are identical: head-to-head ones.

(35) Apparent SPEC-H relations are in reality H-H relations

[from Chomsky 2004: 113]

Trying to stick to (35), it must be the case that every specifier relates to a head, but this, strictly speaking, is not what one gets in (36): there δ relates not to α , but to its ‘projection,’ as highlighted in (36):²³

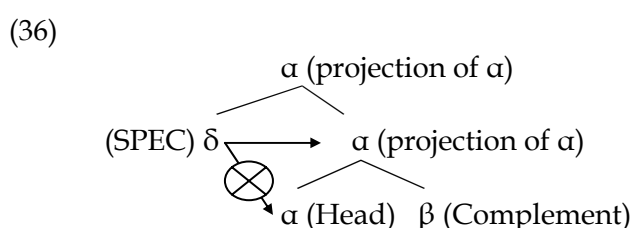

With (36) in mind, and provided labels stand for ‘extended heads,’²⁴ (35) can be refined as (37):

(37) All syntactic relations (i.e., H-Compl and SPEC-H) are H-H relations

But even though (37) is a conclusion worth exploring, one might be skeptical about it: the literature is replete about odd properties of specifiers, not complements (see Cinque 1999, Kayne 1994, Richards 1997, Uriagereka 1999a, 1999b, Koopman 2000, and references therein). Actually, there is one other property about specifiers not shared by

²³ Actually, this conclusion is forced upon us if we want to dispense with m-command, a loose version of c-command which allows heads to relate to their specifiers.

²⁴ See Gallego (2006d) for an analysis of labeling in terms of head movement. The same idea was independently argued for in Aritz Irurtzun’s own work.

complements: while there is one complement per projection, specifiers are potentially unbounded.²⁵ In papers previous to Chomsky (to appear), this asymmetry was even more perspicuous, since specifiers were created by the so-called EPP feature, which, as Boeckx (2002a; 2003b; 2006a) and Lasnik (1999a; 1999b) have extensively argued, is not a feature, but a ‘specifier requirement’ (see chapter 2).

Labels, furthermore, embody the notion of ‘constituent’ and are therefore essential for structure building processes.²⁶ Thus, as Boeckx (2002a) notes, it is difficult to see how syntactic processes like VP topicalization, wh-movement, or VP ellipsis could take place if creation of labels is not allowed, for these operations need to locate the relevant maximal/XP chunks that are targeted.

(38)

- a. [CP [VP Kiss Mary]_i, John did t_i]
- b. [CP [DP Which book]_i did John say Mary read t_i]?
- c. John_z [v*P t_z [VP called Peter]], and Mary did [v*P Susan_i [VP ~~call~~ t_i]]

Virtually, then, any operation targeting XPs needs to invoke labels, and the logic extends to agreement dependencies if ϕ -features are encoded in labels, as explicitly assumed in HPSG approaches to phrase structure (see Sag & Wasow 1999 and references therein):²⁷

(39)

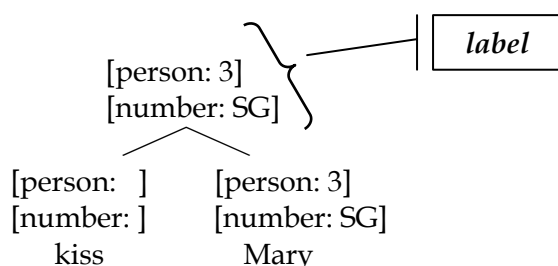

²⁵ This is not a problem for unambiguous projections in Hale & Keyser’s (2002) sense: it just entails that multiple specifiers may yield a non-convergent derivation because they will not receive an interpretation. See chapter 4.

²⁶ I disregard here any technical distinction between nodes and labels. See Chametzky (2000).

²⁷ See Chomsky (1995b: 268), where features are regarded as *sub-labels*.

3.1.3. Adjuncts and pair Merge

The last section was devoted to the operation Merge and –according to Chomsky– its symmetric nature: Merge (α , β) yields the set $\{\alpha, \beta\}$. Arguments were provided to defend the view that, despite its symmetric nature, an asymmetry must also arise, both during the computation and at the interfaces.

It was further noted that reliance of Merge derives the relational notions of *head*, *complement*, and *specifier*. Importantly, nothing was said about the trickiest X-bar type of dependency, namely *adjuncts*. In this section I briefly lay out Chomsky’s (2004) analysis of adjuncts.

Right from the beginning, one key distinction is in order, that teasing apart *adjunct* from *adjunction*. In Chametzky’s (2000) words:

The central conceptual difference between the two is that “*adjunction*” names a syntactic process, a particular form of PM [phrase marker] construction or augmentation, while “*Adjunct*” names a phenomenon, a particular dependency relation. It is clear, then, that the former concept is a theory internal one, while the latter is not: so, for example, a pure dependency theory would, obviously, have no process of “*adjunction*” while it would, equally obviously, make use of the concept, and have some analysis, of “*Adjuncts*” [...] *The question facing MP, and any minimalist theory, then is whether the analysis of the phenomenon requires the use of the process.* If so, then, apparently, the conclusion is established that “*adjuncts*” are not part of the core computational component. If not, then their syntactic status remains open [...] Assimilation of “*Adjuncts*” to “*adjunction*”, then, is neither immediate nor obviously correct. If it is done, a new syntactic kind is on view, one that crosscuts the pre-theoretic taxonomy in terms of functions and phenomena.

[from Chametzky 2000: 143-144 –emphasis added, AJG]

Despite the fact that what is loosely called adjunct does not always need to invoke the X-bar dependency of adjunction (see Hornstein et al. 2005, Uriagereka 2003; 2005; forthcoming, and references therein), it is true that Chomsky’s (2004) analysis does not capture the difference: adjuncts are generated by adjunction, a problem that was inherited from pre-minimalist formulations (most remarkably, that by May 1985). The basic aspect of those analyses of adjunction relied on May’s (1985) *segmented categories*:

(40)

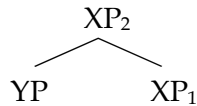

In (40) YP is adjoined to XP. As can be seen, adjunction splits the XP category into two *segments* (XP₁ and XP₂), the hallmark of May’s (1985) formulation. As noted by Abels (2003: 38 and ff.), (40) is worrisome because it forces us to assume not only a relation of dominance, but also a second, *Barriers*-designed, type of dominance. Let us call them, following Abels (2003), *dominance* and *dominance_{Barriers}*.²⁸

(41) **DOMINANCE**

A node N dominates a syntactic object α if N contains α

(42) **DOMINANCE_{BARRIERS}**

A category N dominates a syntactic object α if all the nodes of N (all its *segments*) contain α

Given the definition in (42), YP is ‘trapped’ within XP in (43a) but not in (43b), since only in the former do all the segments of XP contain YP.

(43)

a. *Barrier for YP*

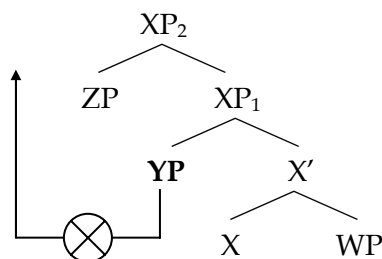

b. *No Barrier for YP*

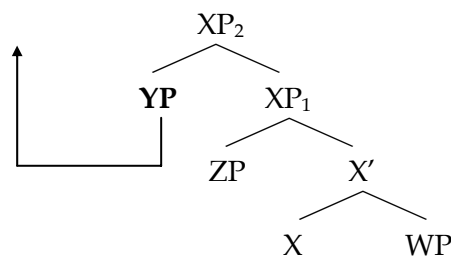

Dominance, as formulated in (42), is therefore designed to place the adjunct in a parallel dimension: by exploiting the category vs. segment category cut, adjuncts are immune to almost all the relevant structural relations one can think of (e.g., dominance, c-command, etc.). In Chomsky (2004) this parallel plane idea is explicitly

²⁸ Recall that within the current system *dominance* is understood as *set-membership*. I use the term *dominance* because I am reproducing Abels’s (2003) argumentation.

assumed (see also Uriagereka 2003), and a new operation to handle it is invoked: pair Merge (PM). As noted by many scholars (see Chametzky 2000, Boeckx 2003a; 2003c, 2006a, Ernst 2002, Uriagereka 2003), Chomsky's (2004) words suggest that adjuncts have no syntax. This is surely consistent with most defining properties of adjuncts (e.g., they do not receive theta-roles, do not check Case, are islands, pose linearization problems, etc.) and with Chomsky's (2004) conceptual speculation that adjunction exists due to requirements imposed by the C-I systems –it is telling enough in fact to remember that Chomsky (1995b: 325) claimed that adjuncts do not fit in the minimalist picture, for they do not seem to participate in any computational operation, an adjunction configuration being neither a thematic nor a checking one.²⁹

The three syntactic operations we have reviewed so far correspond to three different types of semantics, in accordance to the SMT:

(44)

- a. External Merge: argument structure (formerly, deep interpretation)
- b. Internal Merge: discourse-oriented properties (formerly, surface interpretation)
- c. Pair Merge: predicate composition

Under BPS, adjunction is formalized by means of ordered pairs, as that is the only way to code an asymmetry within set theory.

(45)

- a. $\{\alpha, \beta\} = \{\beta, \alpha\}$
- b. $\langle \alpha, \beta \rangle \neq \langle \beta, \alpha \rangle$

A crucial trait of Chomsky's (2004) pair Merge analysis is then the idea that adjuncts involve a more complex structure: $\langle \alpha, \beta \rangle$ not being $\{\alpha, \beta\}$, but rather $\{\{\alpha\}, \{\alpha, \beta\}\}$. This view has recently been questioned, among others, by Paul Pietroski and Wolfram Hinzen (see Hinzen 2006 and Pietroski 2005), who argue, from similar perspectives, that adjunction displays simpler dependencies than argument taking:

²⁹ A *checking configuration* should be understood as a SPEC-H one (see Chomsky 1995b; 2000). See next section.

Prior to all of these layers of structural-semantic complexity [argument structure and binary quantification], however, is a more primitive or archaic one, where there is not even such a thing as arguments bearing thematic roles: the *adjunct system*. Adjuncts are things that are ‘not needed.’ While this is a sad statement to make about adjuncts, it captures their essence. *Any lexical verb has a number of arguments, and it needs each and every one of them. This argument system is extremely limited in human languages. Virtually no verb with more than three arguments exists in any language, with most lexical verbs having only one or two. Again, we wish to rationally design this feature, and it seems likely that the reason is an internalist, not a semantic one: limitations on argument structure fall out from limitations on syntax, if Hale & Keyser (2002) are right. If this is the case, syntactic constraints explain how our concepts, or at least those we lexicalize, are constrained. Correlatively, it is interesting to note that while a verb does not need to have any of its adjuncts (does not select them and assign no thematic roles to them), it may have an infinite number of them: Jill killed Bill with great satisfaction, with her bare hands, at dawn, looking down on him, with contempt (...). This asymmetry seems crucial, and an initial reason for not assimilating arguments and adjuncts, whose syntax indeed is entirely different. Adjunction, as an operation more primitive than argument-taking, does not require the apparatus of hierarchical syntax as given through projection, and perhaps has no significant syntax at all.* [from Hizen 2006: 177 –emphasis added, AJG]

On semantic grounds, Hizen (2006) is right in saying that argument-taking is more complex than adjunction: only arguments need to resort to the notion of theta-role in order to type shift the status of DPs (see Irurtzun in progress). Adjuncts, as (46) shows, are simple predicates of the event (Davidson’s 1967 original insight):

(46)

a. Urtzi read LGB on Saturday.

b. $\exists e$ [read (e) & Agent (Urtzi, e) & Theme (LGB, e) & on-Saturday (e)]

In (46), the clustered adjunct *on-Saturday* is a direct predicate of the event, the syntactic objects *Urtzi* and *LGB* (the arguments) needing the semantic formatives /Agent/ and /Theme/ (the theta-roles) in order to relate to the event. Hence, it makes sense to say that these formatives change the nature of *Urtzi* and *LGB*: they stop being simple DPs, becoming predicative entities, a step I indirectly related to labeling in section 3.1. (see Pietroski 2000; 2005).³⁰

³⁰ A more elaborated neo-Davidsonian analysis of adjuncts is developed by Larson & Segal (1995: 478 and ff.), who point out that both (i) and (ii) should be replaced by (iii):

- (i) $\exists e$ [stab (e) & Agent (Brutus, e) & Theme (Caesar, e) & **with-a-knife (e)**]
- (ii) $\exists e$ [stab (e) & Agent (Brutus, e) & Theme (Caesar, e) & **with (a knife, e)**]
- (iii) $\exists e$ [stab (e) & Agent (Brutus, e) & Theme (Caesar, e) & **Instrumental (a knife, e)**]

One ontologically dubious aspect of Chomsky's (2004) account is that it forces us to postulate an independent operation: pair Merge.³¹ This is in accord with the SMT, but it is not a logical necessity: if semantics piggy-backs on syntax, all we need to capture the different semantics of predicate composition is for its syntax to be different from that of argument-taking, and this does not need a new operation. If possible, then, adjunction should resort to set Merge, the aforementioned asymmetry being a consequence of the lack of label (see Boeckx 2006a, Chametzky 2000, Hornstein et al. 2005, and Uriagereka 2003; 2005; forthcoming). Actually, Chomsky's (2004: 117) formulation does not seem to be far from this: "An adjunction construction is plainly *not the projection of a head*: for NP-adjuncts, for example, the constituent structure appears to be something like [NP XP]" (emphasis added -AJG).

This possibility takes us back to Chomsky's (to appear) speculations about unstable structures, which, interestingly enough, are compatible with what we see in any adjunction configuration within the v^*P : it is always the case that an XP (the adjunct) adjoins to YP, the VP (or v^*P , a matter to be sharpened in chapter 4). The structure would therefore be something like [VP, XP] (by parity of reasoning with the nominal case pointed out by Chomsky 2004), so, formally, the whole structure would behave as a VP because the category which receives adjunction "retains all its properties."

Such an approach is reinforced by the data in (47), where adding adjuncts does not modify the category/type of the syntactic object that is modified. As noted by Hornstein et al. (2005), given that perfective *have* subcategorizes for a perfective *-en* marked V, adding adjuncts like *quickly* or *in the yard* does not change its selectional requirements:

³¹ The asymmetric operation of pair Merge was first introduced in Chomsky (2000). It is important to mention this, because although adjuncts were also said to be asymmetric in Chomsky (1995b: 249), the asymmetry was not expressed by means of a new operation, but by means of the label, which was as in (ii):

- | | | |
|------|---|--------------|
| (i) | $\{\alpha, \{\alpha, \beta\}\}$ | Substitution |
| (ii) | $\{\langle\alpha, \alpha\rangle, \{\alpha, \beta\}\}$ | Adjunction |

The notation of (ii) is replaced by (iii) in Chomsky (2000):

- | | |
|-------|-------------------------------|
| (iii) | $\langle\alpha, \beta\rangle$ |
|-------|-------------------------------|

(47)

a. {Has/*is} [_{VP} eaten a bagel]

b. {Has/*is} [_{VP} [_{VP} [_{VP} eaten a bagel] quickly] in the yard]

Assuming so, let us reformulate Chomsky’s (2004) analysis as in (48), denying the existence of pair Merge:

(48) **MERGER OF ADJUNCTS (non-final version)**

Applied to adjunction (vis-à-vis argument-taking), Merge yields no label

Given the previous discussion about May’s (1985) proposal, it is important to point out that, in bare terms, the segment vs. category distinction cannot be captured: that would require stipulating that ‘third external Merge’ introduces an adjunct, while ‘second external Merge’ a specifier. That is to say, what May (1985) and Chomsky (1986a) analyzed as an adjunct is now a second (third, fourth, fifth, etc.) specifier. The distinction was sound (and, to begin with, implementable) with X-bar machinery, because phrase markers were (generally) restricted to one specifier, but the motivation vanishes with the availability of multiple specifiers. This can be seen in (49):

(49)

a. *X-bar Theory*

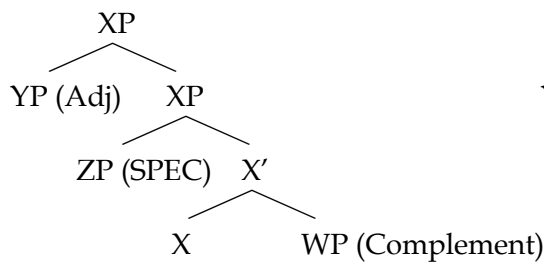

b. *Bare Theory*

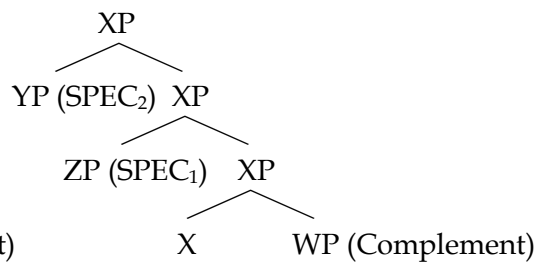

That is to say, given that BPS cannot differentiate XP from X’ (even configurationally, it cannot; see above), there is no way to capture the segment based analysis of adjunction. Under BPS, where only the X^{min} vs. X^{non-min} cut is (configurationally) possible, “unambiguous phrase structure” is restricted to the schemata in (50), an original insight, expressed in featural terms, by Muysken (1982):

(50)

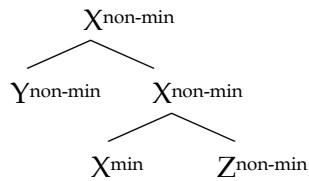

So, from a relational/configurational point of view, X' and XP could be redefined as follows:

(51)

- a. $X' =$ the result of Merge ($X^{min}, Z^{non-min}$)
- b. $XP =$ the result of Merge ($X^{non-min}, Y^{non-min}$)

Crucially, subsequent applications of external Merge would be additional instantiations of (51b), so the result would be, once again, XP , just like what we have in multiple SPEC structures, which, under Hale-Keyser's system, are ambiguous. This way, only two dependents (complement and first-specifier) are possible in a non-ambiguous way. Any other application of Merge is in principle possible, but will yield no configurational gain (it would be 'vacuous,' and presumably barred by *Last Resort*).

In sum, there are only two ways to capture the adjunct dependency (not the operation of adjunction): a) by pair Merge and b) by having unlabeled specifiers. Since I have claimed that the introduction of an additional operation (pair Merge) is not conceptually forced, I will follow the second route, which is as depicted in (52):

(52)

WP = Specifier

ZP = Complement

YP = Adjunct

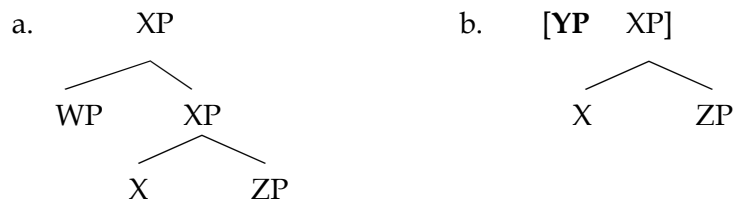

3.2. Agree

So far, this chapter has extensively focused on the basic structure building operation of minimalism: Merge. Special attention was paid to the existence of labels and an operation creating ordered pairs, pair Merge. For reasons already discussed, I have assumed the former, and rejected the latter –if what precedes this section is correct, pair Merge is just a variety of set Merge (external Merge) with no labeling ensuing. Now I want to explore aspects of a second operation, one which does not care about structure building, but rather feature checking: Chomsky's (2000; 2001) *Agree*.

Through the P&P approach various mechanisms were put forward in order to capture the idea that some abstract features (most remarkably, Case) must be checked. In late GB and early minimalist formulations (see Chomsky 1991; 1993a; 1995b), feature checking was thought of as complementing *Theta Theory*. In particular, argument chains (so-called A-chains)³² were taken to have one theta position and one Case position –typically, the first and last links of a non-trivial A-chain; see Chomsky 1995b: 312-316, and Chomsky & Lasnik 1995: 46, 116, 122-124. This assumption about A-chains became to be known as the *Chain Condition* (see Rizzi 1986a and McGinnis 2004 for recent discussion)

(53) CHAIN CONDITION

An A-chain must be headed by a Case position and must terminate in a θ -position

[from Chomsky & Lasnik 1995: 46]

³² There is a vast literature distinguishing between *A-positions* and *A-bar-positions* (see Chomsky & Lasnik 1995: 63). The cut was first related to theta positions (roughly put, A-positions were dedicated to arguments –'A' from 'argumental,' hence the name). This was pretty clear before the advent of the *VP-Internal Subject Hypothesis*, since subjects were directly generated in SPEC-T (SPEC-IP, see Chomsky 1981).

Later on, the definition had to be modified, since subjects in SPEC-T also showed A properties, like binding and control. The way out was to relate theta-role assignment to Case through the notion of 'visibility' (see Chomsky 1986b): a DP was said to be 'visible' to get a theta-role if its Case had been checked. Case, then, came to be viewed as another factor to decide whether a position was A or A-bar.

As Uribe-Etxebarria (1992) notes, the problem with this is that some languages do not need to move subject DPs to SPEC-T to get their Case checked. In those languages, therefore, SPEC-T would be an A-bar position. I come back to the A/A-bar distinction in more detail in chapter 2.

Much effort (particularly, Luigi Rizzi's pioneering work and subsequent developments; see Rizzi 1986a; 1990; 1996; 1997; 2004; 2006) was devoted to show that non-theta checking has a canonical and immutable structural nature, created by internal Merge: SPEC-H configurations.

Kayne's (1989) findings about agreement provided another powerful argument for treating agreement as a relation which was parasitic on SPEC-H configurations, as Boeckx (2004) points out. The paradigm in (54)-(55), from French, constitutes Kayne's (1989) main endorsement. Notice that (54) and (55) differ just in one respect: whether the object DP *la fille* (Eng. *the girl*) moves or not.

(54) Jean a vu(*-e) la fille. (French)
 Jean have-3.SG seen-(FEM.SG) the-FEM.SG girl-FEM.SG
 'Jean has seen the girl'

[from Boeckx 2004: 23]

(55)
 a. Jean l'a vu-e. (French)
 Jean CL-her-have-3.SG seen-FEM.SG
 'Jean saw her'

b. Quelle fille Jean a(-t-il) vu-e. (French)
 which-FEM.SG girl-FEM.SG Jean have-3.SG-he seen-FEM.SG
 'Which girl did Jean see?'

c. Cette fille a été vu-e. (French)
 this-FEM.SG girl-FEM.SG have-3.SG been seen-FEM.SG
 'This girl was seen'

[from Boeckx 2004: 23]

As the data in (55) indicate, the past participle shows object agreement whenever the object DP moves –plausibly, in a successively cyclic fashion– from specifier to specifier (see below): as soon as the relevant specifier is hit (that of the past participle, by assumption), agreement arises.

It was soon noticed, though, that some varieties of checking did not appear to need displacement, an unproblematic situation the minute a covert component was available –that was, say, how accusative Case was assigned in English: by moving object DPs to the specifier position of Agr_OP in the covert component (see Boeckx 2003b; 2006b, Chomsky 1991; 1993a, Lasnik 1999a; 2003a, and Raposo & Uriagereka 1990).

The core idea is illustrated in (56), which represents the early minimalist idea that checking operations involve dedicated domains: so-called “checking domains.”

(56)

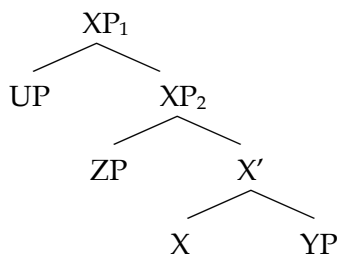

⊗ Relevant notions

Complement domain = YP

Residue = UP, ZP, and X

[adapted from Chomsky 1993a: 177]

In order to refute a purely SPEC-H based approach to feature checking, one must find cases where agreement is overt and no SPEC-H configuration is at stake. As Boeckx (2004) argues, existential constructions in Icelandic and English fit with that description:

(57) There {*seems/seem} to be two men in the boat.

[from Boeckx 2004: 24]

(58) Mér {*virðist/virðast} Þeir vera skemmtilegir. (Icelandic)

me-DAT seem-{3.SG/3.PL} they-NOM be-INF interesting

‘It seems to me that they are interesting’

[from Boeckx 2004: 24]

More phenomena like (57) and (58) are provided by Boeckx (2004). Such is the case of Hindi long distance object agreement, a pattern whereby a verb takes an infinitival

complement and agrees (at a distance) with the object of that infinitive, as well as with the infinitive itself.

- (59) Vivek-ne [kitaab parh-nii] chaah-ii. (Hindi)
 Vivek-ERG book-FEM read-INF-FEM want-PFV-FEM
 ‘Vivek wants to read the book’

[from Boeckx 2004: 25]

Boeckx (2004) analyzes examples like (59) at length, proving SPEC-H, Attract-F, and covert phrasal movement based analyses to be inadequate.³³ Instead, Boeckx (2004) provides evidence favoring a checking that establishes (long-distance) agreement under c-command, a possibility first explored in Raposo & Uriagereka’s (1990) long-distance Case assignment under government, as roughly pictured in (60):

- (60) *Case Assignment (at a distance)*

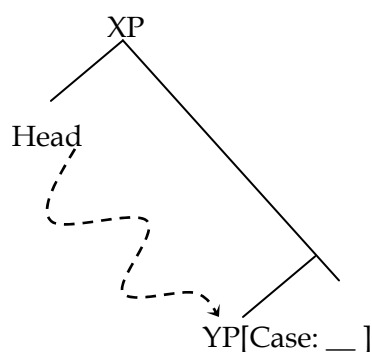

Chomsky (1995b: 262) was the first to cast doubt on a configurational approach to checking. The idea was that, if a feature F was to be checked, then only F should move, and not the entire category containing F. Chomsky (1995b) phrased this intuition by means of an operation which treated F(eature)-Movement as a species of head movement: *Attract-F*. However interesting, *Attract-F* fell short of explaining why, apart from the checked F, the entire category is sometimes moved.³⁴ Chomsky (1995b: 265)

³³ This is not to say that agreement is insensitive to SPEC-H configurations; as Boeckx himself notes (see Boeckx 2000a; 2003b; 2006b), long-distance agreement only forces [number], not [person], checking, as the very examples in (54) and (55) show. See chapter 3.

³⁴ Chomsky (1995b) also argued that, together with the checked F, formal features (FF) also raise. Since nothing hinges on this aspect, I will ignore it (see Chomsky 1995b: 265-266)

blamed the PHON component for this, when he suggested to “tentatively assume, then, that only PF convergence forces anything beyond features to raise.”³⁵

A more powerful and conceptually sound critique is held in Chomsky (2000: 123-126), where: firstly, checking domains are dispensed with entirely, and, secondly, a much refined notion of checking is introduced, embodied by the operation Agree. Let us first consider the elimination of checking domains:

Reinterpretation of Attract in terms of Agree eliminates the need to introduce “checking domains.” That is a step forward. The notion is complex, and furthermore unnatural in minimalist terms; *feature checking should involve features, nothing more*, and there is no simpler relation than identity. More importantly, the notion is irrelevant for the core cases: elements merge in checking domains for reasons independent of feature checking; and feature checking takes place without dislocation to a checking domain.

[from Chomsky 2000: 126 –emphasis added, AJG]

The reader may recall from section 3.1.1. that, according to Chomsky (to appear), Merge provides two syntactic relations: set-membership and Probe-Goal. It is the latter that interests us now. Chomsky (2000; 2001) introduces Agree in the context of what can be called the Probe-Goal framework. Roughly put, Chomsky (2000; 2001) assumes that *Core Functional Categories* (CFC: C, T, and *v*) are introduced in the syntax with a set of *uninterpretable* φ -features (the nominal features [gender], [number], and [person]), which must be deleted. As Pesetsky & Torrego (2007) argue, (un)interpretability does not depend on features as such, but on the LIs that bear them: if a feature F makes a semantic contribution in a given LI, then that F is interpretable in that LI. Let us therefore assume (61):

(61) **FEATURE INTERPRETABILITY**

A feature F is interpretable at SEM if it makes a semantic contribution in the LI in which it appears, otherwise F is uninterpretable and must be valued and deleted

(61) can be regarded as a way to encode the fact that φ -features are interpretable in nouns, not verbs.

³⁵ From this perspective, movement of DP can be regarded as a ‘morphological repair strategy’ (see Chomsky 1995b: 263, Lasnik 2003a, and Ochi 1999): by moving the DP, the ‘extracted F’ can be put back (that is, restored) within the morphological structure of the DP.

An issue that becomes intriguing (if syntax is blind to semantic demands) is whether interpretability must somehow be relevant during computation. To put it in provocative terms: why should syntax care about SEM matters in the realm of feature checking? Assessing this issue from a different angle, Chomsky (2001: 5; 2004: 116) entertains the idea that uninterpretable features enter the derivation unvalued. Viewed that way, everything syntax cares about is *valuation* (a formal notion), not *interpretability* (SEM's). Accordingly, LIs come from the lexicon not as in (62a) (where *u* and *i* stand for 'uninterpretable' and 'interpretable'), but as in (62b) (where '3' indicates a random value, a notation I will refine shortly):

(62)

- a. LI [*i*F] (interpretable) vs. LI [*u*F] (uninterpretable)
 b. LI [3F] (valued) vs. LI [_ F] (unvalued)

Slightly more precisely, we expect features to adopt the format in (63), with two components that must be distinguished: an *attribute* (a given property or dimension) and its *value*.

(63) [number: SG]

Notice that (63) sharply differs from former accounts in its accuracy: the simple [\pm F] distinction is eliminated in favor of more fine-grained specification. In this regard, as Boeckx (2006a) notes, it is an intriguing fact that most features seem to be able to display three values, as shown in (64). Curiously, the same picture does not hold in the case of some features, importantly so in the case of semantic ones, like [specific], [focus], [interrogative], or [topic].³⁶

³⁶ One might, of course, come up with a list of values to the features [wh], [topic], [neg], etc.: focus can be contrastive or non-contrastive; wh can be *in situ* or non *in situ*; negation can be internal or external, and so on. I put these possibilities aside.

(64)

FEATURE	VALUE	FEATURE	VALUE
<i>person</i>	[first, second, third]	<i>wh</i>	± at most
<i>gender</i>	[masculine, feminine, neuter]	<i>topic</i>	± at most
<i>number</i>	[singular, plural, dual]	<i>focus</i>	± at most
<i>case</i>	[structural, inherent, oblique]	<i>neg</i>	± at most
<i>tense</i>	[past, present, future]	<i>specific</i>	± at most
<i>mood</i>	[indicative, subjunctive, (conditional)]		

Under the hypothesis that search for a value is what checking amounts to, Chomsky (2000; 2001) argues that T and v^* are taken from the lexicon with their φ -feature bundle unvalued: that makes them act as a Probe looking for a Goal (i.e., the closest c-commanded element with a matching feature).

According to Chomsky (2000; 2001), the Probe-Goal dependency operates under the following conditions:

(65) CONDITIONS ON AGREE

- a. Probe and Goal must be active for Agree to apply
- b. Agree divides into Match and Valuation
- b. Probe must contain a full set of features (it must be complete) to delete the uninterpretable FF of matched Goal

[adapted from Chomsky 2001: 6]

There are three key notions in (65) that deserve clarification: *activity*, *Match*, and *completeness*. Let us first explain what activity is. Building on the long standing intuition that inflectional features trigger checking operations, Chomsky (2000: 123) proposes that uninterpretable morphology renders syntactic objects active –“able to implement an operation,” as he puts it. Assume (66), accordingly:

(66) ACTIVITY CONDITION

Uninterpretable (unvalued) morphology renders syntactic objects ‘active’

Keeping things to the A-systems, the standard assumption is this: ϕ -features activate CFC, while Case does nominals.³⁷ Importantly, uninterpretable features must be deleted (we will see how in chapter 2) before the derivation is mapped to SEM, since, for instance, we do not want the [number] feature to be present on T in the semantics.

For reasons that will become clear when the notion of *phase* (see section 3.1.) is explored, activity operates within computational boundaries: features eventually get a value, becoming ‘inactive.’ What effects does inactivity have? In the case of nominals, for example, Chomsky (2000: 123) holds that deletion of Case renders them “frozen in place.” Under that scenario, so-called *Hyperraising* (see Lasnik & Boeckx 2006 and Ura 1996) can thus be understood in terms of freezing: once structural Case has been checked, a DP like *John* in (67) is useless for further computational business:

(67) *_{[CP C [TP John_i T seems [CP C [TP t_i T t_i likes Mary]]]]}

Let us express the fact that syntactic objects cannot engage additional computational dependencies after structural Case checking as in (68).^{38 39}

(68) **FREEZING EFFECT (non-final version)**

DPs whose Case have been checked are computationally inert

The next notion I want to focus on is that of Match. Chomsky (2000; 2001) argues that Agree is parasitic on a Match relation: a dependency sensitive to the type of feature two LIs share (what I called *attribute*), not its *value*.

³⁷ The proposal is severely restricted, and it remains silent about activity in other types of dependents, like wh-phrases (e.g., *who*) or syntactic objects introduced by a preposition (e.g., *by Peter*). Are those active as well? I return to this issue in chapter 2, arguing for a view whereby the same type of activity cannot be assumed for both A and A-bar dependents.

³⁸ See Wexler & Culicover (1981) for the original formulation of a *Freezing Principle*. See chapters 2 and 4 for additional discussion about “freezing” mechanisms.

³⁹ I will modify this definition of freezing in chapter 2, building on Boeckx’s (2006b) ideas. See Nevins (2004) for an alternative account whereby it is not Chomsky’s (2000; 2001) *Activity Condition* that matters, but his *Single Case Constraint*, a universal constraint that DPs cannot be assigned more than one Case value. See Richards (2007) for additional discussion about multiply Case marked DPs.

(69) **MATCH**

F and F Match if they belong to the same attribute class (e.g., [number], [Case], etc.), independently of value (e.g., singular vs. plural, nominative vs. accusative, etc.)

Graphically, the [person] features in (70) Match, although only the first one needs to receive a value:

(70) LI [person:] . . . LI [person: 2nd]

Consider a particular example to make things more transparent. Take (71):⁴⁰

(71) [CP C [TP T_[φ] [v*P John_[3.SG] v*_[φ] [VP loves his daughters_[3.PL]]]]]

In (71) we have a transitive structure, headed by the light verb *v**. In (72), *v** probes *his daughters* and T does *John*.

(72) [CP C [TP T_[φ] [v*P John_[3.SG] v*_[φ] [VP loves his daughters_[3.PL]]]]]

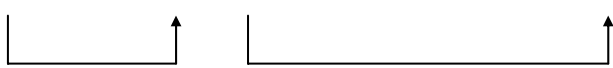

In both cases, the φ-feature bundle of the Probe and that of the Goal match, and the Goal's φ-features assign a value to the Probe's. The second step, driven by matched Goals, we can call *Valuation*, following Boeckx (2003c):

(73)

- a. Probe [φ] ↔ [3.PL] Goal Step 1: Match
- b. Probe [3.PL] ← [3.PL] Goal Step 2: Valuation

Crucially, Chomsky (2000; 2001) claims that Agree is parasitic on Match, but not vice-versa. In other words: Valuation requires Match, but not every Match is followed by Valuation.

⁴⁰ From this point on I will represent features with precise values. In the case of unvalued nominal features, I will keep using the Greek letter “φ” to indicate the bundle containing [person] and [number].

There are two cases of Match not followed by Valuation worth considering: in the first one, Match relates two syntactic objects, one of which lacks some of the relevant features for the checking operation to succeed: a *defective* element. Chomsky (2001) restricts defectiveness to ϕ -features on CFCs, claiming that defective ϕ -bundles contain just the [person] attribute:⁴¹

(74) **DEFECTIVENESS**

An LI is defective if it lacks some attribute(s) of a given class

(75) **DEFECTIVE CFC**

a. T_{def} : raising and ECM structures

b. $v^*_{\text{def}}(v)$: unaccusative structures

The consequences of ϕ -defectiveness can be witnessed in the context of structural Case assignment. Consider (76):

(76) $[_{\text{CP}} C [_{\text{TP}} T_{[\phi]} [_{v^*P} v_{[\phi]} \text{arrived John}_{[\text{3.SG}]}]]]$

In (76) we have an unaccusative structure, headed by a ϕ -defective v^* (dubbed v by Chomsky 2001). Though defective, v still acts as a Probe, and scans its domain for the closest Goal, finding the object DP *John*: they match, and the [number] feature of v is valued. However, due to v 's defectiveness, *John* cannot get Case, so it remains active, needing another Probe to finish the job v was supposed to do. That role is fulfilled by T , which, as soon as is introduced in the derivation, 'bypasses' v , matches the object DP, and assigns it nominative Case. The important thing to note here is that the object is matched twice, by v and T , but only establishes Agree proper with the latter, for only T is ϕ -complete.

⁴¹ A non-CFC considered by Chomsky (2001) is *Prt* (Participle), which due to its adjectival nature, lacks [person] and cannot assign structural Case. For Chomsky (2001), only T and v^* can be defective. Also important is the question of whether defectiveness can be found in a paradigm different from nominal features; that is to say, can other type of features (i.e., tense, mood, etc.) be defective in some manner? In Chomsky's system, these questions have not been addressed. For additional discussion about defectiveness, see chapter 2.

A second case of Match not followed by Valuation arises with LIs that contain both interpretable and uninterpretable features, DPs being the prototypical case: they bear Case and φ -features. Recall that, under Chomsky’s (2000; 2001) system, whenever Case is assigned a value, the DP is frozen in place: but that should only affect Case, not φ -features, which remain visible due to their interpretability (see Chomsky 2000: 127), potentially giving rise to what Chomsky calls *defective intervention effects* (see chapter 3). Bearing that in mind, let us redefine *Freezing Effect* as in (77):

(77) **FREEZING EFFECT (non-final version)**

DPs whose Case have been checked are rendered computationally inert, but their interpretable FF remain ‘visible’ for Match, triggering *defective intervention effects*

The relevant configuration for this second variety of Match without Valuation to occur is thus as in (78), where the Probe wants to match the Goal₂, but inactive Goal₁, which is closer under strict c-command metrics, interferes, yielding a minimality effect.

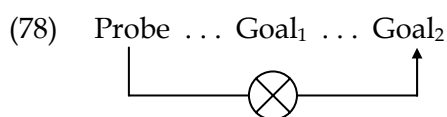

Boeckx (1999a; 2000a; 2003a; 2003b; 2004; 2006b) and Boeckx & Niinuma (2004) extensively discuss examples of the (78) sort. Two such examples concern Bonet’s (1994) *Person-Case Constraint* (PCC) and the so-called *Experiencer Paradox* (see Boeckx 1999a; 2000a, Lasnik & Boeckx 2006, and Ura 1996 for relevant discussion). In both cases, the pattern of (78) is at stake. Consider a PCC case like (79):

(79)

a. *Pedro le me envía. (Spanish)

Pedro CL-to.him-3.SG-DAT CL-me-1.SG-ACC send-3.SG

‘Pedro sends me to him’

b. Pedro me lo envía. (Spanish)

Pedro CL-to.him-1.SG-DAT CL-him/it-3.SG-ACC send-3.SG

‘Pedro sends him to me’

[from Ormazabal 2000: 241-242]

As the reader may see, Bonet's (1994) PCC forces accusative marked DPs to appear in default [person: 3] in the presence of dative DPs. Configurationally, this falls into place only if the indirect object intervenes between v^* and the direct object, blocking Agree (v^* , DO):⁴² in its way down to the direct object, the ϕ -Probe of v^* matches the indirect object, checking [person], with the subsequent effect that the direct object can only show up in the default value for that feature.

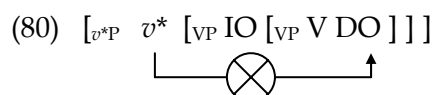

Experiencer Paradox cases have also received much attention in the recent literature (see Boeckx 1999a; 2000a and references therein). Torrego (1996b; 1998a; 2002) offers the most detailed study of the *Experiencer Paradox* for Spanish, noting that experiencer clitics block raising of embedded subjects: *Juan*, in (81).⁴³

- (81) Juan_i (*me) parece [_{TP} t_i T_{def} tener problemas] (Spanish)
 Juan CL-to.me seem-3.SG have-INF problems
 'Juan seems (to me) to have problems'

I will consider defective intervention configurations in more detail in chapter 3. For now, my goal was rather modest: to show that phenomena like the PCC and the *Experiencer Paradox* constitute strong evidence in favor of Chomsky's (2000) claim that Match exists independently of Agree (Valuation).

In this section I have laid out the basic properties of Chomsky's (2000; 2001) Probe-Goal framework to the Case/agreement systems: the operation Agree, and its subcomponents Match and Valuation. An important consequence of this shift is that checking relations are refined in important ways: the notion of "feature" (technically, a valued attribute) becomes more accurate, and dedicated checking configurations are dispensed with –all we need is a (long distance) dependency between a Probe and a

⁴² This assumes, with Boeckx & Niinuma (2004) and Torrego (1998a) that IO c-commands DO in the base structure. See Jeong (2006) for ample discussion.

⁴³ Torrego's (1996b) analysis is discussed (and rejected) by Ausín (2001), who argues that Spanish lacks *bona fide* raising structures, *parecer* (Eng. *seem*) being a modal –not a raising- verb. I return to Ausín's (2001) account and its implications in chapter 2.

Goal, mediated by c-command. By this very logic, if a SPEC-H configuration arises, it is not because of checking itself, but because of either cyclicity or discourse-oriented semantics reasons, as I will defend in chapter 2. Consequently, and bearing in mind that we assumed (10) in section 3.1.1., repeated here as (82),

(82) **MERGE ASSUMPTION**

Merge only operates with LIs, not features

we can assume (83):

(83) **AGREE ASSUMPTION**

Agree only operates with features, not LIs (or configurations)

4. Locality and the Concept of Cycle

In this final section I would like to address whether the operations considered up to this point, Merge and Agree, must obey some general principles of computational economy. In particular, I want to discuss the hypothesis that the system is ruled by locality constraints determining whether operations occur within specific domains: the *phases*.

Ever since Chomsky et al.'s (1956) introduction of the *cycle* in accounting for word stress, the idea that operations take place within a local domain has become a cornerstone of contemporary syntactic theory.⁴⁴ The gist of such an idea is easy to spell out: taking structure building algorithms to be monotonic (that is, if the input of an operation A is preserved and can be identified in its outcome) certain syntactic domains have a especial status in requiring operations to apply within their boundaries, without going back to already passed stages (i.e., without backtracking), or moving on to subsequent ones (i.e., without look-ahead), thus deploying some sort of computational efficiency that invokes economy metrics, since previous stages can be forgotten as the derivation unfolds. This was the essence of Chomsky's (1973) *Strict Cycle Condition*:

⁴⁴ See Boeckx (2007) and references therein (notably, Abels 2003 and Lasnik 2006) for discussion.

(84) **STRICT CYCLE CONDITION**

No rule can apply to a domain dominated by a cyclic node A in such a way as to affect solely a proper subdomain of A dominated by a node B which is also a cyclic node

[from Chomsky 1973: 97]

Graphically, cyclicity can be conceived of as depicted in (85), where computation moves from stage A to stage B, and then to stage C in a step-by-step fashion: once the first cycle is completed (and transferred to the interfaces), the system moves on to the second one, and so on.

(85) **CYCLIC (MONOTONIC) COMPUTATION**

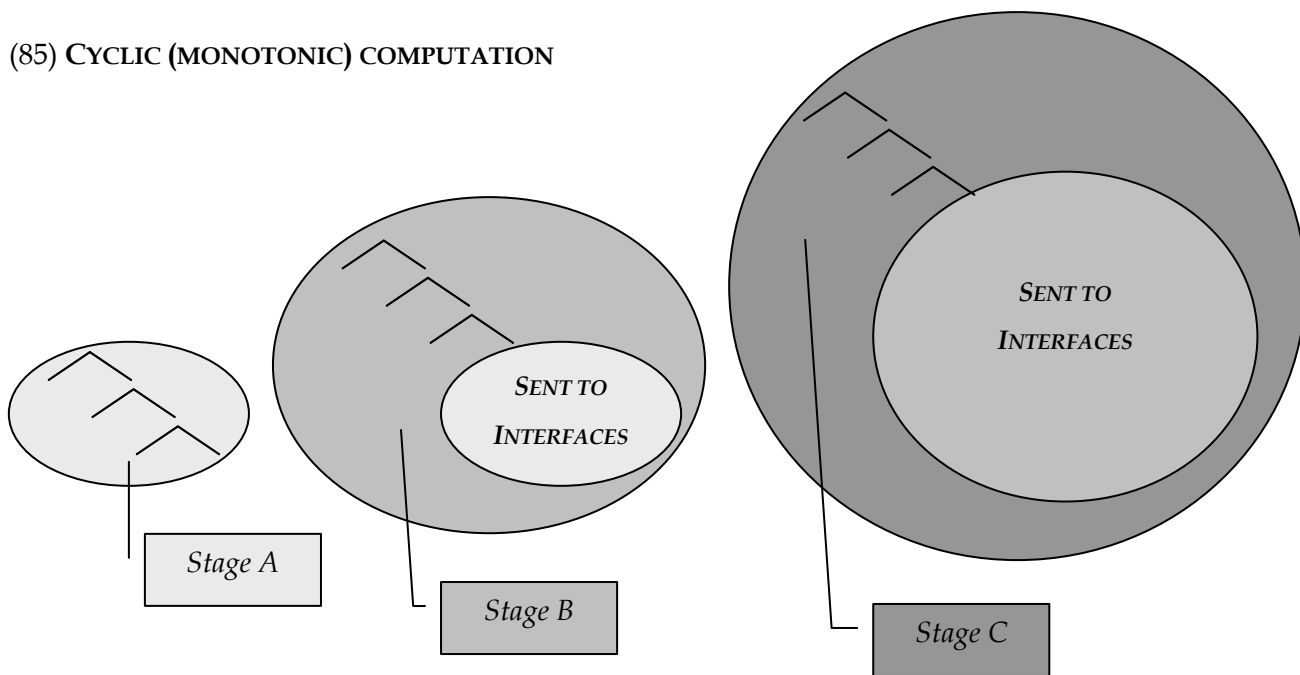

Different empirical phenomena suggest that computation proceeds roughly as pictured above, with the system caring about lexical arrays placed in a local workspace (see Lasnik & Uriagereka 2005: ch. 7 for discussion). Take the case of anaphoric dependencies (binding), which are licensed within a given domain –typically, a clause:

(86)

a. John_i shaved himself_i

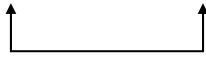

b. *John_i said Peter shaved himself_i

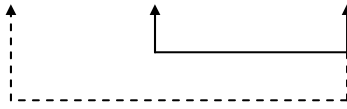

too far away

In (86b), it is impossible for *himself* to be bound by matrix *John*, which appears to be too far away for the relevant dependency to emerge. If *John* and *himself* are brought together, binding is fine again:

(87) Peter said John_i shaved himself_i



Intuitively, the situation just witnessed boils down to a structural constraint: the system cannot go beyond a clausal boundary in order to relate *himself* to its antecedent. More precisely, the system appears to relate *himself* to the first DP available within that domain: *Peter* in (86b).

Lasnik & Uriagereka (2005: 234 and ff.) capitalize on this minimality fact in order to account for (88), which involves the same kind of minimality based explanation:

(88) *You saw [DP my_i pictures of yourself_i]

In (88), the anaphor *yourself* cannot wait until the derivation reaches the pronominal *you*: since possessive *my* is a closer potential antecedent within a domain (here, the DP), *my* and *yourself* are coindexed. Notice that this scenario is only consistent with some kind of optimization procedure, the same kind of optimization that cyclicity is designed to yield.

Consider next the example in (89), where the anaphor *herself* can take as its antecedent either *Susan* or *Mary*:

(89) [_{CP} [Which pictures of herself_i] C did Mary_i say [_{CP} that Susan_i likes t_i]]?

The datum in (89) is puzzling in that *herself* can be coindexed not only with its base clause-mate, the DP *Susan*, but also with upstairs *Mary*. Coindexation with *Susan* follows if, prior to wh-movement, *herself* is in a position c-commanded by *Susan*, as predicted by reconstruction:

(90) [_{CP} Mary_i said [_{CP} that Susan_i likes [_{DP} which pictures of herself_i]]]?

However, if binding requires c-command between binder and bindee, coindexation between *Mary* and *herself* in (89) should be ruled out –but it is not. To solve this tension, it is assumed that the wh-phrase passes through a position close enough to *Mary* where the c-command condition can be satisfied: SPEC-C of the embedded clause, the so-called ‘escape hatch.’ Actually, facts like (91) provide evidence for that invisible step:

(91) Mary said [_{CP} [which pictures of herself]_i C Susan likes t_i]

The same kind of long-distance dependency can be made more complex:

(92) [_{CP} Which pictures of herself_i did Mary say [that John thinks [that Mary likes t_i]]]?

The question that arises is how the dependency between the surface and base positions of wh-phrases (also called *filler* and *gap*) is created. Do they move from their base position to matrix SPEC-C targeting every possible landing site (i.e. every specifier along the movement path) or by targeting only dedicated positions between base and surface positions? There are two main approaches to this issue (see Boeckx 2007):

(93) **FILLER-GAP RELATIONS**

- a. Uniform: movement proceeds through every node along the path⁴⁵
- b. Punctuated: movement targets dedicated positions (escape hatches)

⁴⁵ As Abels (2003: 19) notes, uniform accounts to filler-gap relations further divide into *quasi uniform* and *truly uniform*. Under the latter, movement proceeds strictly through each and every possible landing site, including X' projections; on the other hand, *quasi uniform* paths only target XP projections.

Robust evidence in the literature has accumulated in favor of movement occurring via intermediate steps: phenomena like subject-verb inversion, agreeing complementizers, quantifier float, or reconstruction, to name but a few,⁴⁶ indicate that long-distance movement does not proceed in a unique long leap, but making shorter (i.e., more local) moves instead, in accord with cyclic restrictions. Assuming so, what remains to be decided is *how short* this step-by-step movement is.

Within the generative tradition, the punctuated option has overwhelmingly been the chosen one. Since Chomsky's (1973) *Subjacency Condition* and its "bounding nodes," A-bar movement has been taken to proceed through dedicated escape hatches.

(94) **SUBJACENCY CONDITION**

No rule can involve X, Y, X [being] superior to Y, if Y is not subjacent to X

[from Chomsky 1973: 103]

The same scenario was essentially maintained in the *Barriers* model of Chomsky (1986a), whose main innovation was adding the specifier of V (to be precise, an adjoined position, under the segment-category distinction seen in section 1.3.1. above) as a second obligatory landing site for successive cyclic movement.

In these approaches, movement operates by 'leapfrogging' from one escape hatch to the next one bypassing other available positions along the way, roughly as illustrated in (95):

⁴⁶ See Abels (2003), Boeckx (2003a; 2007), and Lasnik & Uriagereka (2005: ch. 7) for discussion.

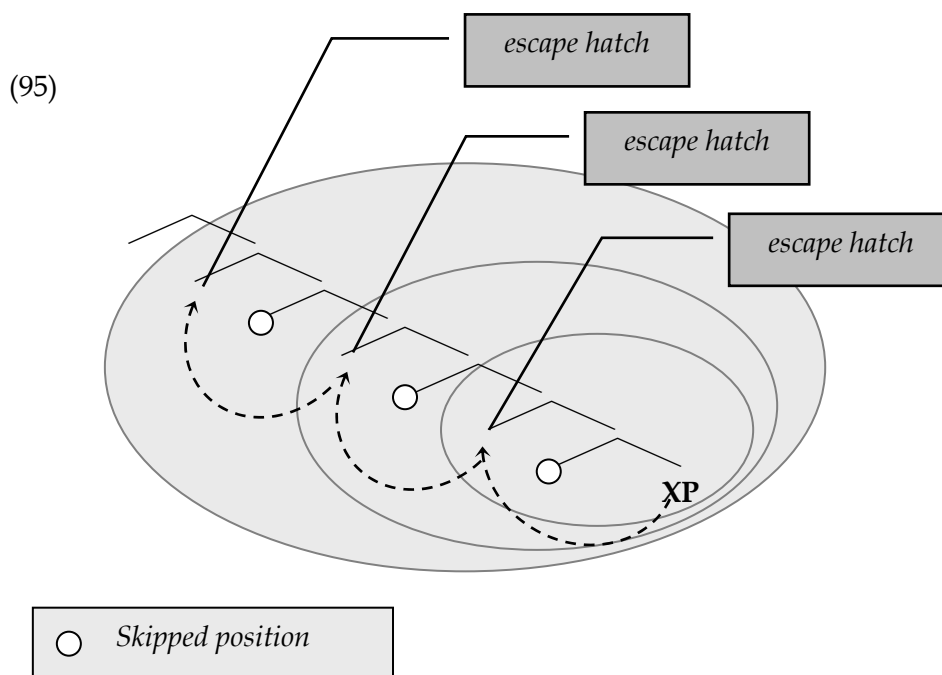

Let us go back to the main discussion: the notion of *cycle*. In chapter 2 I will consider the *phases* (the current counterpart of the cycle) in detail, but for now all I want is to emphasize the nature and importance of such notion in a non-technical way. Since Chomsky (1991) (and also in Chomsky 1986a; 1986b), the idea that computation proceeds sticking to economy considerations of the type I just mentioned is pursued in a very explicit fashion: that was the logic behind movement being a Last Resort strategy, derivations (with the same LAs) being compared and filtered out, having sequential access to the lexicon, dispensing with *ad hoc* symbols (inclusiveness), simpler operations (Merge) outranking more complex ones (Move), eliminating non-primitive relational dependencies (e.g., government, m-command, etc.), adopting BPS, etc.

At present, theorizing is divided with respect to which amount of structure corresponds to the cycles: on the one hand, there is Epstein et al.'s (1998) project (see Epstein 1999 and Epstein & Seely 2002), for which every application of a transformational rule constitutes a cycle/phase, and, on the other hand, there is Chomsky's (2000; 2001; to appear) orthodox *Phase Theory*, which argues in favor of a weak derivational approach whereby cycles involve a representational residue.⁴⁷

⁴⁷ In between these two poles, alternative approaches to cyclic domains are available, invoking different criteria to identify them: command units (see Uriagereka 1999a), X-bar Theory (see

Putting details aside, the difference is clear in (96). As can be seen, under Epstein et al.'s (1998) model, derivational chunks are handed over to the interfaces as soon as possible, whereas Chomsky's (2000; 2001; to appear) allows for them to 'grow' before submission to the interfaces.

(96) a. CYCLIC SYNTAX
à la Epstein et al. (1998)

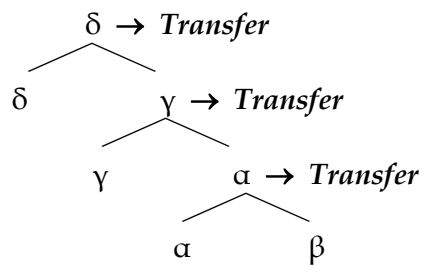

b. CYCLIC SYNTAX
à la Chomsky (2000; 2001; 2004; to appear)

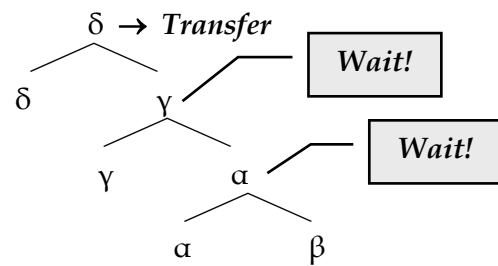

Intuitively, Chomsky's (2000; 2001; to appear) conception increases memory load. One can reinterpret that naïve observation by saying that Chomsky's cycles involve short-term memory, their information being available only for a certain period of time. This is consistent with the contex-sensitive status of nature languages, which thus qualify as type 1 languages according the so-called *Chomsky Hierarchy*.

(97) *The Chomsky Hierarchy* (see Chomsky 1956)

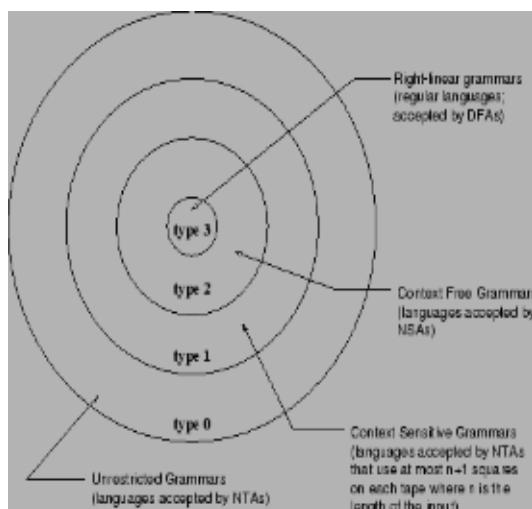

TYPES OF FORMAL LANGUAGES

- Type 0 → Recursive Languages**
Sets of formal objects of any computational complexity
- Type 1 → Context-sensitive Languages**
Sets of sets of sequences of symbols (i.e., chains)
- Type 2 → Context-free Languages**
Sets of sequences of symbols (i.e., phrases)
- Type 3 → Regular Languages**
Sequences of symbols.

Boeckx 2006a), predication (see Den Dikken 2006), categorial information (see Marantz 2000), etc.

Uriagereka (forthcoming) reinterprets the Chomsky Hierarchy in I-Language terms, capitalizing on memory in order to establish the relevant distinctions.⁴⁸

(98)

- a. Regular languages (strings of symbols)
- b. Context-free languages (sets of symbol strings)
- c. Context sensitive languages (sets of symbol string sets)
- d. Recursive languages (sets of formal objects of any computational complexity)

[from Uriagereka forthcoming: ch. 7]

Importantly, memory here is not to be understood as related to *performance* (the actual use of the FL, constrained by aspects that vary from individual to individual: attention, age, physical stage, etc.), but to the system's resources, the generative procedure itself.

Plausibly, as argued by Uriagereka, the operations instantiating the types 1 and 2 of grammars correspond to internal Merge and external Merge respectively: phrases and chains. What about types 0 and 3? Uriagereka (forthcoming) assumes that type 0 corresponds to the *Turing Machine* and is therefore out of the FL.⁴⁹ Type 3 cannot run the same fate, though, since the Chomsky Hierarchy has an implicational nature: more complex levels presuppose simpler ones. The rules in (99) are typically associated to formal languages of type 3:

(99)

- a. $A \rightarrow \alpha \gamma$
- b. $A \rightarrow \gamma \beta$

The basic property of these rules concerns their memory restrictions: being incapable of keeping track of complex associations (i.e., phrases), regular rules can only

⁴⁸ In this discussion I am putting aside memory issues from a broader perspective (e.g., processing and the like). See Drury (2005) for discussion.

⁴⁹ The term 'machine' is not intended in the contemporary sense. Alan Turing used 'machine' in the same way we nowadays use the term 'program.'

operate with immediately adjacent elements, as happens in the case of Markovian chains.⁵⁰

It is obvious that natural languages present phenomena which need more memory than that provided by the rules in (99). This can be tested in domains like ellipsis. Consider (100), taken from Uriagereka (forthcoming):

(100) Matilda kicked the bucket and so did farmer Smith, who was milking her.

As Uriagereka notes, it is not possible to interpret *kick the bucket* in an idiomatic and non-idiomatic/literal fashion in (100): ellipsis poses a parallelism constraint that blocks that possibility (see Fox 2000). Consequently, the plausible interpretation that Matilda kicked the bucket on which Smith was milking her, and, as a result, he died is generally unavailable. (100), therefore, reinforces the claim that natural languages go beyond finite-state processes: for ellipsis resolution to work as indicated we need some kind of memory that goes beyond what (99) gives, as we need to keep a record of the chunk of structure that is deleted and interpreted in some other place via ellipsis.

Examples like the previous one suggest that computation must indeed ‘wait’ until certain amount of structure is built up, as we see in (96b).⁵¹ Relations of that sort can be captured by means of external Merge, but this is not enough to encode long-distance dependencies within phrase markers. To see why, consider (101): that configuration cannot capture any possible dependency between C and B.

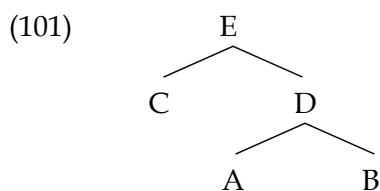

⁵⁰ Or *Markov Chain*, in honor of the Russian mathematician Andrei Markov. These are sequences of symbols as such as “ $X_1, X_2, X_3, X_4, \dots$ ” where whatever precedes a stage s depends on what happened in an immediately previous stage $s - 1$.

⁵¹ The same result is guaranteed if derivations unfold as Epstein et al.’s (1998) suggest, but at the cost of having some post-syntactic mechanism to correctly ‘glue’ the various cashed out chunks together in a way that the relevant subject-object (hierarchical) asymmetry is captured. See Uriagereka (forthcoming: ch. 7) for discussion of some phenomena that cannot be captured by Epstein et al.’s (1998) system.

The context of all elements in (101) is formally well defined (the context of A is “A, B,” that of C is “E, D,” etc.). However, with the intrinsic limitations of external Merge we cannot express a connection between C and B, for this requires a context sensitive procedure. As discussed above (section 3.2.), this type of (long-distance) dependency can be implemented in terms of Attract-F, Agree, or internal Merge, and can be formally spelled-out by means of the algorithm in (102), where A is a terminal symbol, and α , β , and γ are sequences of terminal or non-terminal symbols:

$$(102) \alpha A \beta \rightarrow \alpha \gamma \beta$$

Context sensitivity follows, in (102), from the variables α and β , which define A’s context, allowing us to know whether this element can be replaced by γ , as the rule dictates. Using any of the mechanisms mentioned above predicts the possibility of so-called intervention effects (in the sense of Rizzi 1990; see section 3.2. and chapter 3): if the relevant property shared by C and B is also possessed by A, then A will interfere. But then, once again, we need for syntax to wait, caring about a complex derivational workspace containing, at least, C (the Probe), B (the Goal), and A (the intervener).

Suppose we phrase these ideas by assuming that there is a phase bounded memory ruling computational operations like the ones I mentioned. Let us refer to this simply as *Phase-Level Memory*:

(103) **PHASE-LEVEL MEMORY**

Computational operations operate within phase boundaries

Chomsky (to appear) refers to (103) when considering deletion of traces. In his words:

There must be some way to identify internally-merged α with its copy, but not with other items that have the same feature composition: to distinguish, say, “John killed John” or “John sold John to John” (with syntactically unrelated occurrences of *John*), from “John was killed John” (with two copies of the same LI *John*). That is straightforward, satisfying the inclusiveness condition, if within a phase each selection of an LI from the lexicon is a distinct item, so that all relevant identical items are copies. *Nothing more than phase-level memory is required to identify these properties at the semantic interface C-I, where the information is required.*

[from Chomsky to appear: 12 –emphasis added, AJG]

Synthesizing, there are grounds enough to approach linguistic processes by taking Narrow Syntax to operate with small LAs that are sent to the interpretive components in a cyclic fashion. This (rather old) idea is supported not only on empirical grounds (as we have seen), but also fits with the type of economy-oriented approach that minimalism envisages: under cyclic computation, the system can concentrate on particular workspaces, being thus able to forget about previous stages, which reduces computational burden.

Considering matters of this sort, Chomsky (2007) underscores the role of ϕ -features as cyclic landmarks. In particular, Chomsky (2007) suggests that morphology in natural languages is an optimal device to signal Transfer points (the *phases*). In the next chapter I will emphasize this possibility, arguing that the most compelling reason for having cyclic computation has to do with the valuation and eventual deletion of uninterpretable features.

CHAPTER II

PHASE THEORY AND PHASE SLIDING

1. Introduction

This chapter explores the syntactic dependencies between *C*, *T* and *v** in *Null Subject Languages* (henceforth, *NSLs*), which I argue to be the locus of parametric choices. Exploring Chomsky's (2000; 2001; 2004; to appear) *Phase Theory*, I consider a possible formalization of the idea that *T* becomes a phase head in *NSLs*, according to what I will call *Phase Condition*:

(1) PHASE CONDITION

Uninterpretable morphology is phase bounded

The *Phase Condition* in (1) is different from the *Phase Head – EF Correlation* (see below) that was argued for by Gallego (2005) in order to make *T* 'phasal,' even though both observations achieve the the intended outcome. For Gallego (2005), *T* became a phase head, since, due to *v**-to-*T* movement, it ended up having EPP features (in the sense of Chomsky 2000). However plausible, it was soon noticed that such a trait was unlikely to be a defining property of phases: rather, as we shall see, the most salient property of phases is related to the thesis that uninterpretable morphology must be valued and deleted when the relevant chunks of structure are transferred to the interfaces (see Chomsky 2001 and Pesetsky & Torrego 2001).

Evidence from different empirical domains will be provided in order to argue that the phase system of *NSLs* is different from that of English, with *T* showing phase effects –a claim that appears to be well-supported empirically, hence deserves careful consideration.

The scenario just described poses a non-trivial conceptual puzzle which is not easy to address: why should phases (or any relevant cycle, for that matter) differ cross-linguistically? In order to overcome this situation, it will be argued that the phase effects manifested in *T*, however pervasive and robust, are derivative from verb

movement: when undergoing head movement, v^* forms a complex label with T by means of a process that, as in Gallego (200), I will keep on referring to as *Phase Sliding* (see section 3.4.). Hence, here I will not argue that v^* pied pipes EPP features: instead, I will hold that T shows phase effects simply because of v^* -to-T movement.

The general idea to keep in mind, though phrased in current –phase based– terms is in truth an old one: it is embodied in Baker’s (1988) *Government Transparency Corollary*, in Kayne’s (1989) influential work of clitic climbing, in Rizzi’s (1978; 1982) parametrization of bounding nodes, and in Contreras’ (1976; 1978; 1980) seminal studies on discourse oriented semantics in Romance. Interestingly, the idea is also present in Chomsky’s (1986a) *Barriers*, where TP (at that time, IP) was considered an anomalous (defective) functional projection, becoming a barrier just by inheritance.

The recent literature shows a growing skepticism about Chomsky’s (2000; 2001; 2004; to appear) *Phase Theory*, and various arguments have been presented in order to cast doubt on their benefits if compared to previous minimalist frameworks (see Boeckx & Grohmann 2007 and Epstein & Seely 2002). I will not try to review those arguments or compare the alternative theoretical options entertained (in this respect, see Abels 2003, Fortuny 2007, Marušič 2005, Mayr 2005; 2006a, and Richards 2004; 2006a). Skepticism may also emerge with respect to *Phase Sliding* too: the idea that Romance T is special is not brand-new, so the reader may wonder whether phrasing it within *Phase Theory* has any conceptual or empirical gain. I will argue it does in that it allows us to capture several empirical observations in a unitary fashion.

Objections to *Phase Sliding* do not end here: this mechanism must, in addition, deal with head movement, which has been cornered to the PHON components through rather compelling arguments (see Abels 2003, Boeckx & Stjepanović 2001, and Chomsky 2001), although it is fair to say that the issue is far from being settled (see Den Dikken 2006a, Donati 2006a, Matushansky 2006, Roberts 2006, and Vicente 2007). Clearly, *Phase Sliding* depends on head movement being genuinely syntactic, so for it to be tenable unequivocal arguments that v^* -to-T movement takes place within Narrow Syntax must be provided.

This chapter also explores the consequences of *Phase Sliding*, trying to find out whether it has any bearing on the barrier status of TP, as argued by Uriagereka (1999b).¹ Here two possibilities must be considered: is the (allegedly) phasal nature of TP a side-effect of *v**-to-T movement (as in Gallego 2005) or a consequence of SPEC creation (as in Uriagereka 1999b)? But much more important, as we will see, is the issue of why the system cannot wait until the entire CP is built and submit it to Transfer, in a standard fashion. The intuition I want to pursue is that morphology forces that ‘extra’ process.

The chapter is divided as follows: section 2 explores Chomsky’s (2000; 2001; 2004; 2005; 2007; to appear) *Phase Theory* at length; section 3 assesses the role of Case in the computational system, considering Pesetsky & Torrego’s (2001; 2004; 2006; 2007) recent work and the tight relation between Merge and Agree; in section 4, I apply Pesetsky & Torrego’s (2001; 2004; 2007) analysis of Case to NSLs (with special attention to Spanish),² suggesting that T (and not *v**) seems to act as a phase head in those languages –in particular, I contemplate the possibility that verb movement creates phase boundaries; finally, section 5 considers some consequences that are taken as parasitic on verb movement and concern the special status of subjects in Romance languages.

¹ Uriagereka (1999b) argues that TP behaves as a barrier/cycle in languages with rich inflectional systems. His proposal builds on the heavy/light (or, alternatively, hot/cold) distinction stemming from Huang’s (1982) work, and claims that TP undergoes (PHON) Transfer whenever a SPEC is created.

² Unless qualified, in what follows I will use the label ‘Spanish’ to refer to the variety spoken in the Iberian peninsula (for concreteness, Spain).

2. Phase Theory: Locality and Parameters

This section discusses Chomsky's (2000; 2001; 2004; 2005; 2007; to appear) *Phase Theory* in detail, addressing the validity of the different criteria to identify phases. I argue that none of them (with the exception of ϕ -feature valuation) offers conclusive evidence for the special status of phases.

2.1. Phases *qua* Numerations

One of the central theoretical issues being investigated within minimalism is whether (and how) access to the Lexicon must be restricted. Within minimalism, two ways to link the Lexicon and Narrow Syntax have been considered: in a direct fashion, or through an intermediate step whereby a bunch of LIs are pre-selected.

Mainly due to economy considerations, Chomsky (1995b) introduces the notion of *Lexical Array* (LA), understood as a pre-syntactic domain storing LIs to enter a given derivation.³ Thus, to derive an expression like (2b), (2a) is taken as its previous step:

- (2)
a. {The₂, book₁, C₁, John₁, T₁, put₁, on₁, v*₁, shelf₁}
b. John put the book on the shelf.

Considering questions of computational load in more detail, Chomsky (2000: 100-106) restricts the access to LAs so that only a given subpart is placed in 'active memory:' a *phase*. The important question that emerges at this point is how those subarrays are selected.

Chomsky (2000; 2001; 2004; 2005; 2007; to appear) gives both conceptual and interface motivation endorsing the idea that phases are CP and *v**P: conceptually, phases should be small subarrays (so that computational load is avoided), whereas,

³ Strictly speaking, a LA contains tokens of LIs. If more than one token of the same type is selected, as in (2a), an LA is called *Numeration* (Num).

interface-wise, phases should manifest easily detectable semantic and phonetic properties indicating a sort of independence:⁴

[P]hases should have a natural characterization in terms of IC: they should be semantically and phonologically coherent and independent. At SEM, v^* P and CP (but not TP) are propositional constructions: v^* P has full argument structure and CP is the minimal construction that includes tense and event structure and (at the matrix, at least) force. At PHON, these categories are relatively isolable (in clefts, VP-movement, etc.).
[from Chomsky 2004: 124]

In more recent work, though, Chomsky (2004; 2005; 2007; to appear) has argued that the most important criterion in determining phases is not related to either LAs or interface properties, but to the Case/agreement systems (the A-systems). In particular, reliance on the latter make phases follow, since deletion of ϕ -features force phase boundaries to emerge.

As discussed elsewhere (Chomsky 2001), the size of phases is in part determined by uninterpretable features. Such features are a striking phenomenon of language that was not recognized to be significant, or even particularly noticed, prior to Vergnaud's original ideas about the role of structural Case [...] These observations provide further support for the conclusion that v^* P and CP are phases, the locus of determination of structural Case and agreement for object and subject.
[from Chomsky to appear: 21]

Notice that this twist in the conception of phases squares not only with the revolutionary impact of Vergnaud's ideas, but also with the A/A-bar distinction: only A-operations take place within cycle boundaries (but see Boeckx 2006b for some qualifications). Importantly, Chomsky (2004; 2007; to appear) no longer emphasizes the role of LAs, but that of C and v^* , from which everything is derived (to put it in Richards's 2006 terms, phases are detected by 'all-powerful phase heads'), especially so Case.⁵ Plausibly, the shift is intended to avoid semantic characterizations of phasehood, like that invoking "propositionality" or "convergence" (see Chomsky 2000), which are admittedly murky.

⁴ See Fortuny (2007), Mayr (2005; 2006a), Richards (2004; 2006a), and Uriagereka (1999a; 1999b) for much relevant discussion.

⁵ Consequently, it is tempting to take this idea to support Abels' (2003) claim that P is a phase head too, under the reasonable assumption that P is responsible (like v^* and C) for Case checking. See section 3.

According to Chomsky (2001; 2004; 2007; to appear), computation proceeds *phase by phase*, with recursive access to LAs or just identification of a phase head –a choice that ultimately depends on C and v^* being the source of phasehood. Once completed, a phase is handed over to the interfaces by a Transfer operation:

(3) **TRANSFER**

Transfer hands D[erivation]-NS over to [PHON] and [SEM]

[from Chomsky 2004: 107]

Chomsky (2004) addresses the question of what portion of the phase must be transferred, noting two options: in root cases, Transfer spells-out the phase in full, but in non-root circumstances, only the ‘complement domain’ is cashed out. Notice, thus, that phase domains are similar to those Chomsky (1993a) already investigated for X-bar theory: as depicted in (4), ‘complement’ and ‘edge’ are the phasal counterparts of ‘complement’ and ‘residue’ of Chomsky (1993a):

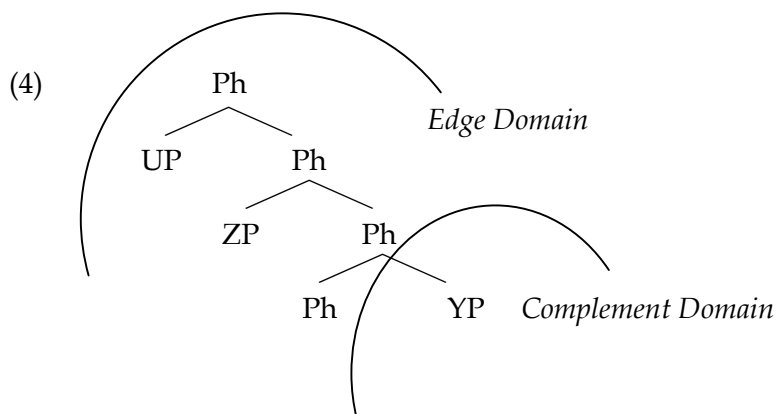

For optimal computation under (3), Chomsky (2000; 2001) proposes a *Phase Impenetrability Condition* (PIC), a constraint which forces the system to forget about transferred chunks, thus reducing computational burden and yielding the sole trace of cyclicity within minimalism (see Abels 2003, Boeckx 2003a; 2007, and Lasnik 2006):

(5) **PHASE IMPENETRABILITY CONDITION (PIC)**

The domain of H [the head of a strong phase] is not accessible to operations at ZP [the next strong phase]; only H and its edge are accessible to such operations

[from Chomsky 2001: 14]

Once a phase is shipped to the interfaces by Transfer, the next phase starts, and even if the previous phase head is still visible (it always is, since it belongs to its edge; see 4 above) it becomes computationally inert. Let us formalize this as (6):

(6) **PHASE INERTNESS**

The head of a phase is “inert” after the phase is completed, triggering no further operations

[from Chomsky 2000: 107]

The PIC is, needless to say, a stipulation, but a reasonable one if the idea that Narrow Syntax and SEM/PHON components talk to each other is entertained (no matter when, nor how many times), a non-controversial hypothesis ever since Chomsky & Lasnik’s (1977) “Y-Model,” or any model where syntactic information is cashed out to the interpretive components (see chapter 1).

Under the PIC, successive cyclic movement is forced to proceed, as just said, *phase by phase*, or, more precisely, *edge by edge*, much like in the *Barriers* system moved elements had to stop at Spec-C and Spec-V. Therefore, movement must target those positions (in a punctuated fashion; see Abels 2003), but nothing precludes passing through others (see Boeckx 2003a; 2007, and Chomsky to appear).

One technical observation with respect to the PIC is in order before going on. Note that, as the PIC stands, T could in principle probe into the complement domain of v^*P : it is only C (=Z in 7), the phase head, which cannot.

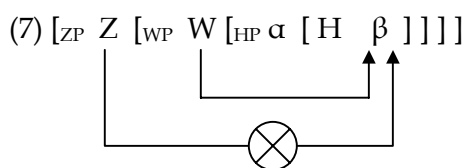

As we will see shortly, the possibility for T to reach β in (7) is tacitly barred in Chomsky (2007; to appear), where T can no longer act as a Probe (only phase heads can).⁶

On more general grounds, Chomsky (2000; 2001; 2004; 2007; to appear) seems to aim at relaxing Epstein et al.'s (1998) radical derivational approach, by taking operations to occur simultaneously within a phase: computation then 'waits' until the phase level is reached and operations take place chaotically within a phase (with no ordering; see Chomsky 2007), a scenario that minimally departs from a more dynamic system, like Epstein et al.'s (1998) or Epstein & Seely's (2002), where every single application of Merge is followed by Transfer (see chapter 1).

2.2. Phases *qua* Phase Heads

In the previous section we considered the original criterion to define phases, which was dependent on the existence of LAs and the relation between the Lexicon and Narrow Syntax (see Chomsky 2000; 2001). This perspective has been recently abandoned for a view whereby phases are signalled by tracking down phase heads (see Chomsky 2004; 2007; to appear): C and v^* .⁷ Let us therefore focus on the phase heads themselves, and to Chomsky's progressive strengthening of their leading role.

Contrary to the first formulations of *Phase Theory* (see Chomsky 2000; 2001), where structural Case was assigned by T and v^* , Chomsky (2004; to appear) considers the possibility that C and v^* constitute the locus of agreement features –in fact, all relevant computational features would belong to phase heads, and then spread to other heads.⁸

⁶ This is so under Chomsky's (2001) PIC definition, given in (5), which is different from the one in Chomsky (2000). Richards (2006a) compares both versions of PIC (PIC₁ and PIC₂), with interesting consequences for *Phase Sliding*. See section 3.

⁷ The question that arises here, as Juan Uriagereka observes, is *how* –and even more importantly, *where*– C and v^* are 'tracked down.' Is there any computational space to locate them? Chomsky (2007; to appear) seems to assume that there is a something similar to LAs, or, at least, that C and v^* are not alone. This much, I think, is needed, for otherways certain operations (say, the process of inheritance) could not be postulated. If so, then, LAs (which incarnate the main conceptual rationale for phases: economy!) are still there, but T and V play no relevant role, as they never act as Probes.

⁸ See Fortuny (2007) for recent explorations about 'spreading' of both φ and π -features.

As for the fact that T and V manifest ϕ -features, Chomsky (2007; to appear) claims that they do so just derivatively, as a consequence of a process of *inheritance* from C and v^* . According to Chomsky (to appear), inheritance also derives the already mentioned A/A-bar distinction: the Case/agreement systems drive A-movement, whereas what Chomsky (to appear) dubs *edge features* (EF) drive A-bar movement. Hence, we get (8), where H = a phase head and ZP its complement:

(8) ϕ -Inheritance from Phase-heads to non-Phase-heads

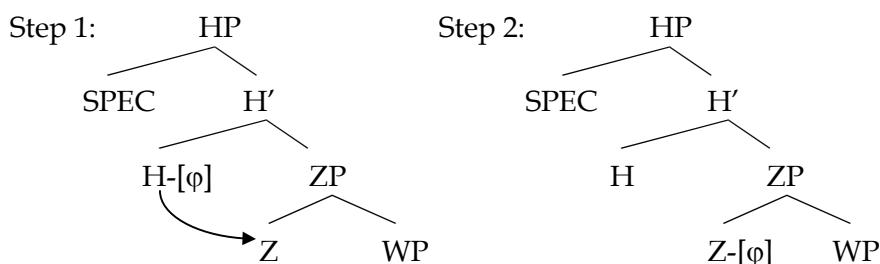

Before considering the mechanism of inheritance (see next section), we must clarify the notion of EF. In Chomsky (2000) a kind of EF was already assumed. By that time, however, EF was called “EPP feature” (or “P/OCC-feature;” see Chomsky 2000: 108, 144 fn.50; 2004: 112), drawing the parallelism from the *Principle P* of Chomsky (1981) and the *Extended Projection Principle* of Chomsky (1982) in that in both cases a specifier position is created. Viewed that way, phase heads, and phase heads alone, apart from their s-selection properties, can make use of EFs to capture A-bar- internal Merge to their specifiers. As defined in Chomsky (2000), EFs have two main properties: they are optional and exclusively related to internal Merge:⁹

Each CFC allows an extra Spec beyond its s-selection: for C, a raised *wh*-phrase; for T, the surface subject; for v , the phrase raised by object shift (OS). For T, the property of allowing an extra Spec is the Extended Projection Principle (EPP). By analogy, we can call the corresponding properties of C and v *EPP-features*, determining positions not force by the Projection Principle.

[from Chomsky 2000: 102]

The EPP-feature of T might be universal. For the phase heads C/ v , it varies parametrically among languages and if available is optional [...] *The fact that the EPP-feature when available is optional for C/v suggests that it is a property of the phase Ph [...] the EPP-feature must be satisfied by raising within Ph: pure Merge from outside Ph is barred.*

[from Chomsky 2000: 109 –emphasis added, AJG]

⁹ The only exception to this is the merger of expletives (see Chomsky 2004: 114), which are introduced by external Merge according to Chomsky.

The last paragraph is extremely relevant for what was explored in Gallego (2005). Right after it, Chomsky (2000) proposes the next correlation, crucial for defining phase heads (at that time).

(9) PHASE HEAD - EF CORRELATION

The head H of a phase Ph may be assigned an [EF]

[from Chomsky 2000: 109]

Notice that there is a non-trivial difference between EFs as understood before and after Chomsky (2007; to appear): before, they were taken as a prerogative of phase heads (and of T as well, at least in English) to trigger A-bar movement, whereas afterwards they are *a property of all LIs*. That is, after Chomsky (2007; to appear), EFs are the simplest way to for an LI to say ‘I can be manipulated by Merge.’

Some technical clarifications are in order. As observed by Boeckx (2003a; 2006b; 2007), there is ample empirical evidence (see Lasnik 1999a; 2001a; 2003a) that the classical type of EF cannot be understood as involving feature checking in any plausible way, being just a ‘specifier requirement,’ or, more accurately, a ‘Merge-requirement’ (if ‘specifier’ is an alias of ‘complement;’ see Chomsky 2007; to appear). Following Boeckx (2006b), one might refer to this variety of EF as “*epp*,” reserving the label “*EPP*” for the necessity for T’s SPEC to be filled in (the original EPP).¹⁰ A distinction like the one in (10), then, can be established, if only for operative reasons:

(10) EPP

EPP₁ (*epp*): allows LIs to undergo Merge

EPP₂ (*EPP*): requires SPEC-T to be filled in

Remember this: the EPP subtypes in (10) *do not* involve any *feature checking* (*pace* Boeckx’s 2006b analysis of EPP₂, which I come back to in chapter 3): they are just a way to encode that LIs can undergo Merge.

¹⁰ In Gallego (2005) I speculated that T requires its SPEC to be filled in for s-selectional matters: if T is a species of P (as Pesetsky & Torrego 2007 plausibly argue), then it makes sense that T be birrelational, as Ps are (see Hale & Keyser 1998). Logically, this entails that the EPP is universal, a controversial issue (see Alexiadou & Anagnostopoulou 1998; 2001).

At this point, the following question arises: is there any other subtype of EPP? The literature is replete with evidence for one type of internal Merge which, reportedly, involves feature checking: for Chomsky (2000; 2001; 2004; 2007; to appear) this is just another instance of EF satisfaction, but Rizzi (1997; 2004; 2006), and much work within the cartographic approach, entertains the idea that there are “criterial features,” that is, purely interpretive features which are spreaded along the *Left Periphery* of the clause, triggering A-bar (i.e., operator-variable) movements. Following Fortuny (2007), I will refer to Rizzi’s (1997; 2004; 2006) criterial features as “ π -features.”

If this latter subtype of EPP is incorporated into the picture, (10) should be qualified as shown in (11):

(11) **EPP**

EPP₁ (epp): allows LIs to undergo Merge

EPP₂ (EPP): requires SPEC-T to be filled in

EPP₃ (π): creates operator-variable chains

I believe (11) eliminates an undesired and tacit consequence of Chomsky’s (2007; to appear) system, which, as it stands, relates both A (theta/ θ) and A-bar (operator/ π) properties to EFs (if Chomsky’s EFs are the trigger for merger operations, then EFs are related to both A and A-bar properties). A more plausible move to disentangle these notions would be to capitalize either on particular features (Hornstein’s 2001 θ -features and Rizzi’s 1997; 2004; 2006; to appear criterial/ π features) or on particular operations. The latter option, as a matter of fact, follows at once from Chomsky’s (2004) insightful observation that the two types of semantics (deep and surface / theta and discourse oriented) go hand in hand with the two varieties of Merge. From this perspective, one needs not assume the existence of θ and π -features: the former can be recast by a configurational approach to argument structure along the lines of Hale & Keyser (2002), whereas the latter may be a side-effect of non-trivial chain creation, thus being configurational too, as Rizzi’s (1997; 2004; 2006; to appear) *Left Periphery* is.^{11 12}

¹¹ An obvious problem for this thesis comes from the fact that the A-systems also involve non-trivial chains –in, for instance, raising of both object and subjects to Case checking positions (see Boeckx 2006b and Lasnik 1999a; 2001a; 2002; 2003a). To get around this problem, one might

In what follows, I will assume so, taking A and A-bar properties to derive from configurations created by external Merge and internal Merge respectively. The only truly featural residue of these systems (in particular, of A-systems) is, as Juan Uriagereka observes, ϕ -features, which are taken care of by (long-distance) Agree, not Merge. Hence, I assume that any application of internal Merge be a potential candidate to yield an operator-variable (A-bar) chain –this will not be the case in the intermediate steps of successive cyclic movement, but it will eventually be.

Accordingly, I take it that π -features do not have any computational role whatsoever (in terms of Agree, surface semantics, intervention effects, etc.). Contrary to the possibility for argument structure to be a consequence of feature checking (but see Bošković & Takahashi 1998 and Hornstein 2001 for interesting explorations), the idea that discourse oriented semantics is triggered by dedicated semantic features (e.g., [topic], [interrogative], [focus], [relative], and so on) is customary and widely entertained. As just said, I will not adopt this view here, for reasons that I want to minimally clarify.

To begin with, the computational role of π -features is not all that clear. It is an robust empirical fact that criterial morphology exist, not only in wh-phrases, but also in more exotic languages, like Gungbe or Japanese, which readily manifest focus/topic morphemes (see Aboh 1998; 2004 and Miyagawa 2004; 2005):

- (12) ... do Kofi *ya* gankpa me we kponin le si I do. (Gungbe)
... that Kofi Top prison in Foc policemen PL shut him there
'... that policemen shut Kofi in prison'

[from Rizzi 2004: 238]

explore the possibility that such movements also have an A-bar nature, involving discourse-semantic effects, as Chomsky (2001: 33) argues. See below.

¹² One caveat is in order. Rizzi's (1997; 2004; 2006) approach to the *Left Periphery* can be said to be configurational (SPEC-H configurations must be created for Criteria satisfaction), but it is no less true that dedicated-feature checking is involved. If π -features are not involved in creation of peripheral configurations, then it follows that no relativized minimality effects should arise, as Chomsky (2005) speculates.

(13)

a. Taroo-wa HON-o katta. (Japanese)

Taro-TOP book-ACC bought

'Taro bought a book'

b. TAROO-*mo* hon-o katta. (Japanese)

Taro-also book-ACC bought

'Taro also bought a book'

[from Miyagawa 2005: 5]

There is, thus, no doubt about the existence of criterial morphemes. What is way more intricate is to decide whether those features fit in a Probe-Goal framework such as Chomsky's (2000; 2001). The problem is not new. Ever since Chomsky (1995b), it was not obvious how to motivate *wh*-movement on interface grounds: in what respect is *wh*-morphology uninterpretable? The same question can be asked for [topic] and [focus] features, but the result is more cumbersome, since these are purely semantic notions, hence interpretable by definition.

Consider *wh*-movement, for which Chomsky (2000: 107, 128) had to assume that "wh-phrase[s] ha[ve] an uninterpretable feature [wh] analogous to structural Case for nouns, which requires it to move to its final position in an appropriate C [...] the wh-phrase is active until [wh] is checked and deleted." In Chomsky (2001: 6), though, these ideas are dispensed with, adducing that, *wh*-movement aside, "postulation of [criterial] features is much more stipulative." Chomsky (to appear) represents the last stage of this elimination-of-criterial-features process: there is no checking proper going on –EFs do the job:¹³

¹³ Rizzi (2006) himself considers the possibility that all peripheral operations are triggered by a unique feature (something like Chomsky's to appear EF), but he discards that possibility on empirical grounds:

One could envisage the possibility that there is only one non-specific formal A'-feature, and the nature of the particular A'-chain is determined only when the moved phrase reaches a criterial head. Evidence against this hypothesis is provided by the fact that intermediate positions give rise to selective effects: e.g., embedded I to C movement in Belfast English is only triggered in questions [...] not in topicalization or other constructions in which the criterial head does not trigger I to C movement. [from Rizzi 2006: 126 fn.2]

What holds for *wh*-movement should extend to *A'*-movement generally. Suppose that the [EF] of the phase head is indiscriminate: it can seek any goal in its domain, with restrictions [...] determined by other factors [...] Take, say, Topicalization of DP. EF of a phase head PH can seek any DP in the phase and raise it to SPEC-PH. There are no intervention effects, unless we assume that phrases that are to be topicalized have some special mark. That seems superfluous even if feasible, particularly if we adopt Rizzi's approach to the left periphery: what is raised is identified as a topic by the final position it reaches, and any extra specification is redundant. The same should be true for other forms of *A'*-movement. We need not postulate an uninterpretable feature that induces movement.

[from Chomsky to appear: 18]

To put it in provocative terms, it is all too easy to pose a fill-SPEC requirement in order to capture semantic effects, but this does not constitute an explanation, it simply redescribes what must be explained. I have no objection to the idea (implicit in Chomsky's reasoning) that π -morphology exists, but it is necessarily interpretable, which poses a problem for 'activity:' features such as [topic] or [focus] cannot be said to have a lifespan, and they can hardly be assumed to give rise to match and intervention effects.¹⁴

In sum, I will dispense with the idea that π -features have a computational role, and, if I happen to mention them, it will be for merely descriptive purposes: for me, creation of operator-variable chains does not require features, but internal Merge, an idea that carries over to successive cyclic movement, which, following Boeckx's (2003a; 2007) revamping of Takahashi's (1994) *Form Chain*, I take to proceed through short steps "not in order to check some feature in intermediate sites, but simply to the requirement that steps be local."^{15 16} I hope the reader is able to go beyond the technical debate and

¹⁴ Chomsky (to appear), in fact, goes on to argue that:

Further elaboration depends on how the relevant structures are to be analyzed properly. To mention a few possibilities, suppose that the moved phrase is labeled by an interpretable interrogative *wh*-feature. Then it will have to reach the right position in the left periphery for interpretation, or be associated with such a position by some other operation. Otherwise the expression may converge, but will be interpreted as deviant at the C-I interface. A *wh*-phrase lacking the interpretable interrogative feature, or an empty operator, will yield a structure that converges but will again have no interpretation.[from Chomsky to appear: 18]

¹⁵ Rizzi (2006: 110) assumes that intermediate steps are morphologically triggered too, but the specific solution he offers is not transparent (more so than true criterial features). Rizzi (2006) argues that there are formal, uninterpretable, counterparts of criterial features along the movement path.

¹⁶ Ideally, the analysis should be extended to Quantifier Raising, where no dedicated feature appears to be needed to trigger the operation (see Fox 2000, Hornstein 1995; 1999, and Kitahara 1992; 1996).

realize that my goal is to assume as little as possible within Chomsky's (2000; 2001; 2004; to appear) Probe-Goal framework, strictly sticking to the SMT and to purely formal features: Case and agreement.

Significantly, it appears to be empirically true that discourse semantic effects (or, to put it in Rizzi's terms, criteria satisfaction) have a species of "freezing" effect on syntactic objects, analogous to the one witnessed in the A-systems (see chapter 1). This is puzzling if π -features are activity-proof (that is, if they cannot be 'switched off'). Rizzi (2006) formulates the next constraint to capture the facts:

(14) **CRITERIAL FREEZING (non-final version)**

A phrase meeting a criterion is frozen in place

[from Rizzi 2006: 112]

Although I will not entertain Rizzi's (2006) technical implementation of Criterial Freezing, I will accept its consequences. To be precise, I will assume that whenever a syntactic object in a phase edge receives an interpretation (see Chomsky 2001), it becomes opaque. I will come back to Rizzi's (2006) Criterial Freezing in chapter 4, when I address sub-extraction.

Note that nothing has been said about agreement processes so far, surprisingly so because these are typically subsumed within the A-systems (see Chomsky & Lasnik 1995). However, this scenario falls into place if agreement (or 'feature checking' more generally) involves features, not configurations, as discussed in chapter 1.

Having considered the A/A-bar distinction and the bearing of EFs, we can go back to the main discussion. The question that must be addressed is what is about phases and phase heads that makes them special. The recent literature has attributed them the following empirical properties:

(15) **EVIDENCE FOR PHASEHOOD**

- a. Merge-over-Move principle (see Chomsky 2000)
- b. Reconstruction effects (see Fox 2000 and Legate 2003)
- c. Parasitic gap licensing (see Nissenbaum 2000)
- d. Successive cyclicity (see Abels 2003, Boeckx 2007, and Chomsky 2000; to appear)
- e. SEM effects at edges (see Chomsky 2001 and Uriagereka 2002b)
- f. SEM and PHON independence (see Abels 2003, Chomsky 2000; 2001, Matushansky 2003, and Richards 2006c)
- g. Valuation of uninterpretable morphology (see Chomsky 2001; to appear and Pesetsky & Torrego 2001; 2004)
- h. Linearization (see Fox & Pesetsky 2005 and Richards 2004; 2006b)
- i. Stranding (see Abels 2003 and Chomsky 2001)
- j. CED effects (see Chomsky to appear and Uriagereka 1999a)
- k. Featural opacity (see Abels 2003 and Fortuny 2007)

Some of these aspects will be addressed later on (I defer discussion of Chomsky's to appear analysis of CED effects and featural opacity to chapter 4), whereas others (parasitic gap licensing and linearization) are not crucial for my purposes.

Among the arguments to reinforce phases listed in (15), some were rapidly shown to be problematic, such as the Merge-over-Move principle (see Boeckx 2006b, Boeckx & Grohmann 2007, Hornstein 2001, and Castillo et al. 1999 for arguments against it). The next three phenomena (reconstruction effects, parasitic gap formation, and successive cyclicity) can be clustered as locality issues in connection with the PIC: due to cyclic Transfer, transphasal movements are forced to target phase edges, in a punctuated fashion –targeting some positions and bypassing others (see Abels 2003).

Tacit in this discussion (as in the PIC) is the idea that only the edges provide an adequate landing site for operator/quantificational (i.e., A-bar) movement (see Butler 2006, Chomsky to appear and Pesetsky 2007), A movement targeting non-phasal landing sites (SPEC-T and SPEC-V), as indicated in (16):

(20)

- a. It is [_{CP} C PRO to go home (every evening)]_i that Johns prefers t_i
 b. *It is [_{TP} t_j T to t_j go home (every evening)]_i that Johns_j seems t_i

Chomsky (2000; 2001) takes the asymmetry in (20) to indicate a difference in shape: control infinitivals are CPs, whereas raising ones are bare TPs. There is much discussion about this analysis (see Hornstein 2003 and Wurmbrand 2001; 2005; 2007), but even under Chomsky's (2007; to appear) most recent formulations, it appears to be problematic: why should T project in raising and ECM contexts if the only role of this head is to inherit features from C? If there is no C, then there should be no T either.

But regardless of the control/raising distinction, phonetic isolability of phases is not restrictive enough, since we know that more syntactic objects have been reported to be isolable.²⁰ Of course, most of those objects have been identified as phases themselves (*v**P by Chomsky 2000, DPs by Svenonius 2004, and PPs by Abels 2003). The only exception is, intriguingly, TP, which has only been argued to be isolable in so-called Right Node Raising (see Abels 2003 and Bošković 2002):

(21) John believes and Peter claims that –[_{TP} Mary will get the job]

[from Abels 2003: 63]

A second problem for phonetic independence, as emphasized by Boeckx & Grohmann (2007), comes from the fact that phases proper are not isolable under Transfer: note that 'complement' and 'edge' are spelled-out (i.e., transferred to PHON) at different times.²¹ As it turns out, this is a problem that also affects semantics: the full argument structure of transitive *v** is not sent to PHON as a unit, but chunked down instead.²² Furthermore, semantic isolability is an obscure empirical notion, not only

²⁰ Think of any case of DP or PP topicalization.

²¹ Chomsky (2001) gets around this by arguing that a phase₁ (*v**P) is evaluated at the next phase, phase₂ (CP).

²² In principle, the same logic as before could be invoked: all we need is for full argument structure (of *v**P) to be evaluated in CP.

In chapter 4 I explore the possibility that the External Argument (EA) be generated below the phase head *v**, going back to a formulation more in the spirit of the *VP-Internal Subject Hypothesis* (see Hale & Keyser 1993, Kitagawa 1986, Koopman & Sportiche 1991, among others). If that is tenable, then the transferred-to-SEM part contains the entire argumental configuration.

because it is not entirely clear what effects “propositionality” has on syntactic grounds (if it has at all, see Hinzen 2006 and Moro 2006): in what sense is are v^* Ps (transitives) more complete or propositional than v Ps (unaccusatives)?

There is a flipside to phonetic isolability of phases: non-phases should not be cleftable (or, alternatively, phase heads should not strandedable). This idea has also been refuted in the literature. In particular, Abels (2003) shows that phase heads cannot be stranded due to a more general constraint barring vacuous Merge (a violation of Last Resort). Since movement of, say, VP requires targeting SPEC- v^* (not necessarily because of the PIC), VP merges with v^* twice without any feature checking taking place. I will assume this step to be barred by anti-locality, in Abels’s (2003) sense – consequently, movement is short indeed (as per Takahashi’s 1994 *Form Chain*), but not ‘too short.’

Two issues remain: valuation of ϕ -features (15g) and CED effects arising at phase edges (15j). I will assess (and eventually diverge from) Chomsky’s (to appear) analysis of CED effects in chapter 4. At present I want to concentrate on valuation, and go back Chomsky’s (to appear) inheritance.

2.3. Inheritance as Feature Sharing

In this section I turn attention to the operation of inheritance put forward in Chomsky (to appear). As we saw, Chomsky (to appear) claims that all formal features are generated in phase heads, C and v^* , from where they are downloaded to T and V respectively. This was depicted in (8), repeated here for convenience:

For similar ideas, I refer the reader to unpublished work by Clemens Mayr (see Mayr 2006b; 2007).

(22) φ -Inheritance from phase-heads to non-phase-heads

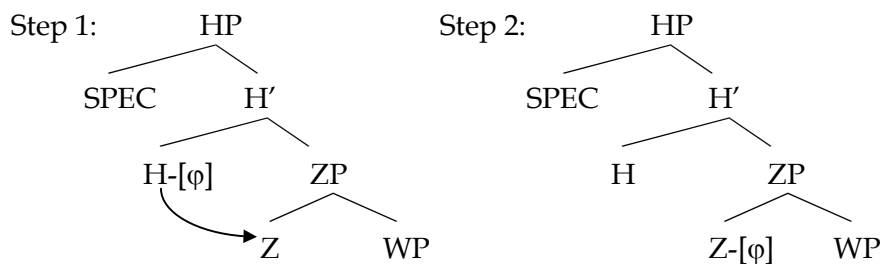

As noted by Chomsky (to appear: 10), a first worrisome aspect about inheritance is that it appears to violate principles of optimal computation such as the NTC. Chomsky (to appear), though, avoids this loophole by arguing that inheritance conforms to the SMT in order to yield the A/A-bar split, a cut with consequences at the C-I interface. However plausible, this idea might turn out to be, the last section showed that there are grounds to be skeptical about this: A and A-bar systems appear to be not entirely feature motivated.²³

Chomsky (2007) provides a different rationale for the process in (22) by adopting Richards' (2007) observation that inheritance of φ -features is forced by the PIC: if deletion of uninterpretable morphology is parasitic on Transfer (see Chomsky 2001), φ -features *must* be downloaded to the complement domain of phase heads for them to be deleted –were they to remain in C and v^* , and it would be impossible to distinguish them from interpretable ones at subsequent derivational stages.

Chomsky's (2007) point is well-taken, but it rests on the assumption that deletion can only operate through Transfer, which, in turn, implies that uninterpretable features must end up within the complement domain of phase heads:

²³ Remember that there are two featural candidates to be related to what is typically referred to as A-systems: θ -features and φ -features –such is, in brief, the intuition behind the GB notion of “L-Relatedness.” As argued above, I will not assume the existence of θ -features (they are a side-effect of external Merge), so only φ -features remain as truly L-Related (A) features.

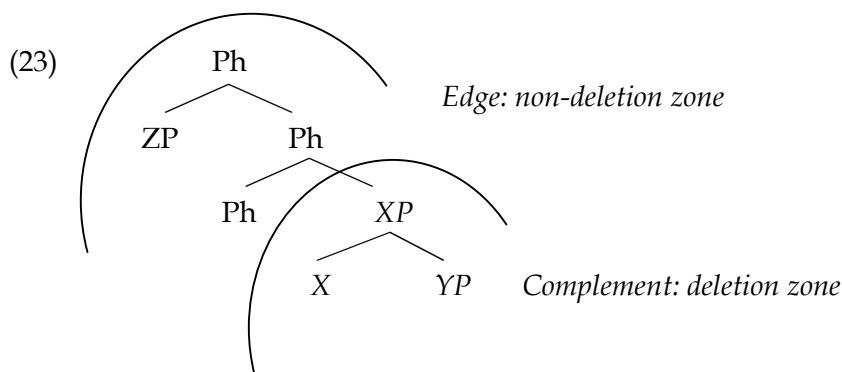

Here I would like to follow an alternative proposal, and argue, in line with Pesetsky & Torrego (2001; 2004), that deletion of uninterpretable morphology is merely phase bounded, with no need to make subtler distinctions such as the complement/edge one. I will therefore endorse (24), which is obviously related to the *Phase Condition* and the Phase-Level Memory of chapter 1:

(24) **TIMING OF DELETION OF UNINTERPRETABLE FEATURES**

An uninterpretable feature uF marked for deletion within a completed phase $[Ph]$ is deleted the moment a new head $[H]$ is merged to $[Ph]$

[from Pesetsky & Torrego 2004: 516]

The second worrisome aspect of inheritance is that it is a new operation, different from Merge and Agree, which poses conceptual concerns. In this respect, Chomsky (2007: 19 fn. 26) points out that inheritance is not much different from regular Probe-Goal dependencies: like these, inheritance modifies the featural endowment of syntactic objects. I will take this possibility seriously, regarding inheritance as an instance of “feature sharing” (see Frampton & Gutmann 2000 and Pesetsky & Torrego 2004; 2006). Hence, I will take ϕ -features on T not to be literally inherited from C, but rather shared with it (see Boeckx 2003a: 86-87). If the same hypothesis is carried over to the v^*P phase, then what one expects is for all LIs within a phase to share the same featural endowment. Keep this idea in mind, since I will come back to it in the next section.

Just like inheritance can be reformulated in feature sharing terms, deletion of uninterpretable features does not necessarily require in and of itself the stiff scenario

envisaged by Chomsky in (23): if indeed there is something like a Phase-Level Memory, all we need is for the system to remember that some features were introduced within a phase unvalued: if the system can keep track of that, it can also plausibly know that they must be deleted after valuation by the end of the phase, without resorting to Transfer to do that. Actually, the fact that ϕ -features are sometimes spelled out in C, and not T, is evidence that they can remain there –and, under my perspective, that they *must*, for they are never downloaded to T, but shared with it.

In this section I have reviewed the main aspects of Chomsky's (2000; 2001; 2004; 2007; to appear) *Phase Theory*, considering the different criteria that have been adduced in defining phases. I have focused on head-based definitions of phases (see Chomsky 2004; 2005; 2007; to appear), and, consequently, on the properties that phase heads have been attributed in the literature (e.g., successive cyclicity, reconstruction, PHON and SEM independence, etc.). I have addressed in passing what Chomsky (to appear) calls EFs (previously, EPP/Peripheral/OCC features), arguing for a three-way distinction of the "EPP" that builds on Cedric Boeckx's work:

(25) **EPP**

EPP₁ (epp): allows LIs to undergo Merge

EPP₂ (EPP): requires SPEC-T to be filled in

EPP₃ (π): creates operator-variable chains

I have endorsed the EPP₁ as a general property of LIs (with no checking), and, more controversially, I have rejected the EPP₃ –the idea that cartographic morphology (i.e., Rizzi's 1997; 2004; 2006 criterial features) have a computational role. Complementarily, it has been assumed (*contra* Chomsky 2000; 2001; to appear) that the A vs. A-bar cut is parasitic not on θ vs. π -features, but on operations. The only features that can still be described as being A (i.e., L-related) are ϕ -features, which are handled by (long-distance) Agree, not Merge.

As the reader may easily calculate, this viewpoint has to assume that there is no A-movement proper, or, differently put, that each and every single application of internal Merge is predicted to potentially have a semantic (A-bar, operator-related) effect. This

hypothesis seems to be correct even in the most conspicuous cases of A-movement, subject and object raising in English. We already considered the case of object raising (see 19 above). Let us have a look at subject raising now. In this sense, I think the following datum, taken from Rosselló (2000) (who attributes the contrast to Levin & Rappaport 1995 and Kirsner 1973) shows that subject displacement has a semantic effect not only in Romance (see Rizzi 2006 and Uriagereka 2002b for ample discussion), but in English as well. In particular, the position of the DP *three men* in (26) is not anecdotal:

(26)

a. [CP C [TP *Three men*_i T [_v*P *v* remained [t_i in the room]]]]

b. [CP C [TP There T [_v*P *v* remained [*three men* in the room]]]]

[from Rosselló 2000: 109]

In Rosselló's (2000) words: "[26b] cannot be interpreted agentively, i.e., in the sense that three men decided to remain. In [26a], instead, two interpretations are available: both the merely quantificational interpretation ('There were three men left in the room') and the agentive one ('Three men stayed in the room')." English, as a matter of fact, is not an optimal language to test this because of the EPP₂, since one cannot tell whether subject raising has semantic effects unless the operation is optional in the first place, the would-be semantic effect being masked by the obligatoriness of the process.²⁴

One crucial question remains: having questioned most of the properties in (15), is there anything special to phase(head)s? The answer is affirmative if, as I advanced at chapter 1 and at the outset of this chapter, phases are crucial in establishing landmarks for uninterpretable morphology deletion. Such an idea was dubbed *Phase Condition*:

(27) PHASE CONDITION

Uninterpretable morphology is phase bounded

²⁴ Happily, Rosselló's (2000) observation is reinforced by Boeckx's (2006b) analysis of the EPP₂: if, as he argues, the movement requirement of the EPP reduces to [person] checking, then it makes sense for subject raising to have a semantic import, given that [person] is a pragmatic feature, being typically related to point of view (see Boeckx 2000a; 2006b and Uriagereka 1995a; 1995b; 2002b). See chapter 3.

I will take this idea to be on track throughout this dissertation, paying particular attention to Pesetsky & Torrego's (2004) hypothesis that uninterpretable morphology has a phase-based lifespan. The question, then, is what uninterpretable features must be deleted at the end of a phase. So far, we have focused on agreement features (Chomsky's ϕ -features), putting Case to the side.

3. The Nature of Case: Consequences for Merge and Clause Structure

This section discusses whether Case can be considered as an independent *bona fide* feature participating in Chomsky's (2000; 2001) Probe-Goal framework. I argue so in section 3.1., adopting Pesetsky & Torrego's (2001; 2004) hypothesis that Case is actually a misnomer for aspect/tense: that is, a property which is interpretable in verbs (and their extended projections –see below), but not in DPs, just like ϕ -features are interpretable in the latter, not the former. Section 3.2. concentrates on Pesetsky & Torrego's (2006) *Vehicle Requirement on Merge*, pursuing the thesis that LIs within a phase share certain features. In sections 3.3. and 3.4. I discuss and update Gallego's (2005) *Phase Sliding* and its consequences for barrierhood, as understood by Uriagereka (1999b).

3.1. Case as Tense/Aspect

Since the advent of the P&P framework, structural Case has played a key role in the development of syntactic theory, up to the point that it can be said to be the first step towards minimalism. In Chomsky's (2000; 2001; 2004; 2007; to appear) system, structural Case in nominals is valued and deleted as a side-effect of an Agree dependency between the ϕ -Probes located in C and v^* . Under that perspective, ϕ and Case are both sides of the same coin, in accordance with George & Kornfilt's (1981) thesis that structural Case is a reflex of agreement:

Structural Case is not a feature of the Probes (T, v), but it is assigned a value under agreement, then removed by Spell-out from the narrow syntax. The value assigned depends on the probe: nominative for T, accusative for v (alternatively ergative-absolutive, with different conditions). *Case itself is not matched, but deleted under matching of ϕ -features.* [from Chomsky 2001: 6 –emphasis added, AJG]

Consequently, the process of Case assignment in Chomsky’s (2000; 2001) system proceeds roughly as in (28), where the relevant steps are: Match, Valuation, and Case assignment proper. Notice this: no Case feature is ever part of the Probe-Goal process.

(28)

- a. [CP C [TP T_[φ] [_v*P You_[2.SG] v*_[φ] [VP love Mary_[3.SG]]]]] Step 1: φ-Match
 b. [CP C [TP T_[2.SG] [_v*P You_[2.SG] v*_[3.SG] [VP loves Mary_[3.SG]]]]] Step 2: φ-Valuation
 c. [CP C [TP T_[2.SG] [_v*P You_{NOM}[2.SG] v*_[3.SG] [VP loves Mary_{ACC}[3.SG]]]]] Step 3: Case

In Pesetsky & Torrego (2001), a suggestive alternative approach to Case checking is put forward, one that I will assume in this dissertation. In particular, these authors claim that what we call “Case” is actually an uninterpretable (i.e., ‘misplaced,’ as Boeckx 2002b; 2003b puts it) aspect/tense feature on D heads.^{25 26 27}

(29) THE NATURE OF STRUCTURAL CASE

Case is [uT] in D

[from Pesetsky & Torrego 2001: 361]

This departure from mainstream analyses (where agreement and Case are different names for the same phenomenon) nicely fits with Chomsky’s (2000; 2001) Probe-Goal framework, because both Case and φ-features find an appropriate feature-mate. In Pesetsky & Torrego’s (2001) system, unlike in Chomsky’s (2000; 2001), feature valuation is then always a one-to-one relation. The following quote makes this point clear:

²⁵ Case morphology would then be like, say, finding subjunctive or tense morphology in nouns.
²⁶ See Svenonius (2001; 2002a; 2002b) for related ideas about Case being ‘uninterpretable aspect.’
²⁷ Considering data from Greek, Iatridou (1993) provides an empirical argument that suggests agreement alone is not responsible for structural Case assignment. The relevant minimal pair is that in (i)-(ii): the higher verb assigns accusative to the embedded subject in (i), whereas in (ii) the embedded subject is assigned nominative. Crucially, in both sentences the embedded verb agrees with its subject:

- (i) Vlepo ton Kosta na tiganizi psaria. (Greek)
 see-1.SG DET Kosta-ACC fry-3.SG fish
 ‘I see Kostas fry fish’
 (ii) Elpizo o Kostas na tiganizi psaria. (Greek)
 hope-1.SG DET Kostas-NOM fry-3.SG fish
 ‘I hope Kostas fries fish’

[from Iatridou 1993: 176-177]

The important factor –Iatridou (1993) points out– appears to be tense: only (ii) can change its tense specification in the embedded clause

The MI/DbP framework does not view structural case as the uninterpretable counterpart of an otherwise interpretable feature. Instead, it is a *sui generis* feature with a special relation to the φ -features: it gets valued only as a by-product of φ -feature agreement. Thus, when unvalued φ -features of finite T probe, on this approach, and find a suitable goal –for example, a DP with a full set of φ -features– the unvalued case features of that DP gets valued as a kind of ‘bonus.’

[from Pesetsky & Torrego 2007: 16]

In Pesetsky & Torrego (2001) discussion is largely restricted to nominative Case, which is said to follow from T engaging Agree with the subject DP and valuing its T feature. This view is extended to accusative Case in Pesetsky & Torrego (2004), where a second T head (corresponding, roughly, to Kratzer’s 1996 “Voice” or de Miguel’s 1990 “Aspect;” see McDonald 2006 for recent discussion) is sandwiched between v^* P and VP.²⁸ Following Pesetsky & Torrego (2004) I will represent those T heads as T_S and T_O respectively. The clausal backbone is therefore as in (30):

(30) CLAUSE STRUCTURE

[_{CP} C [_{TP} T_{SUBJECT} [_{v^* P} EA v^* [_{TP} T_{OBJECT} [_{VP} V IA]]]]]]]

The picture is finally squared by taking prepositions to be a species of T heads (both of them being birrelational spatio-temporal predicates), thus accounting for why they are also Case assigners.

As the reader may recall, this last point is in line with Abels’s (2003) claim that prepositions are phase heads, an idea that goes back to pioneering work by Emonds (1985) and van Riemsdijk (1978), who related prepositions to C. For Abels (2003), however, P is a phase head because it obeys his *Stranding Generalization* –the ban against stranding phase heads. If PPs are phases, as Abels (2003) reasonably argues, the following descriptive generalization (in line with the *Phase Condition*) can be made:²⁹

(31) THE PHASE-CASE CORRELATION

Phases are Case checking domains

²⁸ Pesetsky & Torrego’s (2004) T_OP strongly resembles Chomsky’s (1991; 1993a) Agr_OP. For related ideas, see Johnson (1991), Lasnik (1999a; 2001a; 2003a), and, particularly, Koizumi (1995). For similar proposals within the realm of clitic doubling, see Torrego (1998a; 1999).

²⁹ The idea that PPs are phases is also present in McGinnis (2004) and Pylkkänen (2002), where high Applicatives are analyzed as phasal domains.

(31) is nothing but a different way of encoding Chomsky’s (2001; 2004; to appear) formal, semantics-less, characterization of phases as the locus of uninterpretable features. Chomsky (2000; 2001; 2004; 2005; 2007; to appear) takes agreement features to be the relevant uninterpretable morphology, while Pesetsky & Torrego (2001; 2004; 2007) concentrate on Case. I will embrace both ideas, assuming that all syntactic objects within a phase share Case and ϕ -features, as indicated in (32) (see next section for further refinements):

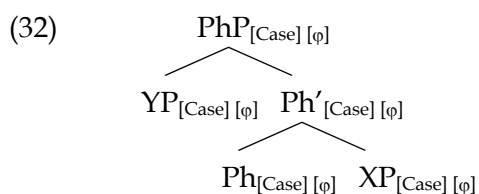

I believe this is a welcome result, for it strengthens the idea that functional categories within a phase form an abstract unit which Grimshaw (1991) called “extended projection” (see Boeckx 2006a). Thus, I will incorporate the category P into the Phase/Case systems:

(33) PHASAL EXTENDED PROJECTIONS

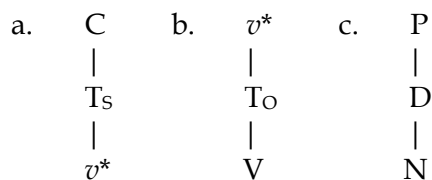

Grimshaw’s (1991) point was that lexical categories (N and V) were able to elongate themselves, giving rise to a fixed functional skeleton. Hence, C was seen as an extension of T_S and v^* , which would in turn be an extension of T_O and V. As for P, in chapter 4 we will see that the structure in (33c) can be complicated, with additional P heads above P –for the time being, this is enough.

Let us go back to Pesetsky & Torrego’s (2001; 2004; 2007) proposal. In chapter 1, I argued that features should be regarded as (un)valued attributes. If that view is to be maintained, we must find plausible values to Pesetsky & Torrego’s (2001; 2004) T/Case feature. I already made a suggestion in chapter 1 in this regard, which I sharpen here:

(34) CASE MORPHOLOGY

Feature	Value(s)
<i>Tense/Aspect/Case</i>	[nominative]
	[accusative]
	[oblique]

The box in (34) shows traditional assumptions about Case (see Boeckx 2003b and Chomsky 1986b for discussion).³⁰ From this point onwards, I will assume that the Probes T_S , T_O , and P (or T_{OBL}) bear the values shown in (34), and precisely in that order. I will assume that *nominative*, *accusative*, and *oblique* Cases are assigned by those functional heads, as indicated below:³¹

(35) CASE CONFIGURATIONS

a. *Nominative Case*

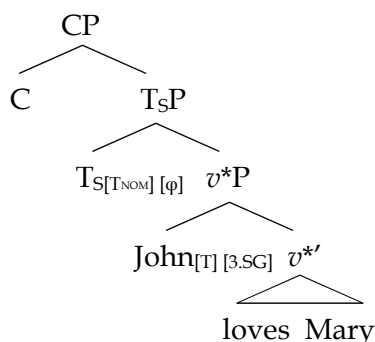

b. *Accusative Case*

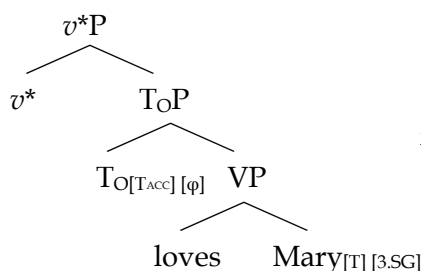

c. *Oblique Case*³²

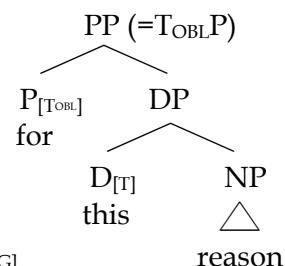

In the previous chapter I also mentioned one aspect that is crucial for Chomsky's (2000; 2001) assumptions on the Case/agreement systems: defectiveness. I did not

³⁰ Perhaps (i), which subsumes *nominative* and *accusative* as *structural*, is more accurate:

(i)

Feature	Value(s)
<i>Tense/Aspect/Case</i>	[structural] [inherent] [quirky]

³¹ I therefore assume (in the spirit of Chomsky 1986b: 193) that prepositions assign oblique Case. This hypothesis will become relevant in chapter 4, where, following Chomsky (1986a: 36), I will pursue the idea that oblique Case is relevant for blocking sub-extraction processes.

³² Pesetsky & Torrego (2004: 509-510) propose a somewhat different analysis for (non-clausal) PPs. According to them, P undergoes head movement from a TP projection sandwiched between DP and *nP*, a movement triggered by D's unvalued T feature. As the reader may see, I take it (although nothing crucially hinges on this, at least not at this point) that Ps undergo external Merge with the DP.

elaborate much on this notion, though I merely noted that some of Chomsky's (2000) CFC may be defective, lacking some of its features.

(36) **DEFECTIVENESS**

An LI is defective if it lacks some feature(s) of a given class

In Chomsky (2000; 2001), defectiveness reduces to Probes on T_S and v being unable to value their Goals. In the case of the verbal realm, defectiveness boils down to unaccusative and passive structures, where (a weak) v cannot value the Case feature of object DPs, which depends on T_S . In the case of T_S , defectiveness bars nominative Case assignment to subject DPs, which then depends on higher probes (T_S in the case of raising, T_O in the case of ECM).

In order to make things clear, consider the intricacies of defectiveness, say, in unaccusative structures –keeping things to Chomsky's (2000; 2001) system, where there are no Case features.

(37) *Case assignment in an unaccusative structure (Chomsky's Probe-Goal framework)*

- a. $[CP\ C\ [TP\ T_{comp[\phi]}\ [vP\ v_{def\ [\phi]}\ [left\ John_{[3.SG]}\]]\]]]$ Step 1: ✓ Match (v , $John$)
- b. $[CP\ C\ [TP\ T_{comp[\phi]}\ [vP\ v_{def\ [3.SG]}\ [left\ John_{[3.SG]}\]]\]]]$ Step 2: ✓ Valuation ($John$, v)
- c. $[CP\ C\ [TP\ T_{comp[\phi]}\ [vP\ v_{def\ [3.SG]}\ [left\ John_{[3.SG]}\]]\]]]$ Step 3: ✗ Case assignment (v , $John$)
→ $John$ remains 'active'
- d. $[CP\ C\ [TP\ T_{comp[\phi]}\ [vP\ v_{def\ [3.SG]}\ [left\ John_{[3.SG]}\]]\]]]$ Step 4: ✓ Match (T , $John$)
- e. $[CP\ C\ [TP\ T_{comp[3.SG]}\ [vP\ v_{def\ [3.SG]}\ [left\ John_{[3.SG]}\]]\]]]$ Step 5: ✓ Valuation ($John$, T)
- f. $[CP\ C\ [TP\ T_{comp[3.SG]}\ [vP\ v_{def\ [3.SG]}\ [left\ John_{NOM[3.SG]}\]]\]]]$ Step 6: ✓ Case Assignment (T , $John$)

With this summary as background, it is necessary to ask whether (and how) defectiveness can be recast within a system where agreement is not the flipside of Case. Pesetsky & Torrego (2007) address this very point, concentrating on raising structures, which they analyze as involving an embedded v^* whose T feature is unvalued –for them, this is what defectiveness amounts to and what subject raising follows from.

Importantly for their analysis to go through, they must assume that (un)interpretable features can come from the Lexicon both valued and unvalued: in the

case of T features, Pesetsky & Torrego (2007) argue that, though truly interpretable in T_S ,³³ they appear valued in the verb, therefore, T_S has to probe its domain in order to value its otherwise interpretable T feature: it first matches the subject DP, but since its T feature is also unvalued, T_S must probe again until v^* is matched. Consider the entire process of nominative Case assignment, depicted step by step in (38):

(38)

- a. $[_{CP} C [_{TP} T_{S[T]} [_{v^*P} EA_{[T]} v^*_{[T_{NOM}]} [_{VP} V IA]]]]$ Step 1: ✓ Match (T_S , EA)
 ✗ Valuation (EA, T_S)
- b. $[_{CP} C [_{TP} T_{S[T]} [_{v^*P} EA_{[T]} v^*_{[T_{NOM}]} [_{VP} V IA]]]]$ Step 2: ✓ Match (T_S , v^*)
- c. $[_{CP} C [_{TP} T_{S[T_{NOM}]} [_{v^*P} EA_{[T_{NOM}]} v^*_{[T_{NOM}]} [_{VP} V IA]]]]$ ✓ Valuation (T_S , EA, v^*)

Pesetsky & Torrego (2007) do not show how their system would work in the case of ECMs, but they do not need to: by assumption, embedded v^* would also bear an unvalued uninterpretable T feature, forcing subject raising.³⁴

Suppose Pesetsky & Torrego's (2007) reasoning is essentially correct. Let us add a slight twist and assume that, as far as Case is concerned, defectiveness is not related to v^* , but to T_S and T_O . If so, one could assume that raising (and ECM) structures have a T_S which either has unvalued T or, more radically, has no T feature at all. Both possibilities are shown in (39) for the raising case:

(39) *Defective T configuration*

- a. $[_{vP} v seem [_{TP} T_{Sdef[T]} [_{v^*P} EA_{[T]} v^*_{[T]} [_{VP} V IA]]]]$
- b. $[_{vP} v seem [_{TP} T_{Sdef} [_{v^*P} EA_{[T]} v^*_{[T]} [_{VP} V IA]]]]$

In the case of defective v^*P (i.e., vP), the same logic should apply: either T_O has an unvalued T or else T_O has not T feature at all.

³³ Pesetsky & Torrego (2007) do not extend the same logic to T_O (i.e., they do not argue that V bears the value for T_O 's T feature).

³⁴ What about v^* 's defectiveness –that is, what about unaccusative and passive structures? Presumably (but this is just a speculation, as Pesetsky & Torrego 2007 remain silent about the relation between T_O and V with respect to T features), V would lack the relevant value for its T feature –according to my assumptions, “ACC.”

(40) *Defective v configuration*

a. [_vP v [TP T_{Def} [T] [VP V IA]]]

b. [_vP v [TP T_{Def} [VP V IA]]]

A third possibility is that there is no T_{OP} projection in unaccusative and passive structures. That would certainly make sense, for T_O seems to play no role in mediating between the subevents embodied by *v** and V.³⁵ Be that as it may, I will assume the less drastic scenario: the one where T features are present in T heads, albeit in an unvalued fashion.³⁶ This is what we need to capture the facts, as I will argue in chapter 3.

Before concluding this section it is worth asking whether the outlined systems can be unified: that is, whether Chomsky’s (2000; 2001) and Pesetsky & Torrego’s (2001; 2004) proposals can collapse. I believe so, even though the details are somewhat difficult to sharpen. The intuitive idea should capitalize on the fact that both agreement and T/P heads are elements which ‘glue’ LIs together.

Consider (41), where the plural affix *-os* and the preposition *de* are used to join the noun *ministro* (Eng. *minister*) and the adjective *argentino* (Eng. *Argentinian*).

(41)

- | | | |
|--------------|--------------------------------------|-----------|
| a. Ministros | argentinos. | (Spanish) |
| | minister-MASC.PL argentinian-MASC.PL | |
| | ‘Argentinian ministers’ | |
| b. Ministros | de Argentina. | (Spanish) |
| | minister-MASC.PL of argentina | |
| | ‘Ministers of Argentina’ | |

³⁵ Pesetsky & Torrego (2004: 504-505) discard that T_{OP} is not projected where it does not seem to make any semantic contribution, like stative clauses (e.g., *Mary owns a car*). They assume T_{OP} does project in thoses cases, since accusative Case is assigned by stative predicates too.

³⁶ Ignacio Bosque (p.c.) informs me that the same could be said for mass nouns (e.g., *money, meat*, etc.), which have unvalued number. Actually, according to Ignacio Bosque, the number feature of mass nouns would be uninterpretable as well (he obviously relates number interpretability to the possibility of having a cardinal reading, if I interpret his words well). I do not subscribe the latter claim, but I agree that the number feature of mass nouns, if present, comes unvalued from the Lexicon. For the claim that number is interpretable in relational (non-predicative) adjectives, I refer the reader to Bosque (2002).

The parallelism in (41) calls for treating prepositions as an agreement of sorts. Granted, prepositions would be more than mere agreement (they would also contain T_{OBL} features), but the core idea I would like to put forward here is actually Torrego's (1995a; 1998a) insight: clitics and prepositions are a species of inflection. Note, furthermore, that prepositions block noun-adjective agreement, indicating that only one of these devices can be used to glue both LIs:^{37 38}

- (42) *Ministros* (**de*) *argentinos*. (Spanish)
 minister-MASC.PL of Argentinian-MASC.PL
 'Ministers of Argentinian'

From a diachronic perspective, the proposal is also sound, since, as is well-known, Romance prepositions started to emerge as inflectional morphology disappeared.

Within the generative tradition, the idea is not bizarre either: Kayne (1994; 2000) treats some elements as being a hybrid preposition/determiner/complementizer (see 43a), while Uriagereka (2002a) analyzes some prepositions as heads of agreement projections in his approach to possessive structures (see 43b):

³⁷ The present system does not preclude prepositional clusters (neither does Pesetsky & Torrego's 2001; 2004). All that matters is that the extra P elements convey a semantics of their own, making an interpretive contribution. Cases like (i), (ii), and (iii), taken Bosque (1997) illustrate this point.

- (i) Quitó los libros de la cama. (Spanish)
 remove-PAST-3.SG the books of the bed
 'He took the books from the bed'
- (ii) Quitó los libros de sobre la cama. (Spanish)
 remove-PAST-3.SG the books from above the bed
 'He took the books from above the bed'
- (iii) Quitó los libros de encima de la cama. (Spanish)
 remove-PAST-3.SG the books of over of the bed
 'He took the books from over the bed'

[from Bosque 1997: 140]

³⁸ As José M. Brucart (p.c.) observes, agreement across prepositions occurs in predicative structures like (i), which presumably involve a structure different from regular PPs (see Den Dikken 2006 and Uriagereka forthcoming for an analysis):

- (i) La estúpida de tu prima. (Spanish)
 the stupid-FEM.SG of your cousin-FEM.SG
 'The stupid of a cousin of yours'

(43)

a. $[_{DP} D \text{ La } [_{P/DP} \text{ voiture}_i [_{P/D'} P/D \text{ de } [_{TP} T \text{ Jean } t_i]]]]]$ (French)

the car of Jean

'Jean's car'

b. $[_{DP} D \text{ The } [_{AgrP} \text{ poor neighborhoods}_i [_{Agr'} Agr \text{ of } [_{SC} [_{DP} \text{ the city}] t_i]]]]]$

In this section I have sketched Pesetsky & Torrego's (2001; 2004) hypothesis that what we call Case is actually a 'misplaced' aspect/tense feature on D heads, reconsidering its impact on defectiveness/completeness. The idea is appealing at different levels, but perhaps especially so in that it supports the claim that all formal features potentially make some semantic contribution, in accordance with Brody's (1997) *Thesis of Radical Interpretation* (see Pesetsky & Torrego 2001; 2004 for discussion).

Technically, this system departs from Chomsky's (2000; 2001) in non-trivial respects because in the latter Case is not a feature in the intended sense: it cannot be matched, so it is not immediately obvious how it is assigned a value and deleted; more worryingly, it is not clear to me either how is it that Case is responsible for rendering syntactic objects 'active,' if Case itself is assigned after Agree takes place.

In what follows I want to explore a second important claim made by Pesetsky & Torrego (2001) –namely, that C also contains a T feature–, but, before going into that, exploring what the consequences of Pesetsky & Torrego's (2001; 2004) proposal are for phrase structure is in order.

3.2. Feature Sharing and Merge

Consider the clausal spine as it was depicted in (44):

(44) $[_{CP} C [_{TP} T_{SUBJECT} [_{v^*P} EA v^* [_{TP} T_{OBJECT} [_{VP} V IA]]]]]]]$

The first aspect worth highlighting about (44) is that it provides more symmetry than Chomsky's orthodox *Phase Theory*: in (44), both C and v^* select for T heads, the true locus of Case. Things being so, one could explore the possibility for ϕ -features to be downloaded from C and v^* to T_S and T_O respectively –yet again, in a more

symmetric way. That move, though coherent, slightly departs from the route I have already taken.

In chapter 1 I advanced that I would follow Boeckx (2002a) in taking phrase structure relations as involving feature sharing.^{39 40} Actually, as Cedric Boeckx (p.c.) observes, phrase structure in the sense of Chomsky (1970) is more context sensitive than standard Phrase Structure Grammar formulations: as (45) shows, X-bar algorithms have an Agree-like flavor to them, since all the dependents within a phrase have a property in common: their context is defined by X (via endocentricity):⁴¹

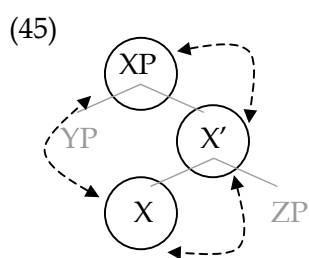

What are the features that can be shared? Throughout I will assume that only φ and T features can be shared within a given domain (i.e., phase/phrase), putting to the side purely interpretive (eboth π and θ) features.

In order to see how this system would work, take the v^*P . In my view, the φ -bundle should be shared by v^* , V, T_O , and the object DP (the IA), being valued only in the latter,⁴² more or less as indicated in (46):

$$(46) [v^*P \text{ John}_{[3.SG]} v^*_{[\varphi]} [TP \ T_{O[\varphi]} [VP \ \text{called}_{[\varphi]} \ \text{them}_{[2.PL]}]]]$$

³⁹ This is not forced by set theory: the elements in a set do not have to share any property –apart from being members of that set, of course.

⁴⁰ For similar proposals trying to motivate Merge, see Contreras & Masullo (2000).

⁴¹ Standard Phrase Structure Grammars can generate non-endocentric rules like (i) or (ii) (see Chomsky & Lasnik 1995), which are ruled out by X-bar Theory:

(i) $PP \rightarrow D \ NP$

(ii) $TP \rightarrow V \ CP$

⁴² Building on insights by Torrego (1998a), I tacitly assume that clitics play the role of object agreement. This does not mean that clitics are agreement morphemes analogous to the ones showing up in verbs: they are weak pronouns, so φ -features are interpretable on them.

Similarly, I assume that T features are shared. So, in the CP phase, the T feature should be shared by C (see next section for more on C's T), T_S, and the subject DP (the EA), being interpretable just in the second element.

(47) [_{CP} C_[T] [_{TP} T_{S[T_{NOM}]} [_{v*P} John_[T] . . .]]]

In sum, I do not endorse Chomsky's (to appear) conception of inheritance. In (46) and (47) features are not transferred, removed, or downloaded: they appear in different LIs, the main difference depending on whether they come from the Lexicon valued or not.

It is now reasonable to ask whether Merge and feature sharing are related. Chomsky (2000: 133-134) suggests in passing that Merge has an Agree-like nature: either α or β acts as a selector, and projects. Boeckx (2002a), aiming at unifying external Merge and internal Merge, proposes that whenever two LIs undergo Merge, one of their features must be matched and percolate up.

(48) The label K of $\{\alpha, \beta\}$ = The feature F shared in grouping $\{\alpha, \beta\}$

[from Boeckx 2002a: 21]

In the spirit of Boeckx's (2002a), Pesetsky & Torrego (2006) argue that Merge always requires feature sharing. As they put it, feature sharing is a *Vehicle Requirement on Merge*:

(49) **VEHICLE REQUIREMENT ON MERGE**

If α and β merge, some feature F of α must probe F on β

[from Pesetsky & Torrego 2006: 1]

Note that (49), as well as (48), does not entirely equal the operations Merge and Agree: all they say is that syntactic objects undergoing Merge must share some property, triggering Match. Since the discussions they go into will prove relevant for matters to which I return in chapter 4, let me offer a sample of Pesetsky & Torrego's (2006) *Vehicle Requirement on Merge* in the remainder of this section.

Building on previous work of their own (see Pesetsky & Torrego 2004; 2007), Pesetsky & Torrego (2006) consider the different complementation patterns displayed by verbs and nouns. The former, as Pesetsky & Torrego (2006) observe, allow DP complements, but not PPs:⁴³

(50)

- a. [_{v*P} Sue v* destroyed [_{DP} the city]]
- b. * [_{v*P} Sue v* destroyed [_{PP} [_P P of [_{DP} the city]]]]

In the case of clausal complements, for reasons that will be dealt with in the next section, Pesetsky & Torrego (2006) observe that verbs can take dependents with and without complementizer:

(51) *CP introduced by complementizer*

- a. [_{v*P} John v* said [_{CP} C that [_{TP} he would be late]]]
- b. [_{v*P} Mary v* desired [_{CP} C for [_{TP} Sue to win]]]

(52) *Complementizer-less CP*

- a. [_{v*P} John v* said [_{CP} C [_{TP} he would be late]]]
- b. [_{v*P} Mary v* desired [_{CP} C [_{TP} PRO to win]]]

Importantly, prepositions cannot precede complementizers:

(53) * [_{v*P} Mary v* said [_{PP} P of [_{CP} C that [_{TP} she would be late]]]]

The example in (53) is particularly interesting, given that some dialectal varieties of Spanish (dequeísta Spanish) do allow for similar dependents:

⁴³ According to Pesetsky & Torrego (2004), PPs cannot be direct dependents of V, so they analyze them as second objects. This includes PPs like *to John* in *Mary talked to John* or the so-called prepositional government objects of traditional grammar (e.g., *apply for a job*, *talk about linguistics*, *rely on bad arguments*, etc.; see Demonte 1991 and Simoni 2003). I will come back to this issue in chapter 4, where I consider whether these recycled second objects must actually be regarded as adjuncts or indirect dependents.

(54)

a. Pienso [CP C que los conozco poco]] (Standard Spanish)

think-1.SG that CL-them know-1.SG few

‘I think I do not know them well’

b. Pienso [PP P de [CP C que los conozco poco]] (Dequeísta Spanish)

think-1.SG of that CL-them know-1.SG few

‘I think of I do not know them well’

[from Demonte & Fernández-Soriano 2005: 1064]

Examples like those in (54) have been explained by invoking Case theory or the existence of a covert factive nominal introducing dequeísta CPs (something like *(el hecho) de que* – *(the fact) of that*). Ample empirical evidence, however, indicates that those accounts face independent problems (see Demonte & Fernández-Soriano 2002; 2005 and Picallo 2002).

In Demonte & Fernández-Soriano (2002; 2005) it is argued that the correct structure for (54b) is the one in (55):

(55)

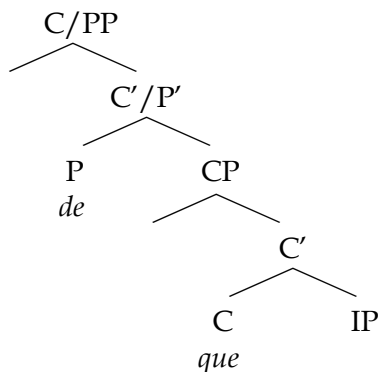

[from Demonte & Fernández-Soriano 2005: 1069]

As (55) shows, these CPs are analyzed as direct dependents of the verb, regardless of the preposition, an option that is at odds not only with (50), but also with the fact that prepositions typically appear before *que* in ungoverned domains (that is, in adjunct clauses):

(56)

- a. Germán llamó [PP P *para* [CP C *que* Diana viniese]] (Spanish)
 Germán call-PAST-3.SG for that Diana come-SUBJ-3.SG
 ‘Germán called so that Diana came’
- b. Germán llamó [PP P *por* [CP C *que* [TP Diana no había venido]]] (Spanish)
 Germán call-PAST-3.SG for that Diana not had-3.SG come
 ‘Germán called because Diana had not come’
- c. Germán llamó [PP P *aun* [CP *que* C [TP Diana no vino]]] (Spanish)
 Germán call-PAST-3.SG though that Diana not come-PAST-3.SG
 ‘Germán called although Diana did not come’

The flipside of all these verbal patterns is found in the realm of nouns, which systematically reject DP complements, taking PP as canonical dependents instead:

(57)

- a. [DP Sue’s destruction [PP [P *of* [DP the city]]]]
- b. *[DP Sue’s destruction [DP the city]]

Bearing in mind that prepositions are analyzed as T heads by Pesetsky & Torrego (2004; 2006; 2007), the generalization in (58) emerges:

(58) **KEY OBSERVATIONS ABOUT COMPLEMENTS OF N AND V**

- a. A complement of N must be headed by valued T
- b. A complement of V must be headed by [unvalued T]⁴⁴

[adapted from Pesetsky & Torrego 2006: 8]

Focusing on what interests us the most, (58) can be reformulated as (59):

(59) **EXTERNAL-MERGE GENERALIZATION**

- a. V seeks to Merge with syntactic objects bearing unvalued T
- b. N seeks to Merge with syntactic objects bearing valued T

⁴⁴ For reasons that will be relevant in chapter 4, I modify Pesetsky & Torrego’s (2006) original formulation, which is as in (i):

(i) A complement of V must be headed by *valued* φ .

Though appealing, (59) must face some problematic cases, one of which is external Merge of V and a CP introduced by *that*, which is itself another instance of valued T within Pesetsky & Torrego's (2001; 2004; 2006; 2007) system. Since this issue belongs to a broader discussion about the C-T connection, I will postpone discussion until the next section.

In the preceding pages I have outlined the basics of a proposal whereby every application of Merge involves feature sharing, following original ideas by Boeckx (2002a), and recently updated by Pesetsky & Torrego (2006).

3.3. T-to-C Movement

One of the most appealing aspects of Pesetsky & Torrego's (2001) system is that it does not restrict its empirical coverage to Case: it has interesting consequences for different intriguing phenomena. Let us consider them in this section, trying to elucidate whether the basic facts extend to NSLs.

Capitalizing on robust evidence stemming from Den Besten (1983) showing that T-like elements (e.g., conjunctions, prepositions, verbs, etc.) move to C (mainly in V2 languages), Pesetsky & Torrego (2001) make the following assumption about the C-T connection:

(60) MOTIVATION FOR T-TO-C MOVEMENT (in English matrix interrogative clauses)

C bears an uninterpretable T feature (henceforth [uT]) (with the EPP property)

[from Pesetsky & Torrego 2001: 360]

(60) is interesting in that it reinforces the relation between C and T_S , which is what Chomsky himself is lately pursuing (see Chomsky 2004; 2007; to appear). Much literature has underscored the fact that C, T_S , and v^* establish a strong syntactic connection, as indicated by the facts in (64) and (65), where it is shown that complementizers can manifest both agreement and finiteness features (see Carstens 2003, Fortuny 2007, Haegeman 1998, Pesetsky & Torrego 2001; 2004, and Zwart 1993; 2001, among others):

(61) *φ-features spelled-out in C*

a. ... [CP C dat ze komt] (Dutch)

that she come-3.SG

'... that she comes'

b. ... [CP C datte ze komme] (Dutch)

that-PL they come-3.PL

'... that they come'

[form Zwart 2001: 40]

(62) *Finiteness features spelled-out in C*

a. John thinks [CP C that [TP Mary T_S is fine]]

b. John wants [CP C for [TP Mary T_S to be fine]]

In this section I would like to focus on the dependencies that C, T_S, and *v** establish during the CP phase, turning to those holding among *v**, T_O, and V in chapters 3 and 4.

Interestingly (and rather puzzlingly, from a purely historical perspective), T_S is the element whose leading role has been minimized along Chomsky's recent writings, for it is essentially regarded as a dummy element, a mere place holder of properties that belong to C.⁴⁵ Chomsky (2007; to appear) defends this thesis in the case of *φ*-features, evoking the role of the PIC (see section 2.2.). It is in this context that Pesetsky & Torrego's (2001) hypothesis that C bears uninterpretable T becomes interesting: do T features truly belong to C, much like *φ*-features? Chomsky (2007) sketches two possible answers to this question:

What is true of agreement features appears to hold as well for Tense: in clear cases, T has this feature if and only if is selected by C, though C never (to my knowledge) manifests Tense in the manner of *φ*-features in some languages. If that is basically accurate, then *there are two possibilities. One is that Tense is a property of C, and is inherited by T. The other is that Tense is a property of T, but receives only some residual*

⁴⁵ If this were so, one wonders why T_S exists at all. Chomsky's (2007; to appear) answer is that T must exist for C to be able to get rid of its uninterpretable morphology. Moreover, one also wonders why T_S must be projected in structures where C is not: raising and ECM constructions. In that respect, Chomsky (2007: 21) suggests that "[t]he UG principle that inserts T before *v**P is generalized, thus preventing automatic crash at a later stage if C is [not] merged by [external Merge]."

interpretation unless selected by C (or in other configurations, e.g., in English-like modal constructions). [from Chomsky 2007: 20 –emphasis added, AJG]

Chomsky (2007: 20) reports empirical and conceptual motivation in favor of the second option, noting that inheritance is not forced, since Tense is interpretable. Chomsky’s (2007) conclusion, therefore, is not incompatible with Pesetsky & Torrego’s (2001) as far as I can see: the T feature can be taken to appear in both T_S and C, though in a different fashion –valued in T_S, unvalued in C. Putting all the pieces together, I tentatively propose that clause structure emerges as in (63), assuming tense and agreement features to be shared by C, T_S, T_O, v*, and V:

(63) **CLAUSE STRUCTURE (feature sharing)**

[_{CP} C_{[φ][T]} [_{TP} T_S_{[φ][T_{NOM}]} [_{v*P} v*_{[φ][T]} [_{TP} T_O_{[φ][T_{ACC}]} [_{VP} V_{[φ][T]} . . .]]]]]

Let us now go back to (60), dissecting the elements involved. Given our discussion in section 2.2. we must clarify what Pesetsky & Torrego’s (2001) “EPP property” is intended to mean. In Pesetsky & Torrego’s (2001) system, the EPP is regarded as a trait of a feature, not a feature itself. Thus, if a given feature (say, the φ-bundle) bears Pesetsky & Torrego’s (2001) EPP property, it will trigger internal Merge (making it ‘strong,’ a notion supposed to capture the overt/covert nature of operations in previous formulations; see Chomsky 1993a; 1995b). I will continue to assume that the EPP property is a mere Merge requirement creating complements or specifiers (in section 2.2. I referred to this as “EPP₁”).

In order to see how Pesetsky & Torrego’s (2001) (60) works, consider the paradigm in (64), first noticed by Koopman (1983), and reinterpreted by Pesetsky & Torrego (2001) in T-to-C terms:

(64) *T-to-C Asymmetry in Matrix Interrogative Clauses*

- a. [_{CP} What_i C did_j [_{TP} Mary T_{Sj} buy t_i]]?
- b. * [_{CP} What_i C [_{TP} Mary T_S bought t_i]]?
- c. * [_{CP} Who_i C did_j [_{TP} t_i T_{Sj} buy the book]]? [unless *did* is focused]
- d. [_{CP} Who_i C [_{TP} t_i T_S bought the book]]?

[from Pesetsky & Torrego 2001: 357]

Descriptively speaking, it is clear what is going on in (64): *do*-insertion is blocked whenever the subject DP undergoes *wh*-movement to SPEC-C. According to Pesetsky & Torrego's (2001), *do*-insertion is barred *whenever a subject wh-phrase moves* because the nominative Case feature of the subject DP can value C's T, rendering *do*-insertion redundant. Graphically:

(65)

- a. [_{CP} Who_i[_{TNOM}] C[_{TNOM}] [_{TP} t_i T_S[_{TNOM}] bought the book]]
 b. * [_{CP} Who_i[_{TNOM}] C[_{TNOM}] did_j[_{TNOM}] [_{TP} t_i T_{Sj}[_{TNOM}] buy the book]]

Under the asymmetry in (65) lies a core property of the computational system: economy. As the reader may easily see, if one computational step (here, *wh*-movement) suffices to value two features, no extra operations are needed. In (65), the T feature of the subject DP is closer to C than T_S itself (taking c-command, and not node-counting, to signal closeness), so it can be used to check its T and *wh* features. Hence, by some general principle of computational efficiency driving syntax -like (66)-, the movement of the subject DP seems to be enough to satisfy C's requirements. On the other hand, the logic just sketched predicts that, when object DPs move, T_S is always closer to C, so pure T-to-C movement (i.e., *do*-insertion) must occur.

(66) **ECONOMY PRINCIPLE**

A head H triggers the minimum number of operations necessary to satisfy the properties (including EPP) of its uninterpretable features

[from Pesetsky & Torrego 2001: 359]

The analysis of *do*-insertion in (65) might be threatened by Chomsky's (1986a) *vacuous movement analysis* of subjects, whereby *wh*-subjects remain in SPEC-T_S without ever moving to SPEC-C. Pesetsky & Torrego (2001: 36) argue otherwise by considering the distribution of expressions like *the hell*, which are only allowed in *wh*-phrases that overtly move to SPEC-C (see Pesetsky 1987):

(67)

- a. [_{CP} What *the hell*_i C did [_{TP} Sue T give t_i to whom]]?
 b. * [_{CP} What_i C did [_{TP} Sue T give t_i to whom *the hell*]]?

- c. [_{CP} Who *the hell*_i C [_{TP} t_i T bough what]]?

It is not clear, though, that this *the hell* test tells us whether there is actual raising. As independently noted by Andrew Nevins and Luis Vicente (p.c.), *the hell* XPs obey a phonological constraint that affects final positions. We can see this in (68), where a wh-phrase in a sluicing context also rejects the *the hell* chunk. The problem is –as Nevins and Vicente point out– that wh-phrases in sluicing are generally taken to occupy SPEC-C (see Lasnik 1999b; 2001b):

- (68) John hired someone, but I do not know [_{CP} who (**the hell*) C [_{TP} ~~he hired t~~]]

Accordingly, the problem with *the hell*, it would appear, is not related to movement, but to final positions.

A piece of evidence that does prove *the hell* XPs to be ruled out unless movement takes place comes from the pair in (69), where no phonological constraint seems to be applicable:⁴⁶

- (69)

- a. [_{CP} Who_j C [_{TP} t_j wondered [_{CP} who *the hell*_i C [_{TP} t_i T bought this book]]]]?
 b. * [_{CP} Who_j C [_{TP} t_j believed [_{VP} who *the hell*_i V [_{TP} t_i T_{def} [t_i bought this book]]]]]?

Pesetsky & Torrego (2001) extend their proposal to the syntax of embedded wh-interrogatives, matrix exclamative clauses, and *that*-trace effects (see Rizzi 1990; 1997, and references therein). Consider embedded interrogatives first. Pesetsky & Torrego (2001: 378) analyze them like matrix ones, with the exception that embedded C's T does not trigger T-to-C movement (mere Agree is enough):

- (70) *T-to-C dependency in embedded wh-questions*

- a. Bill asked [_{CP} what_i C [_{TNOM}] [_{TP} Mary [_{TNOM}] T_S [_{TNOM}] bought t_i]]
 b. *Bill asked [_{CP} what_i C [_{TNOM}] did_j [_{TNOM}] [_{TP} Mary [_{TNOM}] T_{Sj} [_{TNOM}] buy t_i]]

⁴⁶ See Campos (1997), Lasnik & Saito (1992), and Rizzi & Shlonsky (2007) for additional arguments against Chomsky's (1986a) *vacuous movement analysis*. Other possibilities have been suggested in the literature (see Boeckx 2002b and Fortuny 2007).

c. *Bull asked [_{CP} what_i C_[TNOM] that_j[_{TNOM}] [_{TP} Mary_[TNOM] T_{Sj}[_{TNOM}] bought t_i]]

On the contrary, both NSLs and Belfast English require T-to-C movement also in embedded interrogative clauses:

(71) En Joan va preguntar . . .

the Joan AUX-3.SG ask-INF

'Joan asked . . .

a. *[_{CP} qué_i C_[TNOM] [_{TP} la Maria T_S va dir t_i]] (Catalan)

what the Maria AUX-3.SG say-INF

b. [_{CP} qué_i C_[TNOM] va dir_j[_{TNOM}] [_{TP} la Maria T_{Sj}[_{TNOM}] t_j t_i]] (Catalan)

what AUX-3.SG say-INF the Maria

c. *[_{CP} qué_i C_[TNOM] que_j[_{TNOM}] [_{TP} la Maria T_{Sj}[_{TNOM}] va dir_j t_i]] (Catalan)

what that the Maria AUX-3.SG say-INF

' . . . what Maria said'

(72)

a. She asked [_{CP} who_i C_[TNOM] had_j[_{TNOM}] [_{TP} I T_{Sj}[_{TNOM}] seen t_i]] (Belfast English)

b. I wonder [_{CP} which dish_i C_[TNOM] that_j[_{TNOM}] [_{TP} they T_{Sj}[_{TNOM}] picked t_i]] (Belfast English)

[from Pesetsky & Torrego 2001: 378]

As for matrix exclamative clauses, Pesetsky & Torrego (2001) propose that their C's T is valued by internal Merge of the subject DP, and not by T-to-C movement. That would account for why *do*-support is barred in these structures: since the subject can already do that job, T-to-C movement would be redundant.

(73) *T-to-C dependency in matrix exclamative clauses*

a. *[_{CP} What a silly book_i C_[TNOM] did_j[_{TNOM}] [_{TP} Mary T_{Sj}[_{TNOM}] buy t_i]]!

b. [_{CP} What a silly book_i [_{CP} Mary_j[_{TNOM}] C_[TNOM] [_{TP} t_j T_S[_{TNOM}] bought t_i]]]!

[from Pesetsky & Torrego 2001: 376]

Importantly, the different strategy to value C's T is not innocuous to interpretive effects. In order to capture this, Pesetsky & Torrego (2001) propose the interpretive rule in (74), consistent with the claims made in section 2.2.

(74) **EXCLAMATIVE VS. INTERROGATIVE INTERPRETATION (in matrix clauses)**

A matrix CP whose head bears *uWh* is interpreted as an exclamative if a non-wh-phrase appears as one of its specifiers. Otherwise, it is interpreted as a question.

[from Pesetsky & Torrego 2001: 377]

Consider, finally, the case of *that*, which (like *do*) is not treated as a complementizer by Pesetsky & Torrego (2001), but a clitic launched from T_S. If that is correct, then we can offer an account as for why (local) subject extraction and *that* exclude each other in English (the constraint known as “*that*-trace effect”): since they can both potentially value C’s T, on economy grounds, only one should do the job.

(75) *that*-trace effect

- a. [CP Who_i[T_{NOM}] C_[T_{NOM}] did [TP John say [CP t_i C_[T_{NOM}] [TP t_i T_S[T_{NOM}] called Mary]]]]?
 b. *[CP Who_i[T_{NOM}] C_[T_{NOM}] did [TP John say [CP t_i C_[T_{NOM}] that_j[T_{NOM}] [TP t_i T_S[T_{NOM}] called Mary]]]]?

If *that* values C’s T, and if deletion of uninterpretable features is required for convergence, one might next wonder what to do with *that*-deletion in embedded contexts. How is C’s T deleted in those cases? Pesetsky & Torrego (2001) argue that when C is merged with the so far assembled structure, both T_SP and SPEC-T_S can delete C’s T, since, c-command-wise, both are equally close to C (they are equidistant, in Chomsky’s 1993a; 1995b sense).^{47 48} This is how Pesetsky & Torrego (2001) account for so-called “complementizer deletion.”

(76) *Complementizer deletion*

- a. John thinks [CP C_[T_{NOM}] that_j[T_{NOM}] [TP Mary_i T_S[T_{NOM}] [TP t_i v* called Sue]]]
 b. John thinks [CP Mary_i[T_{NOM}] C_[T_{NOM}] [TP t_i T_S[T_{NOM}] [TP t_i v* called Sue]]]

⁴⁷ Another possibility would be for C to value its T feature by mere Agree. I assume that this is what happens in matrix declarative clauses, for instance.

⁴⁸ As Omer Preminger (p.c.) indicates to me, there are some exceptions to this general pattern: factive verbs (e.g., *to regret*, *to realize*, etc.) and some verbs involving a manner component, like *to whisper*, do not allow *that*-deletion. This may be related, as Juan Uriagereka informs me, to the ungoverned status of factive complements, which are generally taken to include extra structure (the covert noun *fact*). See Etxepare (1997) and Ormazabal (2005) for recent discussion about factive dependents.

Although I say T_SP, note that it is actually the T_S head (spelled-out as *that*) that moves to C in (76b). Pesetsky & Torrego (2001) discuss this matter in some detail, arguing that it is the head of the complement, rather than the complement itself, that moves in order to prevent a derivation in which C merges with the same syntactic object (namely, T_SP) twice. As I understand it, Pesetsky & Torrego (2001) basically want to block the anti-locality configuration in (70) (see Abels 2003), where CP merges with T_SP as both its complement and its specifier:

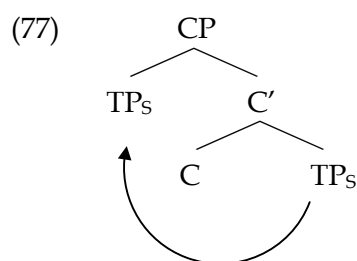

Pesetsky & Torrego (2001) formalize this anti-locality effect as the *Head Movement Generalization* –as they note, the flipside of Travis’ (1984) *Head Movement Constraint*.

(78) **HEAD MOVEMENT GENERALIZATION (HMG)**

- Suppose a head H attracts a feature of XP as a part of movement operation
- a. If XP is the complement of H, copy the head of XP into the local domain of H
 - b. Otherwise, copy XP into the local domain of H

[from Pesetsky & Torrego 2001: 363]

Needless to say, there are various aspects worth discussing about Pesetsky & Torrego’s (2001) HMG, the nature of head movement (Internal head Merge), and the notion of equidistance. Given that I assess the HGM and head movement in the next section, I will defer discussion temporarily (as for equidistance, I have to postpone this topic until next chapter as well).

In this section I have presented the main points of Pesetsky & Torrego’s (2001) analysis of the C-T_S interaction, which follows from C bearing a T feature that can be valued in different ways: by Agree (C, T_S), by head movement of T_S (*that* and *do* being treated as clitics launched from T_S), and by internal Merge of subject DPs. Before going ahead, one aspect of Pesetsky & Torrego’s (2001) T-to-C framework must be qualified.

Because of the nature of A-chains within *Phase Theory*, it seems problematic for subject DPs to be visible for checking purposes in the CP layer once they have become the specifier of T_S –recall that under Chomsky’s (2007: 25; to appear: 17) system, a DP in SPEC-T_S is “invisible to EF,” a direct consequence of Chomsky’s (2000; 2001) *Activity Condition* (see chapter 1). The difference I am highlighting is the one depicted in (79):

(79)

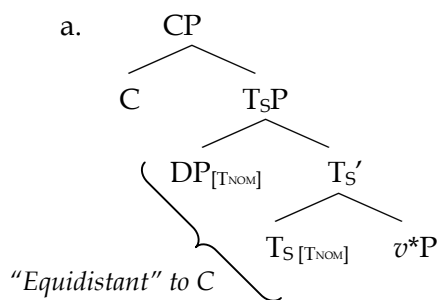

Pesetsky & Torrego (2001; 2004)

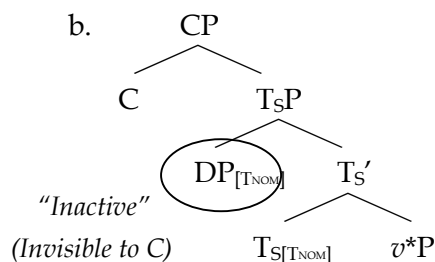

Chomsky (2000; 2001)

Granted, C’s T feature is not like Chomsky’s (2007; to appear) EF or Rizzi’s (1997; 2004; 2006) [wh], so one could still argue that Chomsky’s (2000; 2001) *Activity Condition* is irrelevant here, but it is certainly odd for A-chains to end in SPEC-C –they are typically taken to terminate in SPEC-T_S.

A possible way out, compatible with both Chomsky’s (2000; 2001) and Pesetsky & Torrego’s (2001) systems is to explore the possibility for C to value its T feature by (long-distance) Agree with the subject in SPEC-v* –that is consistent with subject DPs being able to value C’s T (as Pesetsky & Torrego 2001 hold), but never by means of internal Merge. If this idea is on track, then one has to accept equidistance as well, but this time between T_S and the *in situ* subject DP, as indicated in (80):

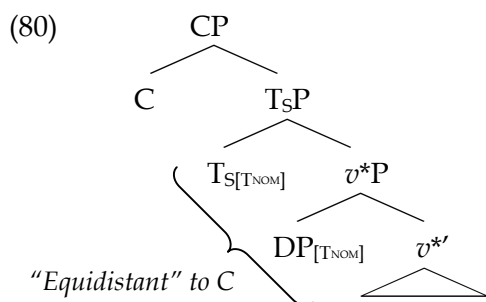

From this perspective, complementizer deletion would be as shown in (81), where the subject DP *Mary* never ends up in SPEC-C: once moved to SPEC-T_S, no computational operation can target *Mary*, since this has become ‘inactive’ (or ‘unaccessible,’ as per Boeckx 2006b):⁴⁹

(81) *Complementizer deletion*

- a. John thinks [CP C_[T] [φ] [TP T_S[T_{NOM}] [φ] [_v*P *Mary*_[3.SG] [T] *v** called Sue]]]
 b. John thinks [CP C_[T_{NOM}] [3.SG] [TP *Mary*_i[3.SG] [T_{NOM}] T_S[T_{NOM}] [3.SG] [_v*P t_i *v** called Sue]]]

An additional empirical argument in support of subject DPs never moving from SPEC-T_S to SPEC-C for checking can be drawn from Fujii & Ono’s (2006) analysis of English exclamatives. As these authors note, matrix and embedded exclamatives allow sluicing (an instance of TP ellipsis; see Ono 2006 for recent discussion):

(82) John wrote an extremely long paper, . . .

. . . and it’s unbelievable [CP what a long paper_i C [TP ~~John T wrote t_i~~]]

[from Fujii & Ono 2006: 11]

(83)

Speaker A: Colin just got \$50,000 computer for a Research Assistant.

Speaker B: [CP What an expensive computer_i C [TP ~~Colin T got t_i for a Research Assis.~~]]

[from Fujii & Ono 2006: 11]

As we saw above, Pesetsky & Torrego (2001) assume that subject DPs become an inner SPEC-C in matrix exclamatives in order to check C’s T. If that were correct, the prediction –as Fujii & Ono (2006) indicate– is that subject DPs should be remnants in exclamative sluicing. (84) shows that this is not borne out:

(84) *[CP What an expensive computer_i [CP Colin_j C [TP ~~t_j T got t_j for a Research Assis.~~]]]

The example in (84) reinforces the ‘invisible’ status of DPs in SPEC-T_S –or, alternatively, the fact that no dependency can be created between SPEC-T_S and SPEC-

⁴⁹ This is consistent with the hypothesis that subject extraction takes place from a post-verbal position. See Campos (1997), Rizzi (1982; 1990; 2006), and Rizzi & Shlonsky (2007).

C, in accordance with Chomsky's (2000; 2001) *Activity Condition*. This clearly argues against Pesetsky & Torrego's (2001) idea that subject DPs can raise from SPEC-T_S to SPEC-C, but in favor of SPEC-T_S terminating A-chains.

4. Verb Movement and Phase Sliding

In this section I focus on NSLs in order to investigate whether Chomsky's (2000; 2001; 2007; to appear) and Pesetsky & Torrego's (2001; 2004; 2007) systems can be extended to their syntactic intricacies.

In previous work (see Gallego 2005; 2006a), I extended Pesetsky & Torrego's (2001) system to Spanish and Catalan, arguing that Romance interrogatives involve T-to-C movement (*contra* Barbosa 1997; 2001, Bonet 1989, Cardinaletti 2002, 2006, Guasti 1996, Ordóñez 1997; 1998a, Solà 1992, Suñer 1994, and Uriagereka 1999b, among others). Since this issue deals with the also controversial phenomenon of head movement, we should consider it in some detail.

Consider, one more time, the clausal spine so far entertained, leaving aside the low area of the v^* P phase, irrelevant for present considerations:

(85) CLAUSE STRUCTURE (feature sharing)

$$[CP C_{[T] [\varphi]} [TP T_{S[T_{NOM}] [\varphi]} [v^*P EA_{[T] [3.SG]} v^*_{[T] [\varphi]} \dots]]]$$

Before delving into T-to-C movement, we should ask why both V-to- v^* and v^* -to-T occur in the first place. The former might be universal because of categorization purposes (or word formation; see Baker 1988, Hale & Keyser 2002, Marantz 2000, and Rizzi 2006), but the latter is clearly not, which calls for parameter setting.

The first minimalist formulation of v^* -to-T movement (see Chomsky 1993a) took it to follow from feature strength, a long abandoned technical notion. According to that thesis, v^* -to-T movement did not involve the “verb raising” vs. “affix lowering” dichotomy of previous formulations (see Chomsky 1991), but followed from head movement taking place before or after Transfer:

(86) **STRONG VS. WEAK T**

- a. In Romance, ϕ -features of T are strong (v^* moves before Transfer)
- b. In English, ϕ -features of T are weak (v^* moves after Transfer)

Lasnik (1999a; 2003a) examines the different analyses of verb movement within the generative literature at length, arguing for a hybrid account whereby there are two types of V:

(87) **INFLECTED VS. BARE V**

- a. French verbs are fully inflected in the lexicon (possibly correlating with the fact that there are no bare forms; even the infinitive has an ending).
- b. *Have* and *be* are fully inflected in the lexicon (possibly correlating with the fact that they are highly suppletive).
- c. All other English verbs are bare in the lexicon.

[from Lasnik 1999a: 105; Lasnik 2003a: 12-13]

Likewise, Lasnik distinguishes two types of T: featural (French) and affixal (English).

(88) **AFFIXAL VS. FEATURAL T**

- a. T is freely an affix or a set of abstract features.
- b. Finite featural T is strong in both French and English.
- c. Affixal T must merge with V, a PF process (distinct from head movement) demanding adjacency.

[from Lasnik 1999a: 105; Lasnik 2003a: 13]

Given that the technical apparatus of both Chomsky (1993a) and Lasnik (1999a; 2003a) differs in important respects from current minimalist view on agreement, I will not lay out the specifics of such proposals. I will, however, try to recast Lasnik's (1999a; 2003a) hypothesis and couple it with Solà's (1996) theory of verbal head movement, whose basics are as indicated in (89):

(89) *In order to insert a multicategorical word in a syntactic structure. . .*

- a. Insert a copy of this word in each of the positions it contains features of.
- b. In each copy, read only the relevant features, and ignore the other features.
- c. Pronounce only the highest copy.

[from Solà 1996: 223]

Some aspects of (89) deserve comment. First, we must clarify what multicategorical words are. According to Solà (1996), these are words that contain morphemes of different categories. Hence, a verb like Spanish *cantaremos* (Eng. *we will sing*) is multicategorical, since it has verbal (i.e., *cant(a)-*), temporal (i.e., *-re*), and nominal (i.e., *-mos*) morphemes.

Consider a specific illustration of the algorithm in (89), taken from Solà (1996):⁵⁰

(90)

- a. [_{CP} C *If* [_{TP} John T_S *will* ever [_{vP} *v be* happy]]] (English)
- b. [_{CP} C *Se* [_{TP} Gianni T_S *sarà* mai [_{vP} *v ~~sarà~~* contento]]] (Italian)
- c. [_{CP} C *an mbeidh* [_{TP} Seán T_S ~~*an mbeidh*~~ ariamh [_{vP} *v ~~an mbeidh~~* sásta]]] (Irish)

[from Solà 1996: 224]

The key difference among the examples in (90) has to do with whether the relevant morphemes are free or bound: in Italian and Irish, tense morphemes are bound, while they are free in English. Assuming these languages have the same clause structure, the facts in (90) show a mismatch between syntax (which requires three distinct positions for three morphemes *if*, *will*, and *be*), and inflectional morphology, which glues (some of) these morphemes together in a single word –a multicategorical word. From Solà’s (1996) point of view, then, head movement is connected to whether a word is multicategorical or not.

With this brief sketch in mind, let us go back to *v**-to-T movement. Solà (1996) considers three possible scenarios:

⁵⁰ In order to correctly reproduce Solà’s (1996) proposal, I use deleted copies and not traces.

(91)

- a. V is inflected for tense, and there is overt movement (a copy of the verb is inserted in both T and V).
- b. V is not inflected for tense because the tense morpheme is a free particle; there will be no movement of the verb to T; the free particle itself will be inserted under T.
- c. There is no tense morpheme in the language, and there will be no movement either (possibly a null tense morpheme will be inserted in T).

[from Solà 1996: 229]

All other things being equal, (91a) and (91b) correspond to NSLs and English respectively. I will assume so, taking it that English finite verbs do not contain tense morphology (in other words, they are *bare forms*, as Lasnik 1999a; 2003a argues): that would explain why they remain *in situ*.⁵¹

Let us now consider v^* -to-T movement in the context of *Phase Theory*. The first thing to notice is that there is no information T_S and v^* could possibly share in Chomsky's system, so trying to motivate an Agree dependency between them is difficult. Departing from traditional assumptions, Chomsky (2000; 2001; 2004; to appear) argues that ϕ -features of T_S and v^* are valued by different DPs, and thus cannot Match.⁵² The problem we face, then, is to find a feature that v^* and T_S could plausibly share, and the first candidate that comes to mind is Pesetsky & Torrego's (2001) T.

⁵¹ The same is true in the case of past forms like *kissed* in *John kissed Mary*. If Solà (1996) is right (I will assume he is without argument), *kissed* is not a past form, but actually a past participle, inflected just for aspect. See Solà (1996: 230 and ff. for discussion).

The same logic applies in the case of present forms, which are analyzed by Solà (1996) as present participles. What about (i)?

(i) John loves Mary.

That is to say, what about the *-s* morpheme attached to *love*? Following Solà (1996), I assume that (i) instantiates only number, not person, agreement; since number (and gender) agreement in participles is independent of regular subject-verb agreement, (i) poses no problem.

⁵² One caveat is in order. If Match only cares about features (see chapter 1), not their values, Case/agreement morphology of T and v^* can be matched indeed, for they both bear the relevant attribute –namely, ϕ and T. Obviously, that would make the wrong prediction that both arguments should share the same agreement or Case specification.

However appealing, it is easy to see that Pesetsky & Torrego’s (2001) system, as defined so far, presents exactly the same problem Chomsky’s (2000; 2001) does: I have assumed that the T feature of v^* is related to T_O , so it must be different from T_S ’s.

(92) *T-feature (nominative-accusative) mismatch*

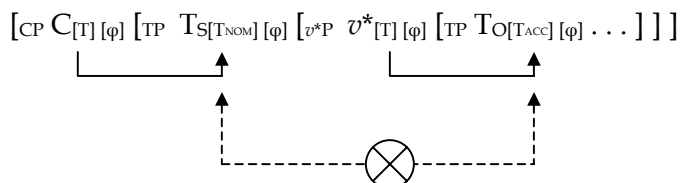

So, we are stuck, no matter the system we choose: taking either T or ϕ -features will not do, simply because the members of the relevant dependency (C, T_S , v^* and T_O) may happen to bear different (that is, incompatible) feature values.⁵³

The solution I want to propose to overcome this scenario is as follows: C, T_S and v^* can actually share one and the same feature, one that will not be Pesetsky & Torrego’s (2001; 2004; 2007) T, but real *Tense*. Though stipulative at first glance, the proposal is coherent, and will help avoid extra complications of Pesetsky & Torrego’s (2001) system. First of all, note that the putative *Tense* feature behaves as expected: it has three values.

(93) **TENSE MORPHOLOGY**

Feature	Value
<i>Tense</i>	[present]
	[past]
	[future]

Consequently, Pesetsky & Torrego’s (2001) T/Case and the Tense feature in (93) are not the same thing: T must be regarded as a species of aspect (see Svenonius 2001; 2002a; 2002b) gluing arguments to the clausal skeleton, while Tense is a deictic formative that affects the clause as a whole.

⁵³ Note, incidentally, that things are different in Pesetsky & Torrego (2007), for it is assumed that v^* ’s T feature Agrees with T_S ’s.

This hypothesis not only helps us find a rationale for v^* -to-T movement, but also helps us avoid an assumption Pesetsky & Torrego (2007) are forced to make once they realize that a CP containing a [future] specification may end up being the subject of a clause containing a [past] one, as in (94):

(94) [CP [TP [CP That the world will_{FUT} end tomorrow] T_{SPAST} frightened everyone]]

Recall that, for Pesetsky & Torrego (2001), *that* is a T_S clitic, so in (94) *that* bears all the information T_S does, its Tense specification too ([future], in the case at hand). Let us then refine (94) as in (95), supposing, with Pesetsky & Torrego (2007), that the T-values are not NOM, ACC, and the like (as I have argued), but Tense ones: [past], [present], and [future].

(95) [CP [TP [CP That_{T_{FUT}} the world will T_{T_{FUT}} end tomorrow] T_{T_{PAST}} frightened everyone]]

As Pesetsky & Torrego (2007: 24) note, the outcome in (95) is unexpected, and should in addition cause a clash between the subject CP's T and the matrix clause's, but it does not, so they suggest that the Tense values in (95) should be regarded as encyclopaedic, being computationally irrelevant (part of DM's List C).

An alternative way to tackle the odd outcome in (95) is available if T heads (T_S and T_O) bear three independent features: ϕ -features, T-features (Case proper), and Tense (a deictic anchor). I will assume so, entertaining the hypothesis that the syntactic C-T- v^* dependency is established through Tense, with verb movement being related to the Tense specification of the clause (and also with clause typing, in the sense of Cheng 1991). My point of view is therefore compatible with Koster's (2003), who compares verb movement to T_S with partial wh-movement in Germanic languages, claiming that it involves both temporal scope marking and clause typing.

Let us go back to the main question of this section: why and how does v^* -to-T movement in NSLs take place? It is a rather customary assumption that movement be triggered from above, by an 'upstairs Probe.' If so, it is unlikely that T_S can be the trigger of v^* -to-T movement: Tense information is, under any reasonable guess, already valued in T_S. I therefore propose that v^* -to-T movement is triggered by C. Or, in other

words, that v^* -to-T movement is really partial v^* -to-C movement. The scenario would be as depicted in (96), where I represent the Tense attribute as “TNS:”

(96)

- a. $[_{CP} C_{[TNS]} [_{TP} T_{[TNS_{PRESENT}]} [_{v^*P} v^*_{[TNS]}]]]$ *Multiple Match*
- b. $[_{CP} C_{[TNS_{PRESENT}]} [_{TP} T_{[TNS_{PRESENT}]} [_{v^*P} v^*_{[TNS_{PRESENT}]}]]]$ *Valuation*
-

The abstract dependency in (96) is an optimal candidate to represent what Hiraiwa (2005) calls *Multiple Agree* (a one-to-many Probe-Goal dependency; details in chapter 3). In (96), C acts as a multiple Probe which matches T_S and v^* simultaneously. After Match (C, T_S , v^*), C and v^* can value their Tense feature through T_S 's.

Given the logic in (96), it is C that raises v^* to T_S , a fact I would like to take advantage of by arguing that T_S is not different (say, affixal vs. featureal, *as per* Lasnik 1999a; 2003a) across languages: instead, C is. Pushing this thesis further, I endorse (97), a radical version of Borer's (1984) conjecture with respect to parametrical variation:

(97) **PARAMATER SETTING ASSUMPTION**

Parametrical variation is restricted to phase heads (C and v^*)

The proposal just sketched, coupled with Solà's (1996) and Lasnik's (1999a; 2003a) claims about verbal morphology, can account for why English lacks v^* -to-T movement: because v^* is a bare form, and contains no Tense feature, there can never be a direct dependency between C and v^* . In NSLs, on the other hand, v^* is inflected for Tense, and can engage syntactic dependencies with T_S and C.

Also relevant is the fact that, according to (96), C values its Tense feature independently of movement, something I want to relate to interpretive effects. That is to say, in the unmarked situation (i.e., matrix declarative clauses), C does not attract any LI or XP, but whenever it does, a semantic effect emerges: the clause is usually interpreted as non-matrix or gets a particular modal interpretation (e.g., interrogative,

(99)

- a. [CP **C** [TP John_i T_S [_{v*P} t_i v* called Mary]]] Matrix declarative
- b. [CP C **Did**_i [TP John_j T_S_i [_{v*P} t_j v* call Mary]]]? Matrix interrogative
- c. [CP C **That**_i [TP John_j T_S_i [_{v*P} t_j v* called Mary]]] Embedded declarative
- d. [CP C **May**_i [TP the force_j T_S_i [_{v*P} t_j v be with you]]] Matrix exhortative

So far, nothing has been said about the technical problems posed by head movement (see Vicente 2007 for recent discussion). In this regard, consider the reasons

On the contrary, modals, *estar* (Eng. *be*), and other verbal complexes can easily move to C:

- (iii) Con quién podrá Juan ir a Nueva York? (Spanish)
with whom may-FUT-3.SG Juan go-INF to New York
'With whom will John be able to go to New York?'
- (iv) A quién acaba Juan de hablar? (Spanish)
to whom finish-3.SG Juan of talk-INF
'Who has Juan just talked to?'
- (v) Ya estarán ellos disfrutando de la playa? (Spanish)
already be-FUT-3.PL they enjoying of the beach
'Would they already be enjoying the beach?'
- (vi) Fueron los libros devueltos por Briana o por Andrea? (Spanish)
be-PAST-3.PL the books return-PAST-3.PL by Briana or by Andrea
'Were the books returned by Briana or by Andrea?'

[from Torrego 1984: 105]

[from Suñer 1987: 683]

Suñer (1987) claims that the factor blocking (ii) is phonological: the *haber* + *past participle* cluster can be separated, it is only *ha* (Eng. *has*), a bound form, which cannot strand the participle. Suñer (1987) provides the data in (vii) and (viii) to show that *haber* can indeed be separated from past participles:

- (vii) Al haber Paco cerrado la puerta con violencia, ... (Spanish)
to+the have-INF Paco closed the door with violence
'Paco having closed the door violently, ...'
- (viii) Habiendo José nadado el largo del lago, ... (Spanish)
having José swum the length of+the lake
'José having swum the length of the lake, ...'

[from Suñer 1987: 684]

Recent findings by Paco Ordóñez (see Ordóñez 2005), however, may cast doubt on the hypothesis that it is T-to-C movement that makes Spanish and English differ. If I interpret Ordóñez's (2005) reasoning correctly, the key aspect may well have to do with whether Spanish can raise the subject in (ii) (presumably to SPEC-T_S) or not. This is precisely the explanation he offers in order to account for a micro-parametric cut teasing Spanish and Catalan apart: only Spanish licenses an extra subject position, that occupied by *Juan* in (ix). I return to these facts in chapter 3.

- (ix) Por fin puede Juan dormir. (Spanish)
at last can-3.SG Juan sleep-INF
'Juan can finally sleep'
- (x) *Finalment pot en Joan dormir. (Catalan)
finally can-3.SG the Joan sleep-INF
'Joan can finally sleep'

[from Ordóñez 2005: 4-8]

that made Chomsky (2001) corner this process to the PHON component. These are, simplifying somewhat, the following two:⁵⁶

(100)

- a. Lack of effect on the outcome (V is interpreted the same way in v^* , T, and C)
- b. Head movement violates the Extension Condition (cyclicality)

A third problem concerning head movement, Cedric Boeckx informs me, is pointed out by Abels (2003: 106-107) and concerns anti-locality. Head movement of Y in (101) creates no new feature checking configuration, in violation of Last Resort:

(101)

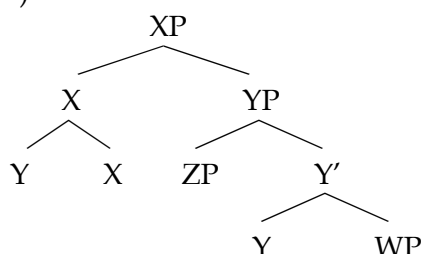

The redundancy becomes more evident once X-bar notation is dropped. As (102) shows, merger of X and Y occurs twice.

(102)

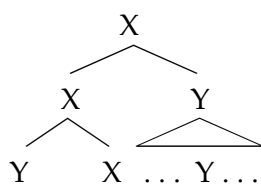

However, Chomsky (2000; to appear) does not completely preclude the possibility that head movement may operate within Narrow Syntax. Baker's (1988) *incorporation* aside, head movement appears to be genuinely syntactic in Donati's (2000; 2006a) analysis of free relatives. In these structures, as Donati (2000; 2006a) shows, the relative pronoun projects its label after moving to C. That this kind of head movement has a

⁵⁶ I cannot review additional arguments provided to reinforce the phonological nature of head movement; see Boeckx & Stjepanović (2001). See Fortuny (2007), Matushansky (2006), and Roberts (2007) for the opposite view.

semantic import in free relatives is clear from the fact that the resulting structure is interpreted as a DP, not a CP.

(103)

a. I wonder [_{CP} what town_i C you visit t_i]

Embedded interrogative

b. I shall visit [_{DP} C what_i you visit t_i]

Free relative

[from Donati 2006a: 32]

In fact, as both Donati (2006a: 25) and Vicente (2007: 50-57) observe, lack of semantic effects is due to the fact that Chomsky does not consider movement of quantificational heads (e.g., modals, negation, etc.).⁵⁷

In their analyses, Donati (2006a) and Vicente (2007) aim at unifying all kinds of movement so that the XP vs. X distinction is irrelevant.⁵⁸ Accordingly, movement is always to a SPEC position, dispensing with the GB assumption (inherited from Emonds's 1970 *Structure Preservation Hypothesis*) that there are two types of movements (phrasal movement and head movement) that target two types of positions (SPECs and heads).

Consider that possibility as depicted in (104), where Y is raised from within XP to a would-be SPEC position (not a SPEC strictly speaking, for no label projects).

(104) **HEAD MOVEMENT (Internal head Merge)**

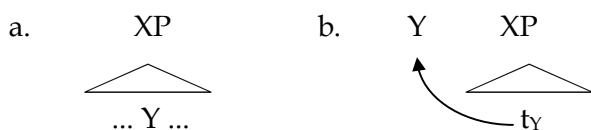

⁵⁷ See chapter 3 for a treatment of T as a quantifier. If that analysis is tenable, then T-to-C movement can be regarded as involving a quantificational head too.

⁵⁸ Donati (2006a) argues that, if movement is parasitic on Agree (thus, on features), it is odd for the system to worry about the amount of material that is actually pied-piped. Donati (2006a) does, however, assume a residual difference between XP and X movement, which does not follow from the nature of Agree, but rather from interface conditions: X-movement makes the moving element project (by Chomsky's 1995b *Uniformity Condition of Chains*), whereas XP-movement does not project. As we have seen, the distinction has semantic (interface) consequences, which has a semantic consequences.

From (104) onwards, the system has two possible choices: projecting X (the traditional move) or projecting Y.⁵⁹

(105) HEAD MOVEMENT (Internal head Merge)

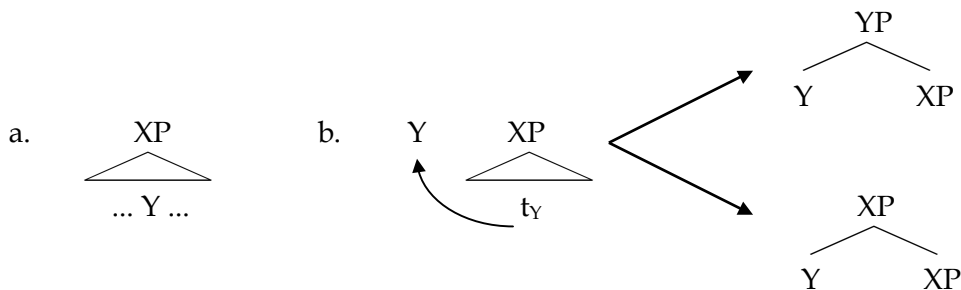

Donati (2006a) adopts the non-standard option of letting Y project, largely for uniformity worries: that is the only way for not changing the phrase-structure status of Y. In turn, Vicente (2007), which dispenses with Chomsky’s (1995b) *uniformity* entirely,⁶⁰ endorses Matushansky’s (2006) hypothesis that, after movement to a SPEC position, Y undergoes a “rebracketing mechanism that operates under structural adjacency,” fusing Y with X:

(106) MORPHOLOGICAL MERGER (see Matushansky 2006 and Vicente 2007)

a. Step 1: Y to SPEC-X movement

b. Step 2: Morphological merger of Y and X

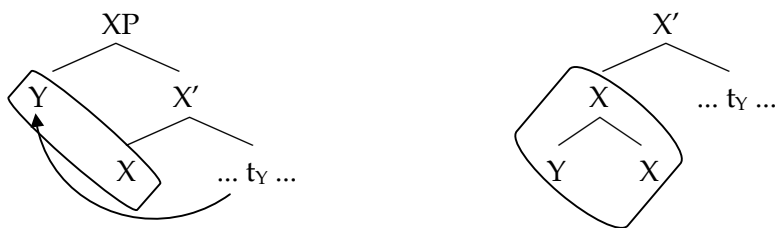

Vicente (2007) takes this process to occur within syntax (*contra* Chomsky 2001 and Matushansky 2006), but with no checking going on. That is, for Vicente (2007: 17) head

⁵⁹ See Hornstein & Uriagereka (2002) for related ideas, to which I return in chapter 3.

⁶⁰ Vicente (2007: 42) provides only one reason to dispense with uniformity, arguing that “there doesn’t seem to be anything else in the grammar that it could be relevant for. Its only purpose seems to be to restrict the shape of movement chains.” Although I think that something like uniformity depends on how dynamic syntax is (see Hornstein & Uriagereka 2002), it is possible to regard uniformity as a condition related to avoiding tampering of syntactic objects (in particular, I am thinking of Chomsky’s 1995b *inclusiveness*). From this perspective, there is a rationale for something like uniformity to be invoked.

movement is triggered “to create a larger morphological unit,” while “phrasal movement happens for feature checking reasons.” Below I depart from this possibility, arguing that (some instances of) v^* -to-T movement does involve feature checking in terms of Agree.

Chomsky (to appear: 12) essentially accepts Donati’s (2006a) reasoning, reinterpreting it in accord with the labeling algorithms in (107). Thus, head movement of X to Y creates a hybrid label, Y/X: “that is, the two labels coexist, in accord with a literal interpretation of the labeling algorithm [107].”

(107) LABELING ALGORITHMS

a. In $\{H, \alpha\}$, H an LI, H is the label

b. If α is internally merged to β , forming $\{\alpha, \beta\}$, then the label of β is the label of $\{\alpha, \beta\}$

[from Chomsky to appear: 11]

Here I want to extend Chomsky’s (to appear) interpretation of Donati’s (2006a) analysis to verb movement, arguing for a process along the lines of (108)-(109) in the case of $I_{hM}(v^*, T)$: C launches a tense Probe that simultaneously matches T_S and v^* , raising the latter to the former.

(108) Multiple Agree (C, T, v^*)

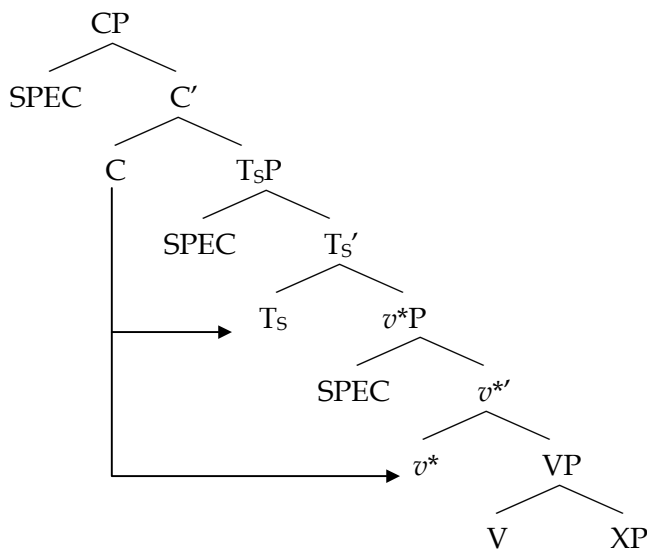

(109) IhM (C, T, v^*)

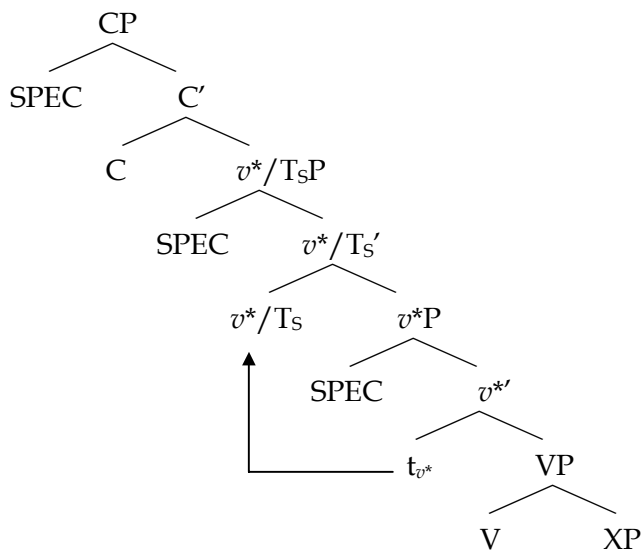

For consistency, the logic must be extended to Pesetsky & Torrego's (2001) T-to-C movement. Consider, therefore, the representation in (110):

(110) *T-to-C Movement*

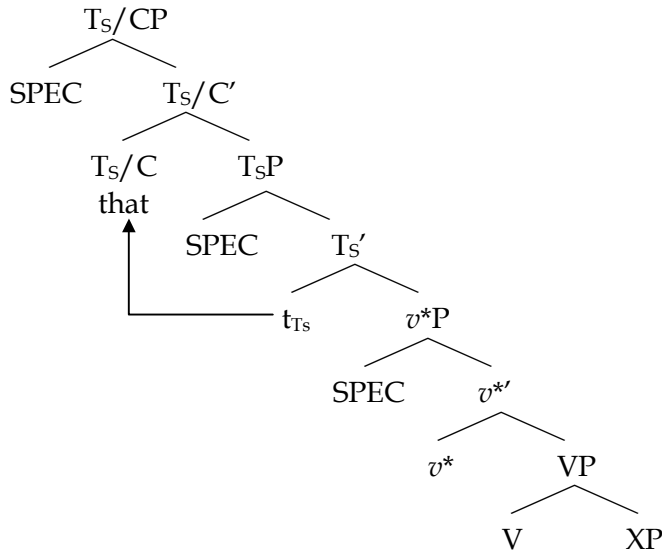

The resulting picture is now one where head movement yields hybrid labeling – which, strictly speaking, eliminates anti-locality worries: prior to v^* -to-T movement “ v^*/T ” was not there, so the operation is not vacuous in the technical sense.

I want to emphasize that the v^* -to-T process depicted in (108)-(109) directly bears on the notion of phase: in particular, as can be seen, the v^*P phase is somehow ‘moved

upwards' to T_SP, a possibility which strongly recalls two (long abandoned) strategies in the generative literature concerning head movement. The closest one goes back to Chomsky (1993a; 1995b), where verbal head movement resulted in the extension of “checking domains” (see Den Dikken 2006; 2007 for ample discussion).

More interestingly, the idea was already present in Chomsky's (1986a) *Barriers*, where it was argued that *v**-to-T movement (V-to-INFL, at the time) resulted in an amalgamated form, dubbed “V_I,” which was capable of removing VP's *barrierhood*. In Chomsky's (1986a) system, T did not L-mark *v**P (for discussion, see Chomsky 1986a: 10-20), which was the key for *v**P being first a *Blocking Category*, and, as a consequence of it, a *Barrier*.⁶¹

If the process in (108)-(109) takes place within Narrow Syntax, as I am assuming, *v**, the strong phase head, can still be said to be the center of the resulting structure and, in principle, it should be able to trigger any syntactic operation from its derived position. In plain terms, it is ‘as if’ we were pushing up the *v**P phase, with a sort of upstairs inheritance, an idea already explicitly put forward in Chomsky (1986a: 72). Like in Gallego (2005), I will refer to this process as *Phase-Sliding*:

⁶¹ Lasnik & Saito (1992) also arrived at a virtually equivalent proposal, with consequences for both subject extraction and subject sub-extraction. The main difference between Chomsky's (1986a) and Lasnik & Saito's (1992) accounts concerns the barrier-like status of VP (and also whether or not a subject can be properly governed). For Lasnik & Saito (1992) VP was never a barrier to begin with, so, building on work by different scholars (e.g., Belletti & Rizzi 1981, Huang 1982, Jaeggli 1982, Rizzi 1978; 1982, Sportiche 1981, and Torrego 1984), they proposed that INFL could L-mark the VP under some circumstances (for discussion, see Lasnik & Saito 1992: 2.1.1 and 5.5.2.). For the first proposal in which VP is not a barrier, see Raposo (1987).

(111) PHASE SLIDING

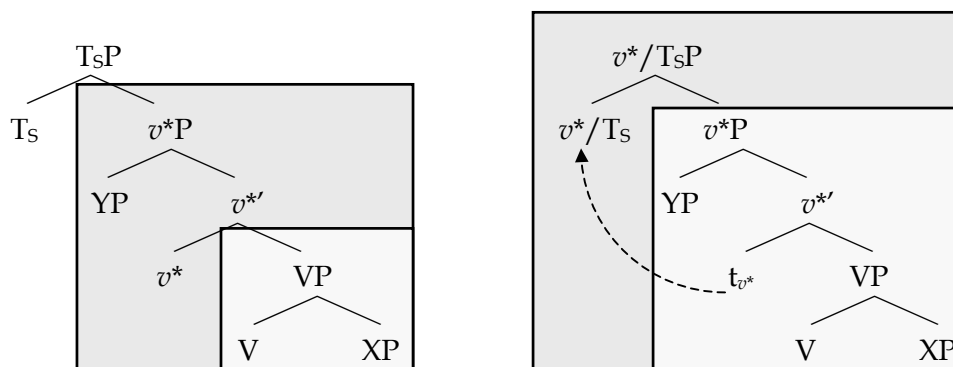

COMPLEMENT DOMAIN

EDGE DOMAIN

The claim that $T_S P$ is a phase was already suggested in Gallego (2004b). In that paper, the technical implementation assumed that T_S was present within $v^{*'}s$ Numeration (in Chomsky’s 2000; 2001 sense), but if (111) is taken literally, Gallego’s (2004b) analysis can be modified so that Chomsky’s (2000; 2001; 2004; 2007; to appear) *Phase Theory* is left intact, since it is v^* and C (and not T_S) that trigger all the operations.

A similar conclusion is independently reached in Richards (2006a) when considering the two definitions of Chomsky’s PIC:

(112) PHASE IMPENETRABILITY CONDITION (PIC₁)

In phase α with head H, the domain of H is not accessible to operations outside α ; only H and its edge are accessible to such operations

[from Chomsky 2000: 108]

(113) PHASE IMPENETRABILITY CONDITION (PIC₂)

The domain of H [the head of a strong phase] is not accessible to operations at ZP [the next strong phase]; only H and its edge are accessible to such operations

[from Chomsky 2001: 14]

As Richards (2006a) notes, the change from PIC₁ to PIC₂ ‘reberverates’ on the search space of higher heads, and, more precisely, on T_S’s search domain: under PIC₁, T_S cannot probe into *v**’s complement domain, for this has already been transferred (PIC₁ forces Transfer as soon as phases are completed). Under PIC₂, on the other hand, T_S can still probe into *v**’s domain because Transfer is delayed until the next phase head, C, is introduced in the derivation.

As pointed out by Richards (2006a), this adjustment is not rethorical terminology: empirically, PIC₂ is needed in Icelandic ‘Dative-Nominative’ constructions involving quirky subjects (see Boeckx 2000a and Sigurdsson 1996), where [number] agreement between T_S and *in situ* nominative object crosses a phase boundary. The same seems to be true in Spanish (see Masullo 1992; 1993 for original discussion of the basic data; see López 2006 and Rivero 2006 for recent refinements):

- (114) A Scorsese le gustan las tramas mafiosas. (Spanish)
 to Scorsese CL-to-him like-3.PL the plots mafia
 ‘Scorsese likes plots about the mafia’

The major consequence of the PIC₁ – PIC₂ comparison is that T_S shares search space with C under PIC₁, but with *v** under PIC₂ (the search space of C and *v** never varies). Richards (2006b) suggests to recruit this asymmetry as to indicate that whereas C and *v** never belong to the same Numeration, T_S can belong to C’s or *v**’s: if T_S belongs to C’s Numeration, we get PIC₁; if it belongs to *v**’s, we get PIC₂.

As the reader may see, Richards’ (2006a) observations have the same effect of *Phase Sliding*, and, in fact, are virtually identical to Gallego’s (2004b) claim that T_S is present in *v**’s Numeration. Unfortunately, it must be noted that the PIC₂ does not allow T_S to probe *v**’s domain any longer under Chomsky’s (2007; to appear) phase-head-driven version of *Phase Theory*, for C and T_S are introduced at the same time.

Let me close this section by going back to *Phase Sliding* first and then to the hybrid label notation I have assumed (*v**/T). With respect to the first issue, I want to point out a loophole: if *v**-to-T movement is responsible for *Phase Sliding*, then C, the other phase head, must also be active at that point, for it is C –according to what I said above– that

triggers v^* -to-T movement. In short, it appears that the two phases, CP and v^* P, must be simultaneously active. In order to get around this scenario (that is, to eliminate the cumbersome situation where CP and v^* P appear to be collapsed) I want to suggest that, although there are only two phasal domains, there are 3 applications of Transfer within a clause: one transferring v^* 's complement domain (see 115a), a second one transferring v^*/T_s 's (see 115b, after v^* -to- T_s movement), and a last one transferring C's (see 115c). Put another way: I want to argue that *there is no extra phase, but an additional Transfer* taking place between v^* P and CP, the one corresponding to *Phase Sliding*.⁶²

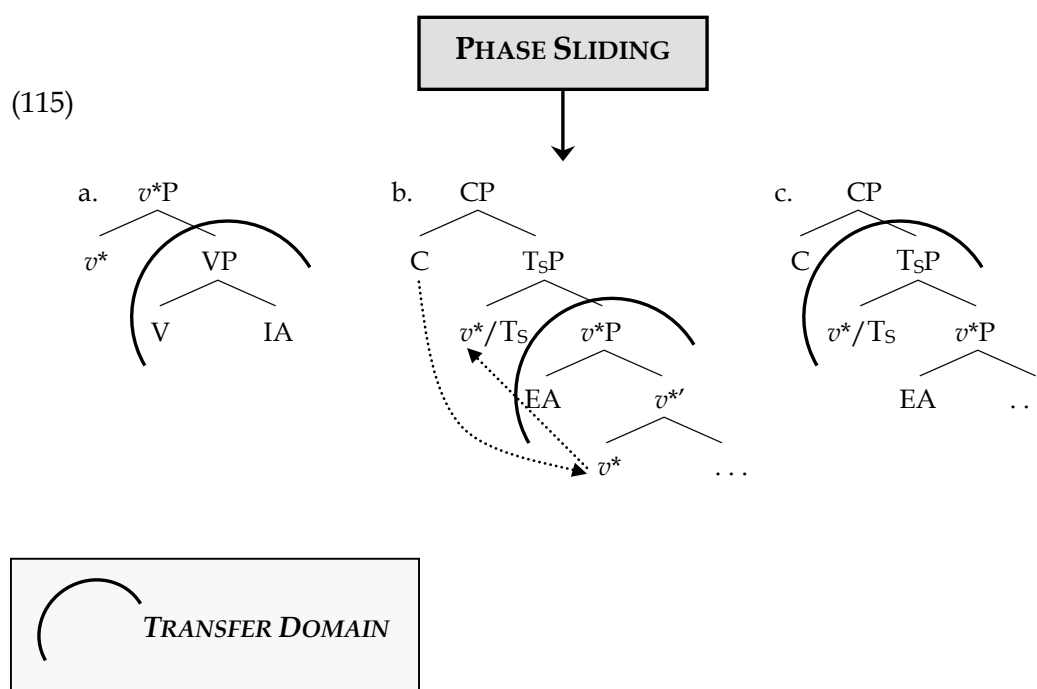

The question that this scenario poses runs as follows: why is it that v^* -to-T movement triggers an additional Transfer as soon as the CP phase starts? Why can't the derivation wait a little bit more until the customary Transfer of C's complement domain (i.e., T_s P) takes place, as predicted by Chomsky's orthodox theory?

In a sense, we arrive at a scenario similar to the one behind Uriagereka's (1999b) analysis of islands in rich agreement languages. For Uriagereka (1999b), external Merge

⁶² The original formulation of *Phase Sliding* (the one put forward in Gallego 2005) also argued that there is no extra phase. However, in Gallego (2005) I did not assume that the VP is transferred before *Phase Sliding*: I assumed that Transfer of VP is delayed until v^* -to-T movement occurs.

As the reader may see, the implementation here is much closer to Chomsky's than it was in Gallego (2005).

of a DP in SPEC- T_S forces the system to trigger a Transfer. I want to pursue the intuition that morphological demands (in the sense of Uriagereka 1999b and much previous literature) trigger this additional Transfer in order to meet morphological integrity: upon head movement with T_S , the Tense feature of the T_S head is valued,⁶³ and the so far built up structure is interpreted as a convergent domain that can be submitted to the morphological component.

I want to briefly consider, finally, the hybrid label that results from IhM (v^* , T_S), which, notation wise, departs from BPS: what does it mean for a label to be hybrid? A more conservative position would entertain Donati's (2006a) analysis, taking v^* to project after moving to T_S , as indicated in (116):

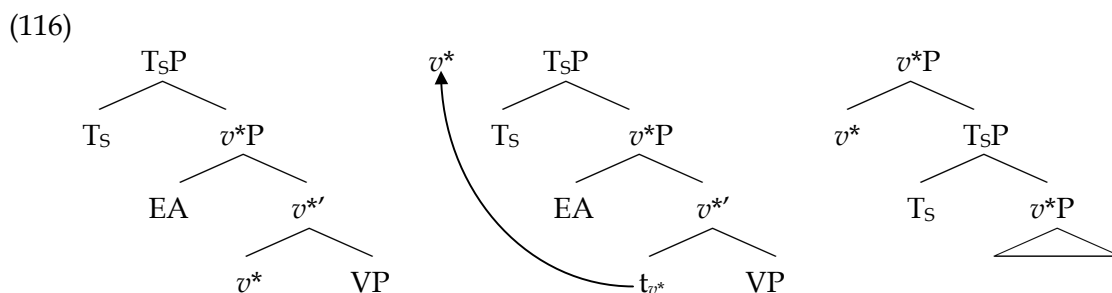

Although (116) is less worrisome than the hybrid notation, I will continue to assume the latter throughout this dissertation, following Chomsky's (to appear) argument (see Citko 2006).

In this section I have focused on v^* -to-T movement in NSLs, an operation determining parametric variation. I have pursued the idea that head movement can be regarded as syntactic if, interface-wise, it has some semantics of its own. Following Koster (2003), I have considered the possibility that head movement is related to clause typing and temporal scope dependencies: that would provide us with a different type of semantics (in accord with the SMT), explaining in turn why the process is clause-bounded.

⁶³ Although interpretable in T_S , I assume that [Tense] is valued in the verb (see Pesetsky & Torrego 2007).

Furthermore, I have put forward the idea that v^* -to-T movement is actually triggered by C, through Multiple Agree (C, T_S, v^*), with final (re)projection of v^* and T upon reaching their targets.⁶⁴

Following previous work of my own (see Gallego 2004b; 2005), I have put forward the hypothesis that v^* -to-T movement in NSLs renders the T_SP projection a hybrid phasal domain (v^*/T_{SP}), a conclusion that has strong empirical motivation (phrased in different ways) within the literature (see Barbosa 1995, Goodall 1993; 1999; 2000, Jaeggli 1982; 1985, Kayne 1989, Masullo 1992, Rizzi 1978; 1982, Solà 1992, Torrego 1984, Uriagereka 1999b, and Uribe-Etxebarria 1992; 1995). As we will see, this mechanism not only makes interesting predictions on the empirical side, but also poses non-trivial theoretical challenges, especially so for orthodox *Phase Theory* (see chapters 3 and 4).

5. Some Consequences of *Phase Sliding*

In this final section I would like to investigate some of the consequences of *Phase Sliding* for the syntax of NSLs. My goal is to show that the additional Transfer triggered by *Phase Sliding* has a crucial effect on subjects: in particular, it makes them get their Case feature checked before the CP phase proper is over, so that C cannot establish Agree with these dependents. If correct, the prediction is that, contrary to what we see in English, subjects in NSLs can never be used to value Pesetsky & Torrego's (2001) C's T feature.

Discussion is divided as follows: first, I address Torrego's (1984) *Verb Preposing Rule* (so-called *obligatory inversion*),⁶⁵ which I recruit in T-to-C terms. In so doing, I also

⁶⁴ As we will see later on (chapter 4), the predictions of this analysis fit in the case of sub-extraction from subjects. Another clear prediction of *Phase Sliding* is that, if there is C-to-V movement (i.e., a complementizer moving into a higher clause's V or some analogous exorporating process), the problems with sub-extracting from SPEC-C should vanish too. At present, I do not know how to test this prediction (see Chomsky & Lasnik 1995, who argue that there is no known C-to-V movement –but see Uriagereka 1988a).

Another question emerges: what about T-to-C movement? Can this operation extend again a phase? Cardinaletti (2001a), using different terminology, seems to suggest so. Here I will take it that T-to-C movement cannot extend a phase again: v^* -to-T movement does, but, whenever we move up to the CP domain, v^* (or v^*/T_{SP} , under my analysis) becomes 'inert' (see chapter 1), and it is C (the phase head of that domain) that triggers all the relevant operations, including T-to-C movement.

consider (and eventually dismiss) Torrego’s (1984) claim that *wh*-adjuncts do not trigger inversion in Spanish –as I show, although some of them do avoid inversion, the relevant factor is not ‘being an adjunct,’ but rather ‘pied-piping a preposition.’ Second, I turn attention to Uriagereka’s (1999b) analysis of the (weak) island effect created by preverbal subjects in NSLs, providing a T-to-C based analysis too. I end up offering a global account of both obligatory inversion and island effects that enhances the role of *Phase Sliding*.

5.1. Obligatory Inversion

Gallego (2004a; 2004b) presents an analysis of interrogative clauses in NSLs, focusing on whether obligatory inversion can be recast as involving T-to-C movement. My main objection to analyses where there is no T-to-C movement in interrogatives had to do with the fact that they adopted either Rizzi’s (1996) *Wh-Criterion* or a similar checking mechanism.

Under mainstream approaches to obligatory inversion, features must be checked in a SPEC-Head configuration. For reasons already discussed (see chapter 1 section 3.2.; chapter 2 section 2.2.), I will not assume such a technical implementation. In addition, given the system adopted so far, it would be problematic for T_s to have a [wh] feature (as Rizzi 1996 originally claimed): that would make wrong predictions. For concreteness, note that if *did* could check a [wh] feature in C, the superiority asymmetry in (117) could not be accounted for: (117a) should be ruled out, just like (117b) is, for T_s is always closer to C than the subject. Put differently: minimality wise,

⁶⁵ *Obligatory inversion* refers to verb-subject order in marked modality contexts (e.g., exclamatives, interrogatives, imperatives, etc.):

- | | | | | | |
|------|---------------------------------------|--------------|-----------|---------|-----------|
| (i) | Vino | Germán? | (Spanish) | | |
| | come-PAST-3.SG | Germán | | | |
| | ‘Did Germán come?’ | | | | |
| (ii) | Cuánta | sandez | dice | Germán! | (Spanish) |
| | how-much | stupid-thing | say-3.SG | Germán | |
| | ‘How many stupid things Germán says!’ | | | | |

The pattern in (i) and (ii) must be contrasted with *free inversion*: optional verb-subject order in unmarked modality contexts (see Belletti 2001; 2004, Uribe-Etxebarria 1992, and references therein).

- | | | | |
|-------|----------------|---------|-----------|
| (iii) | Lee | Germán. | (Spanish) |
| | read-3.SG | Germán | |
| | ‘Germán reads’ | | |

did cannot count as a ‘wh-checker,’ as it would not be consistent with the contrast in (117).

(117)

- a. [_{CP} Who_i C [_{TP} t_i T_S [_{v*P} t_i v* bought what]]]?
 b. *[_{CP} What_j C did [_{TP} who_i T_S [_{v*P} t_i v* buy t_j]]]?

The second problem for non-T-to-C movement analyses to obligatory inversion was that some of them assumed no CP projection in interrogative clauses. A sentence like (118a) would then be analyzed as in (118b), crucially adopting the so-called *VP-Internal Subject Hypothesis* (see chapter 3):

(118)

- a. Qui va veure la Maria? (Catalan)
 who AUX-3.SG see-INF the Maria
 ‘Who did Maria see?’
 b. [_{TP} Qui_i T_S va veure_j [_{v*P} la Maria v* t_j t_i]] (Catalan)

In Gallego (2004a; 2004b), I extensively reviewed Spanish data from Suñer (1994) and Ordóñez (1998a) dealing with adverbs, negation, and auxiliary verb movement, trying to argue that they do not constitute a knock-down problem for a T-to-C account of obligatory inversion.⁶⁶

In Gallego (2004b) I also presented an analysis accounting for why some wh-phrases do not obligatorily trigger inversion, trying to show that the crucial cut is

⁶⁶ The main facts regarding obligatory inversion hold for European Portuguese, Galician, Catalan, and Italian (see Barbosa 2001, Costa 2000, Gallego 2004a, Poletto & Pollock 2004, Rizzi 1996; 2001a).

There are, however, cases in which T-to-C movement does not take place, mostly depending on whether the subject is a full DP or a weak pronoun (as in French and Brazilian Portuguese; see Boeckx 2002b, Cardinaletti 2001a, and Ordóñez 2005), or whether the verb is inflected in subjunctive mood (see Rizzi 1996 and Uriagereka 1999b).

Actually, Spanish embedded interrogative clauses, which normally require inversion, can also marginally leave the verb in T to my ear, if the subject is pronominal:

(i) (?)Eso depende de cómo uno lo haga. (Spanish)
 that depend-3.SG of how one CL-it do-SUBJ-3.SG
 ‘That depends on how one do things’

independent from Torrego's (1984) original idea about the adjunct vs. argument asymmetry. To my ear, all adjuncts need inversion:⁶⁷

(119)

- a. *[_{CP} Cuándo C [_{TP} Leticia vino]]? (Spanish)
when Leticia come-PAST-3.SG
'When did Leticia come?'
- b. *[_{CP} Dónde C [_{TP} Leticia cantó]]? (Spanish)
where Leticia sing-PAST-3.SG
'Where did Leticia sing?'
- c. *[_{CP} Cómo C [_{TP} Leticia estudia]]? (Spanish)
how Leticia study-3.SG
'How does Leticia study?'

Whenever adjuncts (and arguments) do not trigger inversion, a semantic import obtains. Consider the following Spanish data:

(120)

- a. Pero, a ver: cuándo Juan ha dicho eso? (Nunca lo ha dicho...)
but, to see-INF: when Juan have-3.SG said that? (Never CL-it have-3.SG said...)
'So, tell me: When has Juan said that? He never did so...'
- b. Pero, a ver: dónde Juan es capaz de hacer esas cosas? (En ningún sitio...)
but to see-INF where Juan be-3.SG able of do-INF those things? (In no place...)
'So, Let us see: where would Juan be able of doing such things?
(Nowhere whatsoever...)

The anti-inversion pattern in sentences like (i) are becoming rather frequent in present day Spanish, with no need to invoke either subjunctive or pronominal subject.

⁶⁷ The same facts are found in Italian, according to Rizzi (2001a: 292-295):

- (i) *Dove Gianni è andato? (Italian)
where Gianni be-3.SG gone
'Where did Gianni go?'
- (ii) *Come Gianni è partito? (Italian)
how Gianni be-3.SG gone
'How did Gianni leave?'

[from Rizzi 2001a: 295]

c. No me lo creo, cómo Juan te dice esas cosas?
 not CL-me CL-it believe-1.SG how Juan CL-you say-3.SG those things?
 ‘I cannot believe it: how come Juan tells you those things?’

The judgments are a bit subtle, but the general point seems clear enough: the examples in (120) are a species of rethorical question where the speaker does not really expect an answer, but seems to be questioning the truth value of a previous assertion. In the case of (120a), for instance, the entire situation would be as in (121):⁶⁸

(121)

A: Juan dijo que el Real Madrid es el mejor equipo. (Spanish)

Juan say-PAST-3.SG that the Real Madrid be-3.SG the best team

‘Juan said Real Madrid is the best team’

B: Pero, a ver: cuándo Juan ha dicho eso? (Nunca lo ha dicho...)

but, to see-INF: when Juan have-3.SG said that? (Never CL-it have-3.SG said...)

‘So, tell me: When has Juan said that? He never did so...’

Two possibilities to analyze the data in (120) come to mind: either those wh-words move from a modality-oriented position, higher than T_S (assuming they would be endowed with T-like features), or else they move from wherever they are generated (an adjunct position, arguably), and, as a consequence of T_S not moving to C , a semantic difference arises. I will support the latter view, assuming that C 's T is valued by mere Agree in those cases.

The analysis I have in mind is therefore similar to the one Pesetsky & Torrego (2001) defend in the case of the questions vs. exclamatives: as we saw, the former delete C 's T by moving T_S (e.g., *What book **did** you buy?*), whereas the latter do so by moving the subject (e.g., *What **an impressive book** you bought!*). Since there is a different formal strategy to delete C 's T, we expect a semantic difference as well.

Uribe-Etxebarria (1992) points out another wh-element which does not trigger obligatory inversion: *cómo*. Importantly, when inversion fails, this element does not

⁶⁸ Collins (1991: 43) reaches the same conclusion when analyzing English *how come*, which he takes to “presuppose the truth of its complement.”

have the canonical manner reading (Eng. *how*), but one whose paraphrase is something like “how is it possible that...” (that is, *how come*). As expected, the interrogative sentences in which this element appears are not real questions.

- (122) [_{CP} Cómo C [_{TP} Germán te ha dicho eso]]? (Spanish)
 how Germán CL-to-you have-3.SG said that
 ‘How come Germán has said that to you?’

Ricardo Etxepare (p.c.) makes me note that (123) –but not (124)– is fine:⁶⁹

- (123) [_{CP} Qué libros C [_{TP} Juan no ha leído]]? (Spanish)
 what books Juan not have-3.SG read
 ‘What books han’t Juan read?’

- (124) * [_{CP} Qué libros C [_{TP} Juan (sí) ha leído]]? (Spanish)
 what books Juan (yes) have-3.SG read
 ‘What books has Juan read indeed?’

Again, (123) seems to me to have a similar semantics, involving a presupposition of sorts: the speaker knows that Juan has read all the books he can reasonably think of. (125) helps settle a context appropriate for that interpretation:

- (125) Pero, a ver, qué libros Juan no ha leído? ... (Spanish)
 but to see-INF what books Juan not have-3.SG read?
 ... si es que los ha leído todos!
 if be-3.SG that CL-them have-3.SG read all
 ‘But, Let us see, tell me what books Juan hasn’t read? He has in fact read them all!’

As for (124), I essentially agree with Etxepare’s judgment. However, that sentence could improve in the following context:

⁶⁹ Needless to say, this is nothing but a naïve and superficial approximation to the facts, since I cannot assess the effects that adverbs like *no* (Eng. *not*) and *sí* (Eng. *yes/emphatic do*) have, with clear implications within the realms of focus, modality, and polarity. For ample discussion on these topics see González (2008), Hernanz (2003), and Irurtzun (2006; 2007).

(126)

A: No, te equivocas: Juan no ha leído LGB ni LSLT. (Spanish)

not CL-you be-wrong-2.SG: Juan not have-3.SG read LGB nor LSLT

‘No, you are wrong: Juan has read neither LGB nor LSLT’

B: Ya, ya, pero es que yo te preguntaba otra cosa . . . (Spanish)

now now but be-3.SG that I CL-you asked-3.SG other thing . . .

. . . te preguntaba que qué libros Juan sí ha leído?

CL-you ask-1.SG that what books Juan yes have-3.SG read

‘OK, OK, but I was asking a different thing: what books has Juan actually read?’

Let us now go back to *wh*-adjuncts. Although I have mentioned that they need inversion for question formation, some adjuncts noted in Torrego (1984: 106) do seem to prevent inversion: those pied-piping a (certain type of) preposition. To my ear, the examples in (127) are fine.^{70 71}

⁷⁰ Even if a purely interrogative interpretation is possible in the examples in (127), I think the rhetoric reading is the most salient one, due to non-inversion. In addition, light prepositions (or those involved in object Case marking) do not prevent inversion in my idiolect, presumably because these do not project (that is, we are before DPs, not PPs; see chapters 3 and 4).

- (i) ??/*A quién Aritz ha llamado? (Spanish)
to whom Aritz have-3.SG called
‘Who has Aritz called?’

Unsurprisingly, some Spanish dialects, like Río de la Plata’s (Argentina), seem to prevent inversion even with *a*-marked DOs, as pointed out by Salanova (2002):

- (ii) A quién Juan conoció en Buenos Aires? (RP.Spanish)
to whom Juan know-PAST-3.SG in Buenos Aires
‘Who did Juan meet at Buenos Aires?’
- (iii) *Qué Juan vio en Buenos Aires? (RP.Spanish)
what Juan saee-PAST-3.SG in Buenos Aires
‘What did Juan see at Buenos Aires?’

[from Salanova 2002: 9]

To repeat, (iii) is out in my idiolect with no previous context. Apparently, the preposition *a* in Río de la Plata Spanish can provide its label to the whole structure.

⁷¹ Uriagereka (1988a) provides analogous examples, all of them featuring *wh*-phrases that pied-pipe a preposition:

- (i) ?A qué cine Juan ha ido? (Spanish)
to what cinema Juan have-3.SG gone
‘Which cinema has Juan gone to?’
- (ii) ?En qué momento Juan ha llegado? (Spanish)
in what moment Juan have-3.SG arrived
‘When has Juan arrived?’
- (iii) ?De qué manera Juan lo ha hecho? (Spanish)
of what manner Juan CL-it have-3.SG done
‘How has Juan done that?’
- (iv) Por qué razón Juan lo ha hecho? (Spanish)
for what reason Juan CL-it have-3.SG done
‘Why has Juan done it?’

(127)

- a. [_{CP} Por qué C [_{TP} Celia llamó a su hermana]]? (Spanish)
 for what Celia call-PAST-3.SG to her sister
 ‘Why did Celia call her sister?’
- b. (?) [_{CP} En qué medida C [_{TP} la Constitución ha contribuido a esto]]? (Spanish)
 in what measure the Constitution have-3.SG contributed to that
 ‘To what extent has the Constitution contributed to that?’
- c. (?) [_{CP} Con cuánto dinero C [_{TP} el Gobierno te ha premiado]]? (Spanish)
 with how-much money the Government CL-you have-3.SG rewarded
 ‘With how much money has the Government rewarded you?’

The case of *por qué* (Eng. *why*) has already been noted in the literature (see Uriagereka 1988a; 1988b; 1999b, and Rizzi 1996; 2001a), but it had never received a satisfactory account. Spanish speakers accept both (128a) and (128b), and they actually realize that there is a (subtle) difference in their semantics:⁷²

[from Uriagereka 1988a: 145]

Most importantly, consider the next minimal pair, taken from Uriagereka (1988b), which I think is a crucial one:

- (v) *Me pregunto [_{CP} cuándo_i Juan habrá llegado t_i] (Spanish)
 CL-to-myself ask-1.SG when Juan have-FUT-3.SG arrived
 ‘I wonder when Juan could have arrived’
- (vi) Me pregunto [_{CP} en qué momento_i Juan habrá llegado t_i] (Spanish)
 CL-to-myself ask-1.SG in what moment Juan have-FUT-3.SG arrived
 ‘I wonder at what moment Juan could have arrived’

[from Uriagereka 1988b: 519 fn.15]

Uriagereka (1988b) studies why *wh*-phrases such as *por qué* (Eng. *why*) do not trigger inversion. When it comes to the minimal pair in (v) and (vi), he observes that:

[t]he examples are virtually synonymous. It could be that when the adjunct *wh*-phrase has the phrasal structure of a prepositional phrase (and we pied-pipe the question), the option of adjunction to IP, instead of movement to Comp, is available. Crucially, *por qué* (literally, *for what (reason)*), has the structure of a prepositional phrase. [from Uriagereka 1988b: 519]

As the reader may see, despite Uriagereka (1988b) lacks a precise proposal, the very same intuition I am pursuing was already in that work.

⁷² (128) raises the question of where subjects are in *wh*-questions? If the verb has moved to C, there are two possible landing sites: SPEC-T_S and SPEC-*v**. Guasti (1996) and Ordóñez (1998a) address this issue, proposing different answers. Guasti (1996) notes that subjects always appear post-verbally in interrogative sentences, but they do not behave on a par with post-verbal subjects in declarative sentences with respect to negation scope, and analyzes them in a position out of its scope: adjoined to an AgrP. As for Ordóñez (1998b), he notes that subjects with floating quantifiers do not allow stranding, contrary to what happens in declarative sentences:

- (i) Aquellos turistas vienen todos de Francia. (Spanish)
 those tourists come-3.PL all from France

(128)

- a. [CP Por qué C [TP Celia llamó a su hermana]]? (Spanish)
 for what Celia call-PAST-3.SG to her sister
 ‘Why did Celia call her sister?’
- b. [CP Por qué C llamó [TP (Celia) a su hermana (Celia)]]? (Spanish)
 for what call-PAST-3.SG Celia to her sister Celia
 ‘Why did Celia call her sister?’

The semantics of (128b) is easy to spell-out: there is a reason *x*, such that Celia did not call her sister because of *x*.⁷³ The semantics of (128a) is more difficult to grasp, though. It seems that (128a) can mean either “Why was it Celia (and not Inés, say) who called her sister?” or else “Why was it (true) that Celia called her sister?” The second possible meaning of (128a) is related to the non-manner reading of *cómo* (Eng. *how come*).

These facts could be taken as evidence to argue that we are asking about the truth-value of the sentence, and, consequently, that we are moving some complex (modal-like) wh-phrase to C (as Jaume Solà suggests to me through personal communication). In any event, note that the semantics of these expressions is not that of a true wh-question, a fact I continue to take as evidence in favor of a T-to-C based approach.⁷⁴

-
- (ii) ‘Those tourists come all from France’
 * De dónde vienen aquellos turistas todos? (Spanish)
 of where come-3.PL those tourists all?
 ‘Where do those tourists come all from?’

[from Ordóñez 1998a: 337]

Ordóñez (1998a) takes these data to support a non T-to-C movement analysis for interrogatives, with the additional consequence that subjects cannot occupy SPEC-T_S in these structures. In the system I am assuming, there is no principled reason why subjects could not occupy SPEC-T_S. A plausible conclusion is that both positions can in principle be occupied, but informational requirements yield more or less severe deviance. Actually, (ii) is probably deviant due to informational conflicts: there are two foci (the wh-phrase and the stranded quantifier). See Belletti (2004) for additional discussion.

⁷³ As (128b) shows, the post-verbal subject can occupy two positions, presumably SPEC-*v** and SPEC-T_S (see previous fn.).

⁷⁴ Italian *perché* (Eng. *why*) and *come mai* (Eng. *how come*), like Spanish *por qué* (Eng. *why*) and *cómo diablos* (Eng. *how the hell*) do not trigger inversion either.

- (i) Perché Gianni è venuto? (Italian)
 for-what Gianni be-3.SG come
 ‘Why did Gianni come?’
- (ii) Come mai Gianni è partito? (Italian)

These observations are further reinforced by the following data, which indicate that obligatory T-to-C movement can also be blocked in embedded contexts. The key, yet again, is a preposition (*hasta*, in 129b).

(129)

- a. *No te imaginas [CP cuánto C tu padre me ha ayudado] (Spanish)
 not CL-you imagine-2.SG how-much your father CL-me have-3.SG helped
 ‘You cannot imagine how much your father helped me’
- b. No te imaginas [CP hasta qué punto C tu padre me ha ayudado] (Spanish)
 not CL-you imagine-2.SG until what point your father CL-me have-3.SG helped
 ‘You cannot imagine how much your father has helped me’

Some proposals have claimed that obligatory inversion is blocked by heavy NPs (see Ordóñez & Olarrea 2005), and not the presence of a preposition. However, as (130) shows, such an analysis cannot be on the right track: the wh-phrase in (130a) is much heavier than those of (130b) and (130c), yet only the latter can block inversion.

(130)

- a. *[CP Qué libro [que María dice que Pedro leyó]] C Juan tiene] ? (Spanish)
 what book that María say-3.SG that Pedro read-PAST-3.SG Juan have-3.SG
 ‘What book that María says that Pedro read does Juan have?’

how ever Gianni be-3.SG gone
 ‘How come Gianni left?’

[from Rizzi 2001a: 293]

Again, T-to-C movement could be blocked for the non-interrogative semantics to arise, but this is only compulsory in the case of *come mai*, not *perché*.

Rizzi (2001a) argues that these wh-elements directly merge in a position displaying interrogative force properties: SPEC-Int (for “Interrogative”). Rizzi (2001a) assumes Int can be intrinsically endowed with a [wh] feature, so merger of the relevant wh-phrase as SPEC-Int is enough to satisfy his *Wh Criterion*.

Another wh-element not displaying T-to-C movement is, obviously, English *how come*. Collins (1991) analyzes this wh-item as an LI (an idiom, to be concrete) occupying C. As this author notes, this wh-word is diachronically related to “how did it come about that” or “how comes it.” I would like to interpret this observation and relate the *come*-chunk of *how come* to the verb *come*, thus an element bearing T-morphology, in Pesetsky & Torrego’s (2001) sense. The particular analysis of *how come* does not matter much, as long as *come* is analyzed as bearing T: that suffices in explaining why it does not trigger T-to-C movement.

- b. [_{CP} Cuál de mis libros C [_{TP} Juan ha leído]]? (Spanish)
 which of my books Juan have-3.SG read
 ‘Which one of my books has Juan read?’
- c. [_{CP} A cuántos de tus estudiantes] C [_{TP} Juan ha entrevistado]]? (Spanish)
 to how-many of your students Juan have-3.SG interviewed
 ‘How many of your students has Juan interviewed?’

The examples in (130b) and (130c) are interesting in two respects: first, they show that D-linking cannot be the relevant factor preventing obligatory inversion either –for otherwise (130c) would be out; second, the prepositions of those examples, although apparently too buried within the *wh*-phrases, seem to be doing the same job T-to-C movement does: C’s T valuation. This seems to support an analysis of partitive (part-whole predications) phrases as (131), where the preposition heads the entire structure (see Uriagereka 1993; 2002a):⁷⁵

(131) [_{PP} [_P P of [_{SC} [your students] [how many]]]]

Summarizing, the preceding data show that obligatory inversion in non-declarative contexts can only be prevented if *wh*-phrases pied-pipe (certain type of) prepositions (see examples 127 through 130). When no T-to-C movement takes place and the *wh*-phrase contains no preposition, checking proceeds at a distance (through Agree), and there is an additional semantic effect: the interrogative structure is interpreted as a rethoric question.

⁷⁵ See Bruccart (1997) for additional discussion. In his analysis, the PP is taken as a complement of N, hence not projecting its label.

Another possibility, still compatible with the facts in (130), is (i), (see Hale & Keyser 1998; 2002). Either way, the key factor is that P be the head of the resulting SO (P being a ‘species of T’, as in Pesetsky & Torrego 2004).

(i) [_{PP} how many [_P P of [_{DP} your students]]]

5.2. Uriagereka's (1999b) Analysis of Subjects in NSLs

In this section I want to refine the argument concerning *obligatory inversion*, relating it to the (weak) island effects created by preverbal subjects in NSLs, which in my system follow from *Phase Sliding*.

In previous work of mine I claimed that the Spanish conjunction *que* (Eng. *that*) was another instance of T_S moved to C. In this regard, I departed from Pesetsky & Torrego (2001: 381), where Torrego's (1984) facts in (132) are taken to indicate that *que* is a pure manifestation of C.⁷⁶

⁷⁶ In this thesis I am sweeping under the rug 'exotic' uses of *que*, like those in (i), (ii), (iii), (iv), and (v) (see Bruccart 1993; 1994b, Etxepare 2002 Demonte & Fernández-Soriano 2002; 2005, Suñer 1991; 1999):

- (i) Luis exclamó que qué guapa que estaba María. (Spanish)
Luis claim-PAST-3.SG that what pretty that be-PAST-3.SG María
'Luis said that María looked really beautiful'
- (ii) Luis preguntó (que) cuándo vendrías. (Spanish)
Luis ask-PAST-3.SG that when come-COND-2.SG
'Luis asked when you would come'
- (iii) Oye, que el Madrid hace mucho que no gana una Champions. (Spanish)
listen, that the Madrid make-3.SG much that not win-3.SG a Champions
'Listen, it has been a long long time since Real Madrid does not win a Champions League'
- (iv) Si preguntan por mí, que no he venido en todo el día. (Spanish)
if ask-3.PL for me, that not have-1.SG come in all the day
'If they ask for me, tell them I have not showed up in all day'
- (v) Todo el día dale que dale. (Spanish)
all the day give-CL-to-it that give-CL-to-it
'Everyday it is the same thing and the same thing, again and again'

The most intriguing case is –in my opinion– (i) and (ii), studied at length by Bruccart (1993). A well-known (but not well understood) observation about this structure is that it is restricted to root and exclamative environments, as Bosque (1982:29) originally noted (see also Bosque 1984a: 284 and 287; and 1999: 10).

- (vi) Qué cosas (que) dice tu amigo! (Spanish)
what things (that) say-3.SG your friend
'What things your friend say!' (= your friend is nuts!)
- (vii) Qué cosas (*que) dice tu amigo? (Spanish)
what things (that) say-3.SG your friend
'What is your friend saying?'
- (viii) Es increíble qué cosas (*que) dice! (Spanish)
be-3.SG incredible what things (that) say-3.SG
'It is incredible what things he says!'

(132)

- a. [_{CP} Qué_i C pensaba Juan [_{CP} C que le había dicho ... (Spanish)
 what think-PAST-3.SG Juan that CL-to-him had-3.SG said
 ... Pedro [_{CP} C que había publicado la revista t_i]]]
 Pedro that had-3.SG published the journal
 ‘What did Juan think that Pedro had told him that the journal had published?’
- b. [_{CP} Con quién_i C sabía Juan [_{CP} C que había admitido ... (Spanish)
 with whom know-PAST-3.SG Juan that had-3.SG admitted
 ... Ana [_{CP} C que había hablado Pedro t_i]]]
 Ana that had-3.SG talked Pedro
 ‘Who did Juan know that Ana had admitted that Pedro had talked to?’

[from Torrego 1984: 108-109]

Torrego’s (1984) seminal observation was that successive cyclic movement forces inversion along the movement path of the verb by means of her *Verb Preposing Rule*.

Addressing these matters, Torrego (1984) noted that preverbal subjects in embedded clauses create a (weak) island effect. According to Torrego (1984), the order subject-verb indicates absence of *Verb Preposing*, and, consequently, absence of successive cyclic movement. Deviance in (133) was then considered to follow from a subjacency violation.

(133)

- a. *[_{CP} Qué_i C pensaba Juan [_{CP} C que Pedro le había ... (Spanish)
 what think-PAST-3.SG Juan that Pedro CL-to-him had-3.SG
 ... dicho [que la revista había publicado t_i]]]
 said that the journal had-3.SG published
 ‘What did Juan think that Pedro had told him that the journal had published?’
- b. *[_{CP} Con quién_i C sabía Juan [_{CP} C que Ana había ... (Spanish)
 with whom know-PAST-3.SG Juan that Ana had-3.SG
 ... admitido [_{CP} C que Pedro había hablado t_i]]]
 admitted that Pedro had-3.SG talked
 ‘Who did Juan know that Ana had admitted that Pedro had talked to?’

[from Torrego 1984: 108-109]

To my ear, however, Torrego’s (1984) judgments are contrived. As far as I can tell, sentences like (134) are acceptable.

- (134) [_{CP} Qué libro_i C dice María [_{CP} C que Juan ha leído t_i]]? (Spanish)
 what book say-3.SG María that Juan have-3.SG read
 ‘Which book does María say that Juan has read?’

It is true, though, that preverbal subjects interfere with long-distance construals of wh-phrases. Bruccart (1994a) and Uriagereka (1988a; 1999b) point this out in the case of *cuándo* (Eng. *when*) and *por qué* (Eng. *why*). Consider the case of *cuándo* first:

- (135)
 a. [_{CP} Cuándo C dijo María [_{CP} C que Luis había aprobado . . . (Spanish)
 when say-PAST-3.SG María that Luis had-3.SG passed
 . . . las oposiciones]]?
 the tests
 ‘When did María say that Luis had passed the tests?’
 b. [_{CP} Cuándo C dijo María [_{CP} C que había aprobado . . . (Spanish)
 when say-PAST-3.SG María that had-3.SG passed
 . . . Luis las oposiciones]]?
 Luis the tests
 ‘When did María say that Luis had passed the tests?’

[from Bruccart 1994a: 42]

As Bruccart (1994a) points out, (135a) is ambiguous: *cuándo* can receive both long and short distance readings.

(135b) is the interesting case, since here *cuándo* favors a short distance reading, as the logic of Torrego’s (1984) analysis would predict.⁷⁷ Bruccart (1994a), nevertheless,

⁷⁷ In fact, Torrego’s (1984) analysis makes a stronger claim. If non-inversion is taken to signal absence of successive cyclic movement, then (i) and (ii) differ in that the wh-phrase *Qué fotos* (Eng. *which pictures*) has skipped the intermediate SPEC-C in (ii), moving from its base position to matrix SPEC-C in ‘one fell swoop:’

(i) [_{CP} Qué fotos_i C cree Juan [_{CP} t_i C que admira Pedro t_i]]? (Spanish)

makes two relevant observations: first, this is only a tendency, since the long-distance reading in (135b) is still possible, and, second, sentences like (136), which pragmatically favor a long-distance reading, are fine:

- (136) [_{CP} Cuándo C dices [_{CP} C que María vio a Pedro]]? (Spanish)
 when say-2.SG that María see-PAST-3.SG to Pedro
 ‘When do you say that María saw Pedro?’

[from Bruccart 1994a: 42]

Consider next *por qué* (Eng. *why*). Uriagereka (1988a) observes that this wh-phrase also allows both long and short distance readings in (137):

- (137) [_{CP} Por qué_i C piensas [_{CP} C que Hitchcock adoraba a Grace Kelly]]? (Spanish)
 for what think-2.SG that Hitchcock love-PAST-3.SG to Grace Kelly
 ‘Why do you think Hitchcock adored Grace Kelly?’

[from Uriagereka 1988a: 136]

Thus, in (137), *por qué* may (but need not) be interpreted as having undergone successive-cyclic movement from the most embedded clause. The same carries over to (138), which tells us that it does not matter ‘how long’ the long-distance construal of *por qué* turns out to be:

-
- (ii) what pictures think-3.SG Juan that admire-3.SG Pedro
 ‘Which pictures does Juan think that Pedro admires?’
 [_{CP} Qué fotos_i C cree Juan [_{CP} C que Pedro admira t_i]]? (Spanish)
 what pictures think-3.SG Juan that Pedro admire-3.SG
 ‘Which pictures does Juan think that Pedro admires?’

[from Boeckx 1999a: 229]

Empirical evidence has been reported to support this. As Boeckx (1999a) observes, following direct observations by Esther Torrego, anaphor binding reinforces the ‘bypass’ analysis. According to Torrego, binding of *sí mismo* by *Juan* is impossible without inversion in the embedded clause:

- (iii) [_{CP} Qué fotos de sí mismo_{z_i/j/k} C cree Juan_j [_{CP} que admira Pedro_k t_z]]? (Spanish)
 what pictures of self same think-3.SG Juan that admire-3.SG Pedro
 ‘Which pictures of himself does Juan think that Pedro admires?’
 (iv) [_{CP} Qué fotos de sí mismo_{z_i/*j/k} C cree Juan_j [_{CP} que Pedro_k admira t_z]]? (Spanish)
 what pictures of self same think-3.SG Juan that Pedro admire-3.SG
 ‘Which pictures of himself does Juan think that Pedro admires?’

[from Boeckx 1999a: 229]

Like in (133), the contrast is not clear to me. Actually, I can get the reading Torrego dismisses.

- (138) [_{CP} Por qué C dices [_{CP} C que Juan cree [_{CP} C que Hitchcock adoraba a Kelly]]]?
for what say-2.SG that Juan think-3.SG that Hitchcock love-PAST-3.SG to Kelly
'Why do you say that Juan believes that Hitchcock adored Kelly?'

But the crucial case is (139), where long-distance reading of *por qué* is impossible (or extremely hard to get):

- (139) *[[_{CP} Por qué_i C Juan cree [_{CP} C que Hitchcock adoraba a Kelly t_i]]]? (Spanish)
for what Juan think-3.SG that Hitchcock love-PAST-3.SG to Kelly
'Why does Juan think that Hitchcock adored Kelly?'

Notice that only the matrix subject (and not the embedded ones) appears in a preverbal position this time. This is the crucial factor in blocking long-distance construal of *por qué* (Eng. *why*).⁷⁸

It seems, therefore, that Torrego's (1984) claim about preverbal subjects was not accurate, since the effects only emerge in the case of matrix clauses. This is a welcome conclusion, as it is not easy to see what the role of preverbal subjects in blocking long-distance wh-movement would be.

Within minimalism, Uriagereka (1999b) reassessed Torrego's (1984) analysis, concentrating on the interaction (actually, incompatibility) between preverbal subjects and interrogative clauses. For Uriagereka (1999b), the problem in the two examples in (140) is the same:

- (140)
a. *[[_{CP} Qué libros_i C Borges escribió t_i]]? (Spanish)
what books Borges write-PAST-3.SG
'Which books did Borges write?'

⁷⁸ A similar contrast is observed by Collins (1991: 33), who points out that, while (i) is ambiguous (*why* can be associated with both clauses), (ii) is not (*how come* only has a matrix interpretation):

- (i) Why did John say Mary left?
(ii) How come John said Mary left?

[from Collins 1991: 33]

- b. *María no sabe [CP qué libros_i C Borges escribió t_i] (Spanish)
 María not know-3.SG what books Borges write-PAST-3.SG
 ‘María does not know which books Borges wrote’

Uriagereka (1999b) compares (140) with (141), showing that preverbal subjects (here, *Jon*) block wh-extraction in Basque too:⁷⁹

(141)

- a. *Ez dakit [CP zer_i C [TP Jonek bidali t_i dion]] (Basque)
 not know-1.SG what-ABS Jon-ERG sent 3.SG-have-3.SG-if
 ‘I don’t know what Jon has sent’
- b. Ez dakit [CP zer_i C [TP *pro* bidali t_i dion]] (Basque)
 not know-1.SG what-ABS *pro* sent 3.SG-have-3.SG-if
 ‘I don’t know what has sent’

[from Uriagereka 1999b: 409]

Under Uriagereka’s (1999b) analysis, the problem with these data is not the absence of T-to-C movement (*contra* Gallego 2004a), but from T₅P being an A-related island (a barrier that emerges from morphological convergence). In particular, Uriagereka (1999b) argues that rich agreement languages induce a barrier when a lexically overt specifier forces “morphological repair” (in the sense of Chomsky 1995b: 263).

⁷⁹ Basque essentially works like Spanish: it displays obligatory inversion in marked modality contexts, with the auxiliary-lexical verb cluster (*ikusi-du*, in the examples below) moving to C.

- (i) Nor ikusi du Jonek? (Basque)
 who seen have-3.SG Jon
 ‘Who has Jon seen?’
- (ii) *Nor Jonek ikusi du? (Basque)
 who Jon seen have-3.SG
 ‘Who has Jon seen?’

[from Ortiz de Urbina 1995: 102]

These and similar structures are studied by Ortiz de Urbina (1995), where it is noted that northern Basque dialects display an English-like behavior, allowing subjects to be sandwiched between auxiliaries and lexical verbs:

- (iii) Nork du Jon ikusi? (Northern Basque)
 who have-3.SG John seen
 ‘Who has John seen?’
- (iv) Nor du Jonek ikusi? (Northern Basque)
 who have-3.SG John seen
 ‘Who has seen John?’

[from Ortiz de Urbina 1995: 105-106]

In other words: in the examples in (140), the subject *Borges* moves to SPEC-T_S before wh-movement, forcing the system to immediately transfer the structure so far constructed (i.e., the T_SP). As a result, T_SP is rendered ‘out of sight’ for computational purposes, and nothing can be extracted from it.

For my concerns here, this amounts to the claim that T_SP is a convergent domain: a *phase*. Both Uriagereka (1999b) and Gallego (2004b; 2005) therefore arrive at the same conclusion, but they do so through independent paths: for Uriagereka (1999b), T_SP is a phase due to inflectional properties of T_S (i.e., φ-features), while for Gallego (2004b; 2006), T_SP qualifies as a phase in NSLs due to its A-bar properties, as repeatedly suggested in the GB-literature .

Uriagereka’s (1999b) account builds on Chomsky’s (1995b) conception of T_S as having a D feature attracting the closer DP (the EPP₂): as a consequence of *Attract* (T, D), the DP becomes ‘morphologically incomplete’ and needs to move to a position where it can be ‘repaired:’ SPEC-T_S. As soon as that movement takes place, a morphological cycle is closed off, and a barrier emerges in rich-agreement languages. The contrast in (142) thus follows, according to Uriagereka’s (1999b).⁸⁰

(142)

- a. *No sé [CP qué_j C [TP Juan_i dijo_k T_S [v*P t_i t_k t_j]]] (Spanish)
 not know-1.SG what Juan say-PAST-3.SG
 ‘I do not know what Juan said’
- b. I do not know [CP what_j C [TP John_i T_S [v*P t_i said v* t_j]]]

Appealing as it is, Uriagereka’s (1999b) account raises some questions. To begin with, it is not entirely clear how T_SP is transferred before the merger of C and subsequent wh-movement: in Chomsky’s (2004; 2007; to appear) system, T_SP gets transferred, but C must be already in the derivational workspace.

⁸⁰ It is worth emphasizing that Uriagereka’s (1999b) proposal shares with Rizzi’s (1978; 1982) the idea that English and NSLs differ as far as bounding nodes are concerned. Most importantly, this idea is in the very spirit of *Phase Sliding* (however they should be formulated).

Another issue that deserves attention is the mysterious absence of L-related barriers when no lexical specifier appears. In those cases, a(n expletive) *pro* should arguably be merged in SPEC-T_S in order to satisfy EPP₂ (see Rizzi 1982). In this regard, Uriagereka (1999b) argues that little *pro* is just a feature, and, as such, does not qualify as a DP in need of morphological repair.

Although recent work has cast doubt on the status of little *pro*,⁸¹ it seems to me that Uriagereka's (1999b) analysis would run into problems when trying to account for why relative clauses do not trigger morphological repair. (145b), just like (145a), is fine.

(143)

- a. El hombre [_{CP} a quien_i C Juan llamó t_i]] (vs. *A quién Juan llamó?) (Spanish)
the man to who Juan call-PAST-3.SG
'The man who Juan called'
- b. El hombre [_{CP} a quien_i C llamó Juan t_i]] (vs. A quién llamó Juan?) (Spanish)
the man to who call-PAST-3.SG Juan
'The man who Juan called'

Granted, some process of "domain extension," in Chomsky's (1993a; 1995b) sense, could be postulated for relative clauses in order to restore the asymmetry. As a matter of fact, a domain extension mechanism is invoked by Uriagereka (1999b) to account for (144):⁸²

⁸¹ See, in particular Alexiadou & Anagnostopoulou (1998) and Picallo (1998), who eliminate (the role of) *pro* in Romance languages. For a different view, see Holmberg (2005). I come back to *pro* in section 7.

⁸² One more time, similar facts are found in Italian, as noted by Cardinaletti (2001a), following Rizzi (1996):

- (i) ??Tutti si domandano che cosa il direttore ha detto. (Italian)
all SE wonder-PAST-3.PL what thing the director have-3.SG said
'Everybody wondered what the director has said'
- (ii) Tutti si domandano che cosa il direttore abbia detto. (Italian)
all SE wonder-PAST-3.PL what thing the director have-SUBJ-3.SG said
'Everybody wondered what the director have said'

[from Cardinaletti 2001a: 13]

The Spanish variety spoken in Spain lacks this pattern in a generalized fashion, since it lacks embedded interrogatives in subjunctive mood (see section 3.4.).

As Suñer (1999: 2184-2185) points out, subjunctive mood in embedded questions was frequent in old Spanish and it still is in some northern varieties of Spain, in Perú, and in Colombia. The example in (iii), for instance, can be found in those non-European varieties.

- (iii) *No sé qué yo le diga. (Spanish)

(144)

- a. Non sei [CP qué C (*ti ou eu) lle enviamos] (Galician)
 not know-1.SG what C (you or I) CL-to-him send-PAST-1.PL
 ‘I do not know what we sent him’
- b. Non sei [CP qué C (ti ou eu) lle enviemos] (Galician)
 not know-1.SG what you or I CL-to-him send-SUBJ-1.PL
 ‘I do not know what we could send him’

[from Uriagereka 1999b: 441]

But even though Uriagereka’s (1999b) analysis can tackle (144), it cannot easily explain the asymmetry in (145), where inversion is prevented through wh-phrases pied-piping a preposition:⁸³

(145)

- a. (?) [CP Con qué compañías_i C [TP Rebeca no trabajaba t_i]]? (Spanish)
 with what companies Rebeca not work-3.SG
 ‘What companies does not Rebeca work with?’
- b. (?) [CP Para qué empresas_i C [TP Rebeca no trabaja t_i]]? (Spanish)
 for what companies Rebeca not work-3.SG
 ‘What companies does not Rebeca work for?’

This said, I hasten to add that I have not provided an explanation to the fact that long-distance construal of *por qué* (Eng. *why*) in (139), repeated below as (146), is impossible.

not know-1.SG what I CL-to-him say-SUBJ-1.SG
 ‘I do not know what I tell him’

The closest translation in my idiolect resorts to a modal, but things do not improve, as inversion is needed too:

- (iv) *No sé qué yo podría decirle. (Spanish)
 not know-1.SG what I could-1.SG tell-INF-CL-to-him
 ‘I do not know what I could tell him’

⁸³ For a general review of Uriagereka’s (1999b) analysis, I refer the reader to Cardinaletti’s (2001a; 2004; 2006) work.

- (146) *_{[CP Por qué_i C Juan cree [_{CP} C que Hitchcock adoraba a Kelly t_i]]} (Spanish)
 for what Juan think-3.SG that Hitchcock love-PAST-3.SG to Kelly
 ‘Why does Juan think that Hitchcock adored Kelly?’

To recap so far, I have been defending that Pesetsky & Torrego’s (2001) ideas about T-to-C in English naturally extend to NSLs. Yet, in Gallego (2003; 2004a) I noted that some facts make English and Spanish differ. In particular, subjects in Spanish behave differently, since they do not appear to be able to value C’s T. The facts in (147), (148), and (149), where subjects cannot move to SPEC-C, illustrate this point:

(147) *Embedded declarative clauses*

- a. Mary says [_{CP} C_[TNOM] that_i_[TNOM] [_{TP} John does T_{Si}_[TNOM] not work]]
 b. Mary says [_{CP} John_i_[TNOM] C_[TNOM] [_{TP} t_i does T_{Si}_[TNOM] not work]]
 c. La Maria diu [_{CP} C_[TNOM] que_i_[TNOM] [_{TP} en Joan T_{Si}_[TNOM] no treballa]] (Catalan)
 the Maria say-3.SG that the Joan not work-3.SG
 ‘Maria says that Joan does not work’
 d. *La Maria diu [_{CP} en Joan_i_[TNOM] C_[TNOM] [_{TP} t_i T_{Si}_[TNOM] no treballa]] (Catalan)
 the Maria say-3.SG the Joan not work-3.SG
 ‘Maria says Joan does not work’

(148) *Embedded interrogative clauses*

- a. I don’t know [_{CP} what_i C_[TNOM] [_{TP} Mary_[TNOM] T_S says t_i]]
 c. No sé [_{CP} què_i C_[TNOM] diu_k_[TNOM] [_{TP} la Maria_[TNOM] t_k t_i]] (Catalan)
 not know-1SG what say-3.SG the Maria
 ‘I don’t know what Mary says’
 b. *No sé [_{CP} què_i C_[TNOM] [_{TP} la Maria_[TNOM] T_S diu t_i]] (Catalan)
 not know-1.SG what the Maria say-3.SG
 ‘I don’t know what Mary says’

(149) *Relative clauses*⁸⁴

- a. The man [CP who_i[T_{NOM}] C_[T_{NOM}] [TP t_i T_S [t_i called John]]]
 b. *El hombre [CP quien_i[T_{NOM}] C_[T_{NOM}] [TP t_i T_S llamó a Juan]] (Spanish)
 the man who call-PAST-3.SG to Juan
 ‘The man who called Juan’

In Gallego (2004b) I suggested to relate the fact that subjects cannot check C’s T to two well-known traits of NSLs: the lack of both *that*-trace effects and *that*-deletion.⁸⁵

(150) *that*-trace & *that*-deletion

- a. [CP Chi_i credi_j[T_{NOM}] C_[T_{NOM}] [TP pro t_j [CP t_i C_[T_{NOM}] che_k[T_{NOM}] [TP t_i T_{Sk}[T_{NOM}] parla]]]? (Italian)
 who think-2.SG that talk-3.SG
 ‘Who do you think has talked?’
 b. *En Lluís diu [CP la Maria_i[T_{NOM}] C_[T_{NOM}] [TP t_i T_S[T_{NOM}] no vindrà]] (Catalan)
 the Lluís say-3.SG the Maria not come-FUT-3.SG
 ‘Lluís says Maria will not come’

Gallego’s (2004b) solution to these asymmetries capitalized on Uribe-Etxebarria’s (1992) hypothesis that, subject DPs in Spanish receive nominative Case in SPEC-*v**, a process that is generally taken to happen in SPEC-T_S in English; see Boeckx 2003b; 2006b).

⁸⁴ See Gallego (2006b) for a T-to-C movement analysis of relative clauses which reinforces the syntactic inertness of subjects’ T feature in NSLs.

⁸⁵ Some comments are in order. First, as Rizzi (1997) noted, topicalized constituents ameliorate *that*-trace effects (see Pesetsky & Torrego 2001):

- (i) Mary is claiming that ??(for all intents and purposes) John is the mayor of the city.
 (ii) Mary know that ??(books like this) Sue will enjoy reading.

[from Pesetsky & Torrego 2001: 375]

Second, as is well-known, French presents a sort of *that*-trace effect which forces the complementizer to be spelled-out as *qui* (see Rizzi 1990 for the basic facts and Rizzi & Shlonsky 2007 for updated discussion):

- (iii) Qui_i veux-tu que Marie épouse t_i? (French)
 who want-you that Marie marry-3.SG
 ‘Who do you want Marie to marry’
 (iv) Qui_i veux-tu {*que/qui} t_i épouse Jean? (French)
 who want-you that/that marry-3.SG Jean
 ‘Who do you want to marry Jean?’

Gallego (2004b) recasts Uribe-Etxebarria's (1992) proposal by claiming that T_SP is the first phase –a claim consistent with different observations gathered from the GB literature and, crucially, with *Phase Sliding*.

The key consequence of T_SP counting as a phase is that the T feature of subjects is deleted before the CP phase starts. Having been deleted sooner, the T feature of subjects 'dies' sooner. Graphically, the contrast between English and NSLs with respect to the interaction between C and the T feature of subjects is as pictured below:

(151) English

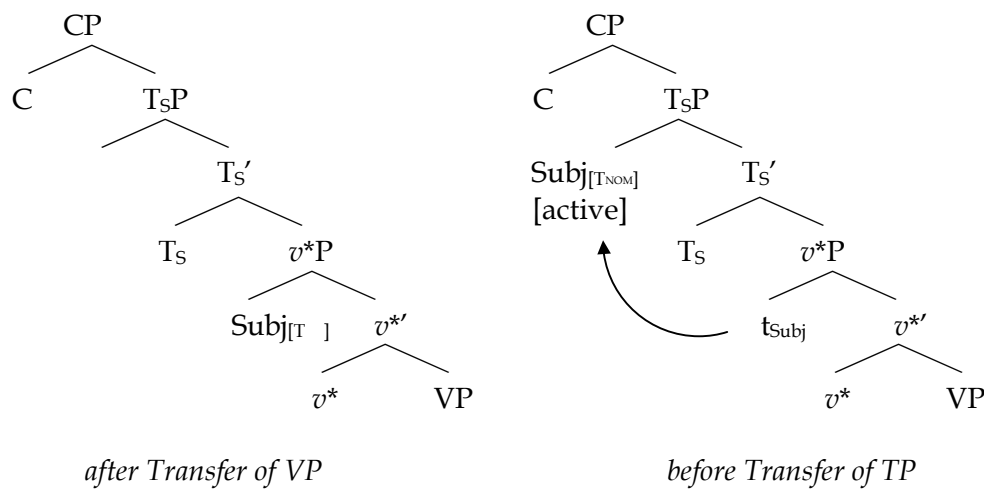

(152) Null Subject Languages

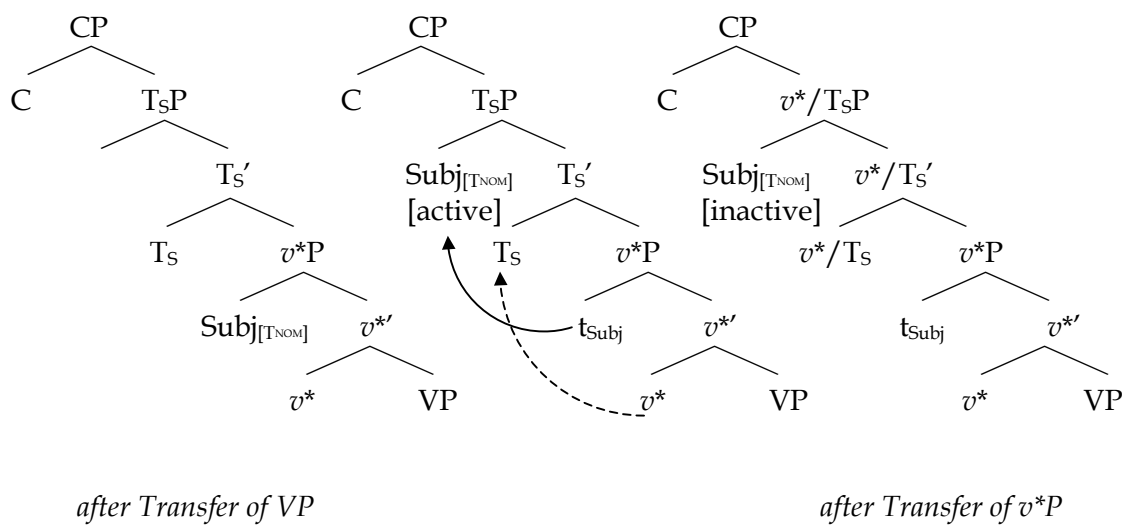

Notice that the analysis entertains Pesetsky & Torrego's (2001) distinction between being 'marked for deletion' and 'deleted' (akin to Chomsky's 1995b 'deletion'/'erasure'): uninterpretable features are marked for deletion (i.e., valued) upon Agree, but they do not delete until the phase level is reached. Gallego (2004b) assumes (153), which is similar to the *Phase Condition*, to capture the relevant parameter.

(153) **TIMING OF DELETION OF UNINTERPRETABLE FEATURES**

An uninterpretable feature uF marked for deletion within a completed phase [Ph] is deleted the moment a new head [H] is merged to [Ph]

[from Pesetsky & Torrego 2004: 516]

Let me insist here in what I already discussed in section 2.3., namely, the fact that Pesetsky & Torrego's (2001; 2004) deletion mechanism is different from Chomsky's (2001; 2004; to appear). As the reader may recall, Pesetsky & Torrego (2001; 2004) argue that uninterpretable features can live only within the phase in which they have been valued –the system, therefore, can make use of them during that period of time, but it must also be able to 'remember' that they started being unvalued, so that deletion eventually occurs.

Though of course not necessary, something like (153) is very plausible: the basic idea relies on the existence of the *Phase-Level Memory*, as argued in chapter 1, which can keep track of computational business (in the case at hand, feature valuation). Crucially, Chomsky's (2004) Transfer is not invoked, and, more importantly, uninterpretable features do not have to be downloaded to specific domains for deletion to take place

Gallego's (2004b) idea that T_SP is a phase is here translated into *Phase Sliding*: T_SP is not a phase, *v*^{*}/T_SP is, by means of the extra Transfer. Such a state of affairs, however, has non-trivial consequences. The most important drawback *Phase Sliding* has to face was already mentioned: if *Phase Sliding* is triggered from above (by C), how is it possible for nominative Case to be assigned within the first phase (*v*^{*}/T_SP)?

Notice that this problem would not arise if I had assumed that *v*^{*}-to-T movement takes place leaving C aside, but that possibility is problematic. As suggested in the

previous section, this shortcoming goes away if there are three applications of Transfer.⁸⁶ After v^* 's complement domain (the VP) is transferred, the CP is activated; exactly at that point, C establishes Multiple Agree with T_S and v^* , nominative Case is assigned to the subject and v^* -to-T movement takes place. Crucially, v^* -to-T movement triggers *Phase Sliding*, which causes deletion (erasure, if you want) of the subject's T feature.

Let us momentarily put this discussion aside and return to the facts regarding interrogative sentences (i.e., obligatory inversion, T-to-C movement, and so on). As we saw, *wh*-phrases introduced by (some) prepositions may prevent T-to-C movement. The relevant data are those in (127), repeated here as (154):

(154)

- a. [_{CP} Por qué_i C [_{TP} Celia llamó a su hermana t_i]]? (Spanish)
 for what Celia call-PAST-3.SG to her sister
 'Why did Celia call her sister?'
- b. ?[_{CP} En qué medida_i C [_{TP} la Constitución ha contribuido a esto t_i]]? (Spanish)
 in what measure the Constitution have-3.SG contributed to that
 'To what extent has the Constitution contributed to that?'
- c. ?[_{CP} Con cuánto dinero C [_{TP} el Gobierno te ha premiado t_i]]? (Spanish)
 with how-much money the Government CL-you have-3.SG rewarded
 'With how much money has the Government rewarded you?'

Gallego (2004b) accounts for these facts by arguing that prepositions can take care of checking *C*'s T. This is so because, by the logic of Phase Sliding, *wh*-phrases stop at SPEC- v^*/T before the v^*P is transferred: because of that, *wh*-phrases are always closer to C than T_S itself.

Consider this hypothesis with the specific example in (155), where the *wh*-phrase *hasta qué punto* (Eng. *how much*) prevents T-to-C movement in the embedded clause.

⁸⁶ Of course, more alternative solutions come to mind, none of them compatible with Chomsky's orthodox *Phase Theory*. Given that I want to assume only what I cannot dispense with, I will not speculate here.

- (155) No imaginas [_{CP} hasta qué punto_i C Germán me ha ayudado t_i] (Spanish)
 not imagine-2.SG to what point Germán CL-me have-3.SG helped
 ‘You cannot imagine how much Germán has helped me’

As (156) shows, *hasta qué punto* is indeed closer to C than *v*/T_S* itself: this is -I
 claime- what accounts for the paradigm in (154):

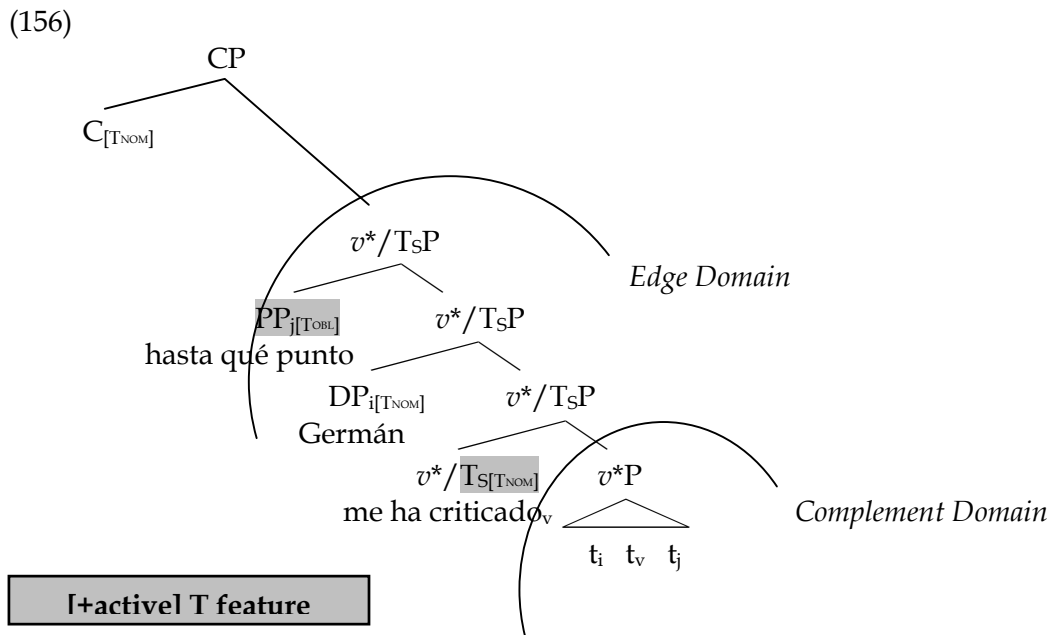

A completely different scenario obtains in English. Consider the examples in (157),
 where although all the wh-phrases pied-pipe a preposition, ungrammaticality obtains
 if *do* is not inserted.

- (157)
- a. [_{CP} In which city_i C *(does)_j [_{TP} Susan T_j work t_i]] ?
- b. [_{CP} For which company_i C *(do)_j [_{TP} you T_j work t_i]] ?
- c. [_{CP} With how many people_i C *(did)_j [_{TP} you T_j go to Boston t_i]] ?

Given the lack of *Phase Sliding*, the wh-phrases in (157) end up in SPEC-*v** before C
 starts any scanning procedure. As a consequence, T_S (and the subject) is always closer
 to C than the P present in these wh-phrases, so T-to-C movement cannot be skipped.

(158)

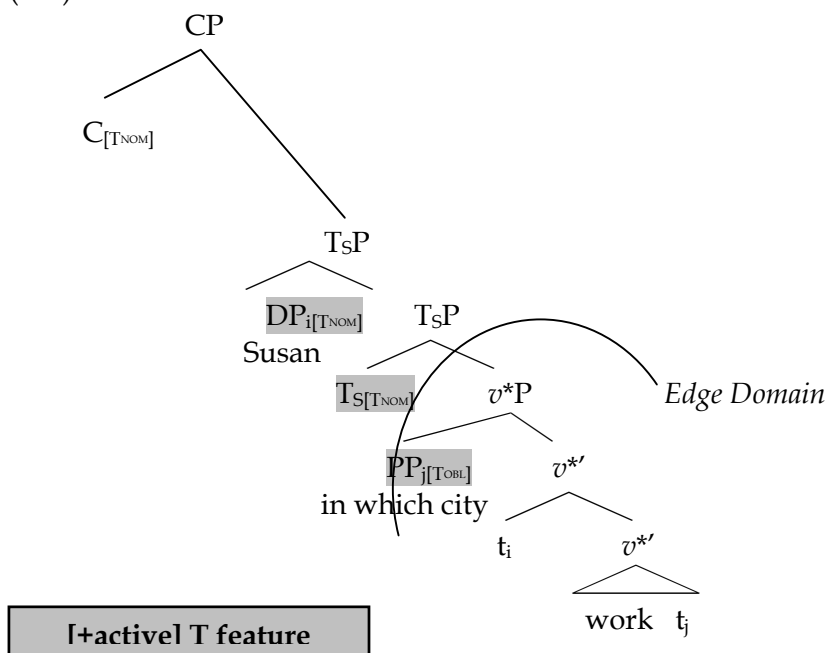

In this section I have assessed some consequences of *Phase Sliding* for the syntax of NSLs. I have delved into two main issues: obligatory inversion in interrogative clauses (and the possibility for some wh-phrases to prevent it) and the interaction between islandhood and preverbal subjects. Following Gallego (2004a), I have put forward a T-to-C analysis for obligatory inversion along the lines of Pesetsky & Torrego's (2001; 2004) system, arguing that there is only one type of wh-dependent which can prevent verb movement: wh-phrases pied-piping certain kinds of prepositions. I have also noted that obligatory inversion is in fact not obligatory –it can fail, but not for free: if the verb does not move to C, a semantic effect obtains. As for the effects created by preverbal subjects, both Torrego's (1984) and Uriagereka's (1999b) analysis have been rejected: preverbal subjects force neither subjacency violations nor the Spell-out of T₅P. There is nothing, in sum, especially deep about preverbal subjects (apart, of course, from their discourse-oriented interpretation), but there is something special about subjects in general in NSLs: because of *Phase Sliding* and the additional Transfer it triggers, their T feature can never be used to delete C's T.

6. Conclusions

This chapter has explored a hypothesis concerning parametric variation that accounts for important locality and structure properties of NSLs. The proposal clearly revamps Chomsky's (1986a) analysis of V-movement as a device to proper L-mark, an intuition that has been presented in the GB literature in one form or another, either suggesting that NSLs's INFL is a proper governor of the subject or the VP (see Jaeggli 1984, Kayne 1989, and Lasnik & Saito 1992), or that SPEC-INFL has both A and A-bar properties in NSLs (see Barbosa 1995, Camacho 2005, Goodall 1993; 1999; 2000, Fortuny 2007, Masullo 1992, and Myriam Uribe-Etxebarria 1992), or else that bounding nodes are different cross-linguistically (see Rizzi 1978; 1982 and Sportiche 1981).

In the present formulation, I have claimed that T_S has phase properties in NSLs without giving up the leading role of *v** and C. Specifically, I have claimed that T_S becomes phasal by means of *v**-to-T movement, forcing a parametrized application of Transfer (see Uriagereka 1999b).⁸⁷ For that scenario to be possible, I have assumed that *v**-to-T movement is truly syntactic, forcing a reprojection of T_SP which redefines locality properties (metaphorically speaking, *v**'s movement pushes up the *v**P phase to the T_SP level, causing what I have called *Phase Sliding*). The main consequence of *Phase Sliding* concerns uninterpretable morphology (Case/T), which –I have assumed– has a phase-based lifespan (the *Phase Condition*).

If on track, the proposal may perhaps explain not only why subjects's T feature cannot undergo Agree dependencies with C, but also why most NSLs lack *v**P ellipsis and *v**P topicalization (but see Vicente 2007), or why Laka's (1990) Σ is projected above T_SP in NSLs, while above *v**P in English.

⁸⁷ The process is analogous to Den Dikken's (2006; 2007) *Phase Extension*, a mechanism whose specifics I cannot address here.

CHAPTER III

PARAMETRIC VARIATION IN ROMANCE

1. Introduction

The previous chapter concentrated on the notion of *phase* and the possibility that head movement of v^* give rise to a second, parametrized, Transfer to the interface components, in the spirit of Uriagereka's (1999b) proposal about islands in rich agreement languages. I called the trigger *Phase Sliding*.

(1) PHASE SLIDING

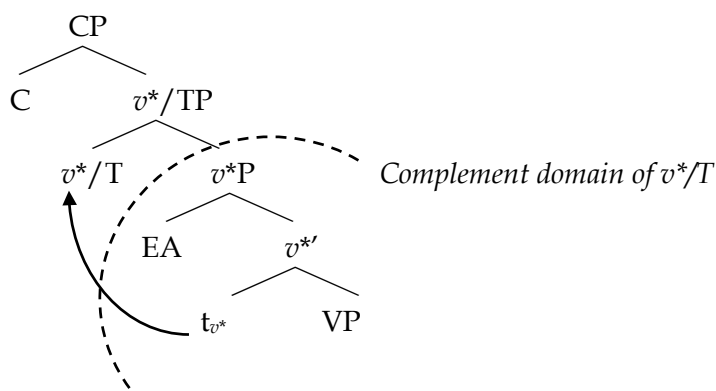

I argued that the process depicted in (1) is due to morphological reasons, and tried to establish a connection between it and the special behavior of subjects when it comes to Case checking –with critical consequences for extraction (i.e., *that*-trace effects and *that*-deletion). Adopting Pesetsky & Torrego's (2001; 2004; 2007) apparatus, I captured the special status of subjects in NSLs proposing that their T feature is inactive/inert by the time C wants to interact with them.

These issues directly bear on the *pro drop* nature of NSLs and should therefore be viewed as the consequences of a "macro-parameter" (see Baker 2001; 2003 and Kayne 2000).

In this chapter, I plan to keep on discussing aspects of Romance languages in the context of Chomsky's *Phase Theory*. Likewise, I will keep on arguing that the most compelling argument for having phases comes from the Phase Condition, introduced in chapter 2 and repeated below:

(2) PHASE CONDITION

Uninterpretable morphology is phase bounded

In what follows I want to focus on the the 'hot'/'active' left-peripheral behaviour of NSLs, associated to Uriagereka's (1995a; 1995b) FP projection, which presents two discrete parameters: one syntactic (and therefore of the 'macro' type), the other morphological (hence qualifying as 'micro').

As will be shown, the parameters give raise to a species of *continuum* that goes from highly conservative NSLs like European Portuguese and Galician (showing bizarre left-peripheral phenomena, such as overt focus heads, inflected infinitivals, complex clitic clusters, etc.), to radical ones like French –not an NSL, actually, hence lacking generalized left-peripheral affective constructions.

I will suggest that, in NSLs, a 'morphologically rich T' may subsume the syntax-pragmatics interface role played by Uriagereka's (1995a; 1995b) F, a hypothesis that naturally carries over to those clausal structures that, in Uriagereka's (1995a; 1995b) terms, do not have an active F (i.e., non-finite clauses), being therefore unable to exploit generalized left-peripheral fronting.

After reviewing all the data, I will arrive at the following conclusion: C and v^* appear to go hand in hand with respect to peripheral activity cross-linguistically –that is, languages that show an 'active' CP periphery (see Rizzi 1997; 2004; 2006), have an 'active' v^* P periphery (see Belletti 2004), a fact I trace to morphological richness, in a sense I will clarify in the following sections.

The chapter is divided as follows: section 2 explores the *Left Periphery* of Romance languages, trying to recast the findings of Uriagereka (1995a; 1995b); section 3 discusses the status of T_{def} in NSLs, offering an analysis of indicative and subjunctive

embedded clauses; section 4 tries to reinforce the claim made in section 3 by showing that preverbal subjects –as already pointed out by much of the GB literature– behave as a species of topic (in particular, preverbal subjects will be argued to be the result of what we could call a *Subject Shift*, with a semantic effect ensuing); in section 5, building on original observations by Ordóñez (1998b), I argue that Spanish VOS order involves movement of the object DP to a specifier position c-commanding the subject DP, a position I identify as an outer-SPEC- v^* ; finally, section 6 concentrates on the EPP₂ (the requirement for SPEC-T to be filled in), assessing its status in NSLs.

2. Uriagereka's (1995a; 1995b) "F" and Parametric Variation

Building on work by Rigau (1993; 1995) and Uriagereka (1995a; 1995b; 1999b), this section provides evidence reinforcing the claim that T_S displays properties unexpected under orthodox formulations of *Phase Theory*. I report basic empirical facts concerning a micro-parametric cut that has what Uriagereka (1995a; 1995b) called FP as its locus. To be precise, I argue that Uriagereka's F shows more active syntactic effects the more we move to western Romance varieties, a situation I want to relate to morphological tense richness.

Let us begin by going back to the macro-parameter affecting T_S in NSLs argued for in the previous chapter. There are various ways to proceed, all we have to make sure is that v^*/T_{SP} counts as a transfer point in NSLs so that nominative Case becomes useless when C is to check its T feature. Regardless of the details, the choice should be compatible with (3), repeated from chapter 2 (section 4):

(3) PARAMATER SETTING ASSUMPTION

Parametrical variation is restricted to phase heads C and v^*

The assumption in (3) is telling us that even though T_S appears to be the locus of parametric options, it should not: actually, it is v^* or C that should make T_S special. Notice that a parameter like this (however we formulate it) has many consequences, one of which being that most of the facts that typically involve Rizzi's (1997) *Left Periphery* might turn out to involve v^*/T_{SP} instead.

From the point of view of orthodox *Phase Theory*, there are two mechanisms that could obtain the desired results: feature-inheritance from C in analytic or syncretic modes, as indicated in (3). The analytic mode could give rise to the so-called cartographies, whereas the syncretic one could be captured by Uriagereka’s (1995a; 1995b) FP, a projection sandwiched between C and T_S that encodes discourse-oriented effects.¹

(4)

a. *Cartography*

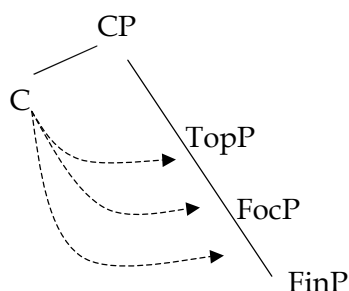

b. *F Projection*

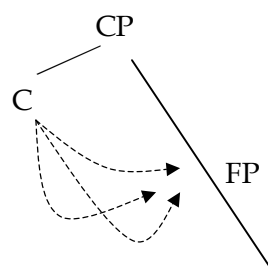

Similar ideas have been defended in the case of *v**P, with different functional projections hanging around the phase head *v** (see Belletti 2004 and Cinque 1999).

Of particular interest in the context of parametric variation and *Phase Sliding* is the question of whether there is any connection between verb movement and the possibility of having more peripheral activity (or, alternatively, in being a ‘hot’ language, in Huang’s 1982 terms).

Following the GB literature (see Pollock 1989, Rizzi 1982, Taraldsen 1980, and Uriagereka 1988a, among others), I will assume so, arguing that the role played by peripheral projections can be subsumed by *v**-to-T_S movement under *Phase Sliding*.

At this point, Uriagereka’s (1995a; 1995b) reasoning about the syntactic and morphological parameters associated to F falls into place: French and

¹ See Raposo & Uriagereka (2005) for empirical and conceptual arguments against a cartographic approach. For much discussion about analytic and syncretic modes see Fortuny (2007).

Galician/E.Portuguese occupy the two opposite poles of what one might call the “F parameter.”

(5) **THE F PARAMETER**

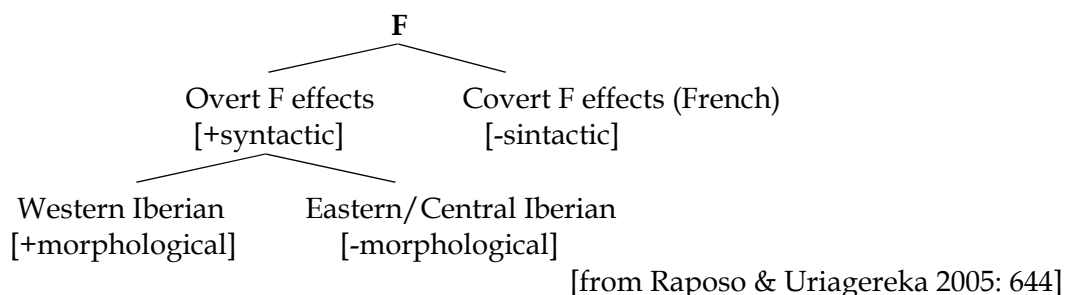

Most crucially, I would like to defend (6) as the trigger of (5):

(6) **I(h)M - ϕ CORRELATION (non-final version)²**

I(h)M is parasitic on the richness of the ϕ -system

The *I(h)M- ϕ Correlation* in (6) claims that a T_S which is morphologically richer can exploit I(h)M in a more active fashion (and, by parity of reasoning, also claims that we do not expect to find a phase head with poor morphology displaying ‘hot’ peripheral activity).

I think (6) has two additional advantages: first, it reinforces Chomsky’s idea that morphology is not an imperfection, and second, it captures the fact that non-finite clauses tend to disallow fronting-like operations (see Raposo & Uriagereka 2005). The latter observation can be seen in (7) and (8):³

(7) *Finite clauses: ‘active’ peripheral fronting*

a. Luis dice que, los libros_i, ya los_i leyó. (Spanish)

Luis say-3.SG that, the books, already CL-them read-3.SG

‘Luis says that the books he already read’

² I am using the letter “ ϕ ” here as a cluster for all types of morphological information the C-T-*v** spine can manifest. As argued below, tense inflection is the most important feature for (6).

³ Under Rizzi’s (1994; 1997; 2001a; 2004; 2006) articulated system, the contrast between (7) and (8) is usually explained in terms of ‘truncation,’ a series of projection being missed in the CP layer.

b. Luis dice que CERVEZA ha bebido (y no sidra). (Spanish)
Luis say-3.SG that BEER have-3.SG drunk (and not cider)

‘Luis says that BEER he has drunk (and not cider)’

c. Vi a Luis leyendo los libros. (Spanish)

see-PAST-1.SG to Luis reading the books

‘I saw Luis reading the books’

(8) *Non-finite clauses: ‘weak’ peripheral fronting*

a. ??Luis quiere, los libros, leerlos. (Spanish)

Luis want-3.SG, the books, read-INF-CL-them

‘Luis wants the books to read them’

b. *Luis quiere CERVEZA beber (y no sidra). (Spanish)

Luis want-3.SG BEER drink-INF (and not cider)

‘Luis wants BEER to drink (and not cider)’

c. *Vi a Luis, los libros, leyéndolos. (Spanish)

see-PAST-1.SG to Luis, the books, reading-them

‘I saw Luis the books reading them’

To capture these asymmetries we do not need to argue that T_S carries Raposo & Uriagereka’s (2005) [+affective] feature (or any of Rizzi’s criterial marks, for that matter): all we need is for T_S to have an overtly rich morphological endowment.

Some empirical evidence casts doubt on this idea, though, for although all NSLs display v^* -to-T movement, not all NSLs have the same exotic peripheral behaviour. Actually, some NSLs behave more like non-finite clauses or morphologically poor languages, like English.

As Raposo & Uriagereka (2005) argue, in the most conservative NSLs (i.e., E.Portuguese and Galician), F can show bizarre patterns involving overt focus heads, inflected infinitives, and complex of clitic clusters.

As for Spanish (and related languages), although it has an active periphery, it is not as strong as Galician’s or E.Portuguese’s, but it still allows more fronting than

Catalan's. This is shown in the following examples, which illustrate a type of mild focalization very common in Spanish.⁴

(9)

- a. Por algo será. (Spanish)
 for something be-FUT-3.SG
 'It must be for some reason'
- b. Hablé con Inés y poco más he hecho, la verdad. (Spanish)
 talk-PAST-3.SG with Inés and few more have-1.SG done, the truth
 'I talked to Inés but I did not do many more things, to be honest'
- c. Para mí querría yo esos problemas! (Spanish)
 for me want-COND-1.SG I those problems
 'I wish all I had to worry about was that!'
- d. Poco dinero es ese, creo yo. (Spanish)
 few money be-3.SG that, think-1.SG I
 'That is not much money, I think'
- e. Mucha tontería dices. (Spanish)
 much crap say-2.SG
 'You say a lot of crap'
- f. En bonito lío me he metido! (Spanish)
 in pretty problem CL-me have-1.SG got-into
 'What a big trouble I am in!'
- g. Muy rica está la sopa.⁵ (Spanish)
 very good be-3.SG the soup
 'This soup tastes really good'
- h. Buena la has hecho! (Spanish)
 good CL-it have-2.SG done
 'You have made a big mistake'

⁴ See Haegeman (2002) and subsequent work for a similar dichotomy affecting *central* and *peripheral* adverbial clauses. Contrary to the cases studied by Haegeman (2002), which are, by and far, uniform cross-linguistically, the data I am focusing on has a parametric nature.

⁵ The examples (9f) and (9g) are taken from Hernanz (2001: 103; 2003: 17). The second example is judged as ungrammatical by this scholar, but I think it is fine under the mild affective focus interpretation I am exploring here.

- i. Pues pronto empieza tu hijo... (Spanish)
then soon start-3.SG your son
'Your soon starts very soon (doing something)'
- j. Así lo quieres, así lo tienes. (Spanish)
this-way CL-it want-2.SG, this-way CL-it have-2.SG
'You want it like that, you have it like that'
- k. Si algo vieron, no lo dirán.⁶ (Spanish)
if something see-PAST-3.PL not CL-it say-FUT-3.PL
'If they saw something, they will not tell'
- l. Lo quieres? Pues en tus manos está. (Spanish)
CL-it want-2.SG Then in your hand be-3.SG
'Want it? It is in your hands'

None of the examples in (9) is accepted in a word-by-word Catalan translation.⁷

(10)

- a. *Per alguna cosa deu ser. (Catalan)
for some thing must-3.SG be-INF
'It must be for some reason'
- b. *Vaig parlar amb la Inés i poc més he fet, la veritat. (Catalan)
AUX-1.SG talk-INF with the Inés and few more have-1.SG done, the truth
'I talked to Inés and I did not do many more things, to be honest'
- c. *Per a mi voldria jo aquests problemes! (Catalan)
for to me want-COND-1.SG I these problems
'I wish all I had to worry about was these problems!'
- d. *Pocs diners són aquests, crec jo. (Catalan)
few money be-3.SG those think-1.SG I
'That is not much money, I think'
- e. *Molta ximpleria dius. (Catalan)
Many crap say-2.SG
'You say a lot of crap'

⁶ Examples like (9j) (9k) have been reported in south peninsular Spanish.

⁷ The sentences in (10) may sound better to native speakers of Spanish that also speak Catalan, like myself. For native speakers of Catalan, this pattern is just impossible.

- f. *En bonic embolic m'he ficat! (Catalan)
 in pretty problem CL-me-have-1.SG got-into
 'I am in really big trouble'
- g. *Molt bona està la sopa. (Catalan)
 very good be-3.SG the soup
 'The soup tastes really good'
- h. *Bona l'has fet! (cf. L'has fet(a) bona) (Catalan)
 good CL-it-have-2.SG done (cf. CL-it-have-2.SG done(FEM) good-FEM.SG
 'You have made a big mistake'
- i. *Doncs aviat comença el teu fill. (Catalan)
 then soon start-3.SG the your son
 'Your son starts very soon (doing something)'
- j. *Així ho vols, així ho tens. (Catalan)
 this-way CL-it want-2.SG, this-way CL-it have-2.SG
 'You want it like that, you have it like that'
- k. *Si alguna cosa van veure, no ho diràn (pas). (Catalan)
 if some thing AUX-3.SG see-INF not CL-it say-FUT-3.PL neg
 'If they saw something, they will not tell'
- l. *Ho vols? Doncs, a les teves mans està. (Catalan)
 CL-it want-2.SG Then at the your hands be-3.SG
 'Want it? It is in your hands'

To repeat, the examples in (10) do not involve contrastively focused XPs, but a milder type of focus fronting which is common (and kind of affective) in Spanish, but impossible in Catalan. The judgments are clear.

The type of focus witnessed in (9) was, to my knowledge, first noted by Torrego (1980) in examples like (11a). As Uriagereka (1988a) points out, (11a) is fully out in English:

(11)

- a. Mi abuela dice [_{CP} que muchas bobadas_i hace el Gobierno t_i]] (Spanish)
my grandmother say-3.SG that many silly-things do-3.SG the government
'My grandma says that the government does a lot of crap'
- b. *My grandma says [_{CP} that a lot of crap_i the government does t_i]]

[from Uriagereka 1988a: 100]

A good paraphrase of (11a) is (12b), good in both Spanish and in English, as Uriagereka (1988a) notes. Consequently, the relevant cut has to do with whether a given language can use the type of leftward-focalization in (11).⁸

(12)

- a. Muchas chorradas dice el Gobierno. (Spanish)
many silly-things say-3.SG the government
'The government says a lot of crap'
- b. El Gobierno dice MUCHAS CHORRADAS. (Spanish)
the government say-3.SG MANY SILLY-THINGS
'Government says a lot of crap'

[from Uriagereka 1988a: 101]

Uriagereka (1988a) further observes that this mild focus position is compatible with certain wh-words, like *por qué* (Eng. *why*), a fact he takes to suggest the existence of FP.

- (13) Ella se pregunta [_{CP} por qué_j C [_{FP} tanta chorrada_i F dirán t_i t_j]] (Spanish)
she SE wonder-3.SG for what so-much crap say-FUT-3.SG
'She wonders why they have to say so much crap'

[from Uriagereka 1988a: 101]

I agree with Uriagereka's judgment in (13), but not with its technical implementation. Instead of movement to SPEC-F, I want to argue that whereas *por qué* (Eng. *why*) occupies SPEC-C, *tanta chorrada* (Eng. *so much crap*) occupies SPEC-T_s. If

⁸ It could be argued that the focalization strategies displayed in (11) are different in terms of contrastivity. See Irurtzun (2007) for arguments against the contrastive vs. non-contrastive focus distinction.

there was an independent projection between CP and T_SP, then it is not obvious how to rule (14) out.

- (14) *Ella se pregunta [_{CP} dónde_j C tantas gilipolleces_i habrán dicho t_i t_j] (Spanish)
 she SE wonder-3.SG where so-many silly-things have-FUT-3.SG said
 ‘She wonders where they must have said so much crap’

To my ear, (14) is out, a fact I attribute (as I did in chapter 2) to lack of T-to-C movement. Importantly, (15) is also out when the subject is in a preverbal position. This suggests that the position targeted by *muchas bobadas* (Eng. *a lot of crap*) in (11a) is indeed different from both SPEC-C and Uriagereka’s (1995a; 1995b) SPEC-F: it is SPEC-T_S, the landing site of preverbal subjects.⁹¹⁰

- (15) ??Ella se pregunta [_{CP} dónde_j C Luis habrá dicho tanta gilipollez t_j] (Spanish)
 she SE wonder-3.SG where Luis have-FUT-3.SG said so-much silly-thing
 ‘She wonders where Luis must have said so much crap’

The picture is complicated when subject placement is considered throughout. I have just argued that both mildly focalized XPs and preverbal subjects compete for the same position (namely, SPEC-T_S), but this poses a micro-parametric concern: on the one hand, Spanish and Catalan allow preverbal subjects rather freely, as (16) shows, but only the former warrants mild focalization.

- (16)
 a. [_{CP} C [_{TP} Aritz T_S trabaja en Bayona]] (Spanish)
 Aritz work-3.SG in Baionne
 ‘Aritz works in Baionne’

⁹ In Uriagereka’s (1995a; 1995b) analysis (see also Raposo & Uriagereka 1996) preverbal subjects occupy not SPEC-T_S, but his SPEC-F: this would explain why mild foci are incompatible with preverbal subjects.

(i) ??/*Mucha tontería el Gobierno dice. (Spanish)
 much crap the Government say-3.SG
 ‘Government says lot of crap’

¹⁰ For related ideas, see Zubizarreta (1998: 99-117; 2007).

- b. [_{CP} C [_{TP} L' Aritz T_S treballa a Baiona]] (Catalan)
the-Aritz work-3.SG in Baionne
'Aritz works in Baionne'

My point is: if both preverbal subjects and mildly focused constituents in (9)-(10) move to the same position, how come Spanish and Catalan behave in such a different way? This is not expected under anything I said so far.

An important piece to the puzzle is provided by verb movement, which seems to be more active in Spanish than in Catalan. For instance, Spanish can marginally generate conditional inversion sentences such as the following one (see Embick & Iatridou 1994 and Hernanz 1994):

(17)

- a. Tuviera Jordi más dinero y se compraba un coche. (Spanish)
have-SUBJ-PAST-3.SG Jordi more money and SE buy-PAST-3.SG a car
'If Jordi had more money he would buy a car'
- b. *Tingués en Jordi més diners i es comprava un cotxe. (Catalan)
have-SUBJ-PAST-3.SG the Jordi more money and SE buy-PAST-3.SG a car
'If Jordi had more money he would buy a car'

Capitalizing on this second asymmetry between Spanish and Catalan I would like to sharpen (6):

(18) **I(H)M - ϕ CORRELATION (final version)**

I(h)M is parasitic on verb movement, which is parasitic on ϕ -richness

How can we square (18) with the empirical evidence so far reviewed? What I would like to suggest is that the more tense inflection a language has, the more fronting it can display.¹¹ This makes sense in the case of Catalan if one notices that, contrary to Spanish, simple past tense is lost: the forms in (19a) are replaced in present day Catalan by the periphrastic forms in (19b), formed by the present tense form of the

¹¹ See Zubizarreta (2007) for related ideas.

verb *anar* (Eng. *go*) plus the relevant infinitive. The indicative paradigm of Catalan thus lacks the richness Spanish exploits –this, I claim, is what makes the difference.

(19a) <i>Synthetic simple past tense</i>	(19b) <i>Periphrastic simple past tense</i>
<i>Jo cantí</i> I sing-PAST-1.SG	<i>Jo vaig cantar</i> I AUX-1.SG sing-INF
<i>Tu cantares</i> You sing-PAST-2.SG	<i>Tu vas cantar</i> You AUX-2.SG sing-INF
<i>Ell/Ella cantà</i> He/She sing-PAST-3.SG	<i>Ell/Ella va cantar</i> He/She AUX-3.SG sing-INF
<i>Nosaltres cantàrem</i> We sing-PAST-1.PL	<i>Nosaltres vam cantar</i> We AUX-1.PL sing-INF
<i>Vosaltres cantàreu</i> You sing-PAST-2.PL	<i>Vosaltres vau cantar</i> You AUX-2.PL sing-INF
<i>Ells/Elles cantaren</i> They-MASC/FEM sing-PAST-3.PL	<i>Ells/Elles van cantar</i> They-MASC/FEM AUX-3.PL sing-INF

With this in mind, let us go back to the asymmetries between finite and non-finite clauses with respect to left-peripheral fronting. Consider the data again:

(20) *Finite clauses: ‘active’ peripheral fronting*

- a. Luis dice que, los libros_i, ya los_i leyó. (Spanish)
 Luis say-3.SG that, the books, already CL-them read-3.SG
 ‘Luis says that the books he already read’
- b. Luis dice que CERVEZA ha bebido (y no sidra). (Spanish)
 Luis say-3.SG that BEER have-3.SG drunk (and not cider)
 ‘Luis says that BEER he has drunk (and not cider)’
- c. Vi a Luis leyendo los libros. (Spanish)
 see-PAST-1.SG to Luis reading the books
 ‘I saw Luis reading the books’

(21) *Non-finite clauses: ‘weak’ peripheral fronting*

- a. ??Luis quiere, los libros_i, leerlos_i. (Spanish)
 Luis want-3.SG, the books, read-INF-CL-them
 ‘Luis wants the books to read them’

- b. *Luis quiere CERVEZA beber (y no sidra). (Spanish)
 Luis want-3.SG BEER drink-INF (and not cider)
 ‘Luis wants BEER to drink (and not cider)’
- c. *Vi a Luis, los libros, leyéndolos. (Spanish)
 see-PAST-1.SG to Luis, the books, reading-them
 ‘I saw Luis the books reading them’

I want to extend the same logic to these paradigms: since infinitivals lack rich overt inflection,¹² I expect the verb to show weak head movement (in particular, I assume verbs never reach C in non-finite contexts). As a consequence, we just need to entertain that there is a connection between rich (tense) inflection, verb movement, and left-peripheral fronting –under that scenario, postulation of a truncation process, in the sense of Rizzi (1994), is not required.

But let us push things further. Consider (22), where, as the reader may see, infinitives do not license preverbal subjects (see Hernanz 1993; 1994; 1999, Ortega-Santos 2002, Rigau 1993; 1995, and Torrego 1998b, among others):^{13 14}

¹² This requires minor qualification. Infinitives are plausibly inflected for mood –they are, as Solà (1996) argues, non-finite subjunctives. This fits with observations relating infinitives and subjunctives (see Bosque 1990, Hernanz 1999, Kempchinsky 1987, Laka 1990, Landau 2004, Picallo 1984; 1985, San Martín 2004, Torrego & Uriagereka 1992, and Uribe-Etxebarria 1994, among others). A deeper study of the similarities between infinitives and subjunctives goes beyond the goals of this thesis. I refer the reader to recent work by Norbert Hornstein (cf. Hornstein 2007) to see a detailed account of subjunctives as inflected infinitivals.

¹³ Under some circumstances, subjects can appear preverbally, even with infinitives. This pattern is quite frequent in present day Spanish:

- (i) Para Juan decir eso, tienen que haberle hecho algo muy grave. (Spanish)
 for Juan say-INF that, have-3.PL that have-INF-CL-to-him done something very imp.
 ‘If Juan has said that, they must have done something very important to him’

A second pattern which features preverbal subjects in non-inflected clauses is what Etxepare & Grohmann (2005) call ‘adult root-infinitives:’

- (ii) Juan leer un libro?! Venga hombre! (Spanish)
 Juan read-INF a book Come-on man
 ‘Juan read a book, come on man!’
- (iii) Juan dice que él fregar los platos que ni por el forro. (Spanish)
 Juan say-3.SG that he wash-INF the dishes that nor by the cover
 ‘Juan says that he wash the dishes no way’

¹⁴ This observation is related to the fact that Spanish does not allow preverbal subjects in raising structures, such as *Juan* in (i). Note that there is no obvious reason for things to be this way. See section 4 for similar data.

- (i) *Parece [TP Juan T_{def} cantar] (Spanish)
 seems-3.SG Juan sing-INF
 ‘It seems that Juan sings’

(22)

a. [_{CP} C AI [_{TP} decir (María) eso (María)]], aluciné. (Spanish)

to-the say-INF (María) that (María), freak-out-PAST-1.SG

‘When María said that, I freaked out’

b. * [_{CP} C AI [_{TP} María decir eso]], aluciné. (Spanish)

to-the María say-INF that, freak-out-PAST-1.SG

‘When María said that, I freaked out’

In the system I am putting forward, the facts in (22) go hand in hand with the pair in (23). In plain terms, I want to relate the capacity for v^*/T_S to attract XPs to clitic placement patterns: just like infinitives of present day Spanish cannot attract clitics, they cannot attract material to their *Left Periphery*. As far as I know, this connection has gone unnoticed in the literature.

(23)

a. Beber lo. (cf. Beber Juan) (Spanish)

drink-INF-CL-it

‘To drink it’

b. *Lo beber. (cf. *Juan beber)¹⁵ (Spanish)

CL-it drink-INF

‘To drink it’

In sum, I claim that infinitives do not directly move to C, due to their poor morphological endowment. Although details remain to be filled in, I believe this claim to be essentially correct: there is in fact independent evidence that infinitives remain in T_S .¹⁶ The data in (24) indicate that C’s T can be deleted by a prepositional complementizer.

¹⁵ There is only one exception to this generalized enclisis pattern, to my knowledge: the case of Portuguese infinitival clauses with negation. See Raposo & Uriagereka (2005).

¹⁶ See Vicente (2007) for evidence that fronted infinitives are not in T, remaining in a lower position of the clause –according to Vicente (2007), v^* . The patterns I am considering here substantially differ from his, so my discussion is not incompatible with Vicente’s (2007) data.

(24)

- a. [_{CP} C*(Después de) [_{TP} hablar el presidente]], todos aplaudieron. (Spanish)
 after of speak-INF the president all applause
 ‘After the president talked, everybody gave him an applause’
- b. [_{CP} C*(Al) [_{TP} salir el sol]], se pusieron en camino. (Spanish)
 to-the come-out-INF the sun CL put-3.PL in path
 ‘When the sun came out, they were on their way’
- c. [_{CP} C*(Con) [_{TP} ser Juan rico]], vive miserablemente. (Spanish)
 with be-INF Juan rich live-3.SG miserably
 ‘Although Juan is rich, he lives miserably’
- d. [_{CP} C*(De) [_{TP} seguir así las cosas]], nos arruinaremos. (Spanish)
 of keep-INF this-way the things CL get-ruined-1.PL
 ‘If things remain the same, we will get ruined’

[from Hernanz 1994: 370-371]

In other cases, the logic forces us to assume that C’s T is valued by (long-distance) Agree. This should be the case of control infinitives, since we see not T material showing up in C:

- (25) Maia quiere [_{CP} C [_{TP} PRO hablar con Susana]] (Spanish)
 Maia want-3.SG talk-INF with Susana
 ‘Maia wants to talk to Susana’

Happily, Italian provides the kind of evidence we need, since T-to-C movement has a prepositional reflex.¹⁷

¹⁷ Catalan has similar control patterns, with a preposition in C:

- (i) Vam decidir [_{CP} C d’ anar-hi] (Catalan)
 AUX-1.PL decide-INF of go-INF-CL-there
 ‘We decided to go (there)’
- (ii) Hem pensat [_{CP} C de fer això] (Catalan)
 Have-1.PL thought of do-INF this
 ‘We thought we could do this’

Spanish also has the possibility to display (partial-) control dependents with a preposition. An example of this is (iii), where the periphrasis *decir de* (Eng. *say of*) means *proponer* (Eng. *propose*):

- (iii) María dijo [_{CP} C de ir al cine] (Spanish)
 María say-PAST-3.SG of go-INF to-the cinema
 ‘María proposed to go to the movies’

- (26) Io promisi [CP **C di** [TP PRO telefonare]] (Italian)
 I promise-PAST-3.SG of call-INF
 'I promised to call'

As expected, gerunds and past participles manifest T-to-C movement too. In this case the T element in C is typically covert:^{18 19}

- (27)
 a. [CP **C (*De)** [TP cantando la Caballé]], el teatro se llenará. (Spanish)
 of sing-GER the Caballé the theatre CL fill-FUT-3.SG
 'If Caballé sings, the theatre will be completely filled'
 b. [CP **C (*Por)** [TP efectuado el examen]], los alumnos respiraron. (Spanish)
 for made the exam the students breathe-3.PL
 'Once they finished the exam, students were happy'

[from Hernanz 1994: 371]

¹⁸ Another possibility is that verbs directly move to C, contrary to what I am arguing for here. Hernanz (1994) explores this possibility.

¹⁹ The fact that participles 'contain' a preposition has been defended by Masullo (2005), who points out that many of these verbal forms have been recycled as prepositions in both Spanish and English:

- (i) *past, except(ing), during, considering, etc.*
 (ii) *salvo (Eng. save), excepto (Eng. except), incluso (Eng. including), dado (Eng. given), etc.*

Gerunds have run an analogous fate, having been analyzed as forms containing a preposition.

It is interesting that gerunds, participials, and infinitives (when preceded by an overt preposition) can be used as predicates in copular sentences (see Masullo 2005, Mateu 2002, and references therein):

- (i) La biblioteca está [CP **C** [TP pasando el despacho de María]] (Spanish)
 the library be-3.SG pass-GER the office of María
 'The library is on passing María's office' (The library is right after María's office)
 (ii) La biblioteca está [CP **C** [TP pasado el despacho de María]] (Spanish)
 the library be-3.SG pass-P.PART the office of María
 'The library is once passed María's office' (The library is right after María's office)
 (iii) La biblioteca está [CP **C al** [TP pasar el despacho de María]] (Spanish)
 the library be-3.SG to-the pass-INF the office of María
 'The library is on passing María's office' (The library is right after María's office)

A similar contrast was found by Gallego (2004c) in the examples (iv) and (v), which are interpretively identical:

- (iv) Acabaron [CP **C** [TP queriéndole]] (Spanish)
 finish-PAST-3.PL love-GER-CL-him
 'They ended up loving him'
 (v) Acabaron [CP **C por** [TP quererle]] (Spanish)
 finish-PAST-3.PL for love-INF-CL-him
 'They ended up loving him'

The data in (i) through (v) just reinforce the hypothesis that non-finite clauses involve T-to-C movement.

The data in (27) could be related to the fact that gerund and participial clauses can never be direct verb dependents, something which falls into place if they are headed by a preposition:²⁰

- (28) *María quiere* [CP C [TP {cantar/*cantando/*cantado}]] (Spanish)
María want-3.SG sing-{INF / GER / P.PART}
 ‘*María wants to {sing/singing/sung}*’

Put yet in more general terms: I am connecting (28) to (29) (see chapter 2).

- (29) John reads (*of) the books.

What remains to be understood is why only infinitives can be verb dependents. One might invoke traditional observations and take the ‘nominal’ nature of infinitives to be the key, but this does not say how to translate that idea into formal terms.

Tentatively, I want to relate the facts in (28) to the categorical status of the embedded clause. In particular, I claim that infinitival clauses are T_S/CPs (assuming T-to-C movement yields a hybrid label), whereas gerund and past participle clauses are PPs (assuming either *Reprojection* or external Merge of P).

- (30)
- a. [_v*P v* ... [VP V ... [T/CP T/C ... [TP ...]]] *Infinitive dependent*
- b. * [_v*P v* ... [VP V ... [PP P ... [TP ...]]] *Gerund/Participle dependent*

Finally, notice that gerunds and participles also have a weak (almost null) peripheral fronting. Under normal circumstances, these non-finite forms disallow preverbal subjects as well as fronted constituents.

²⁰ Basically, this could account for why gerund and participial clauses typically manifest themselves as adjunct clauses.

(31)

a. [_{CP} C [_{TP} (*Redondo) jugando Redondo]], el Madrid no perdía. (Spanish)

Redondo play-GER Redondo, the Madrid not lose-PAST-3.SG

‘When Redondo played, Real Madrid did not lose’

b. * [_{CP} C [_{TP} Los libros, leyéndolos]], te serían más útiles. (Spanish)

the books, read-GER-CL-them, CL-to-you be-COND-3.PL more useful

‘The books reading them, they would be more useful (that way)’

(32)

a. [_{CP} C [_{TP} (*Redondo) fichado Redondo]], el Madrid mejoró. (Spanish)

Redondo signed-up Redondo, the Madrid improve-PAST-3.PL

‘When they signed up Redondo, Real Madrid improved’

b. * [_{CP} C [_{TP} REDONDO (no PROSINECKI) fichado]], el Madrid mejoró. (Spanish)

REDONDO not PROSINECKI signed-up, the Madrid improve-PAST-3.SG

‘REDONDO (and not PROSINECKI) signed up, Real Madrid improved’

This section has deepened into the properties of T_S in NSLs, starting by the macro-parameter differentiating English and NSLs (which, under my assumptions, is parasitic on v^* -to-T movement), and finishing by a macro-parameter related to morphological richness and Juan Uriagereka’s FP.

In the light of *Phase Sliding*, I have argued for a system where Uriagereka’s (1995a; 1995b) F can be dispensed with. Instead, we only have a ‘phasal’ version of T_S : v^*/T_S . Empirical evidence, though, suggests that F is not cross-linguistically homogeneous, there being important variation going from languages whose F is very active (E.Portuguese, Galician, and Spanish) to languages whose F is basically inert (French). In the middle, there are languages which manifest a soft F: Catalan and (some varieties of) Italian.

Building on traditional ideas from the GB literature I have taken rich (overt) inflection to be the key: if a verbal paradigm has rich tense inflection, it can boost verb movement, and, as a side-effect, left-peripheral fronting too.

I have concentrated on data that show non-trivial micro-parametric variation in the *Left Periphery* of Catalan and Spanish, a phenomenon I have attributed to verb movement: if verbs can move higher in Spanish than they do in Catalan, then they can display more left-peripheral activity. The ensuing logic looks like (33), a refined version of the “I(h)M - φ Correlation:”

(33) **THE F (MICRO-)PARAMETER**

Overt tense morphology is rich

If marked positive, languages can stick to (33) to move their verb up to the C domain rather freely, with the additional advantage of having a richer left-peripheral fronting. Note that the idea that tense morphology is the relevant factor in strengthening verb movement is coherent with the hypothesis (put forward in chapter 2) that v^* -to-T and T-to-C are parasitic on C, T_S, and v^* sharing a tense feature.

I have also compared the ‘mild’ *Left Periphery* of Catalan to that of non-inflected clauses. As is well-known, infinitival, gerund, and past participial clauses have important syntactic constraints: they preclude preverbal subjects and lack generalized peripheral fronting. Again, it seems to me natural to relate (33) to these observations.

Regardless of their defective status, I have claimed that non-finite clauses also manifest T-to-C movement. I have provided some empirical data in favor of this possibility, without developing a full investigation –the facts are, I think, promising enough, but some issues remain obscure: for one thing, we must still understand the ‘prepositional’ nature of gerund and participial clauses (see Hernanz 1993; 1994; 1999, Masullo 2005, Mateu 2002, and Rigau 1993; 1995), secondly, we must provide a more fine-grained account of why certain aspectual (i.e., T-like) elements have an interpretive effect on this adjunct clauses: as Etxepare & Grohmann (2005) note, building on original findings by Rigau (1993; 1995), adjunct infinitival clauses have temporal and causal readings:

- (34) [_{CP} C Al [_{TP} venir Pedro]], todos empezaron a murmurar. (Spanish)
 to-the come-INF Pedro, all start-PAST-3.PL to mutter-INF
 ‘When Pedro came in, everybody started to mutter’
 [from Etxepare & Grohmann 2005: 12]

Importantly, Rigau (1993; 1995) also observed that auxiliaries, negation, and durative modifiers block the temporal interpretation. Consequently, in (35), (36), and (37) only the causal interpretation is available:²¹

- (35) [_{CP} C A [_{TP} l’haver-me lliurat el premi]], el president em . . .
 to the-have-INF-CL-to-me given the award the president CL-to-me
 . . . va haver de donar la mà. (Catalan)
 AUX-3.SG have-INF of give-INF the hand
 ‘Since had given me the award, the president was forced to shake my hand’
 [from Rigau 1993: 232]

- (36) [_{CP} C Al [_{TP} no conduir borratxo]], la policia el va deixar marxar. (Catalan)
 to-the not drive-INF drunk the policeman CL-him AUX-3.SG let-INF go-INF
 ‘Since he did not drive drunk, the police officer let him go’
 [from Rigau 1993: 245]

- (37) [_{CP} C En [_{TP} estudiar a París durant dos anys]], en Pere va aprendre el francès.
 in study-INF to Paris during two years the Pere AUX-3.SG learn the French
 ‘Since he studied in Paris for two years, Pere learnt French’
 [from Rigau 1993: 233]

Let me just highlight one last finding of Rigau’s (1993), one that directly bears on the special nature of T_S in NSLs: adjunct infinitival T_S (in her analysis, Agr_S) can license

²¹ Modals also yield this causal interpretation, as Etxepare & Grohmann (2005) point out:

- (i) Al poner venir Pedro, todos empezaron a murmurar. (Spanish)
 to-the can-INF come-INF Pedro all start-PAST-3.PL to mutter-INF
 ‘Since Pedro could come, all started to mutter’
 (ii) Al soler llegar él siempre tarde, nadie se preocupó de su falta. (Spanish)
 to-the use-to-INF arrive-INF he always late none CL worry-3.PL of his absence
 ‘Since he used to be always late, none worried about his absence’
 [from Etxepare & Grohmann 2005: 13]

pro, assigning nominative Case. This, simply put, does not fit with standard observations about infinitives, which license PRO (by means of so-called “null Case;” see Chomsky & Lasnik 1995, Hornstein 2001; 2003, and Uriagereka 2006; forthcoming) in control structures, but not nominative.

Rigau (1993) convincingly argues that this is due to INFL having rich abstract agreement properties in Romance (in particular, she claims that INFL of adjunct infinitival clauses is [-Tense, +Agr]). Torrego (1998b) provides a similar analysis, claiming the [person] feature of T_S in adjunct infinitival clauses attracts a null subject clitic which makes it ‘stronger,’ enabling it to assign nominative:

$$(38) [_{CP} C [_{TP} T_S [_{v^*P} [_{DP} \textit{double} [_{D'} D \textit{pro}]]] v^* [_{VP} V \textit{IA}]]]]$$

The process of (38) is only available, according to Torrego (1998b), in NSLs which have clitic doubling –that would explain the different behavior of Italian.²²

Whatever the specifics of the analysis, the point is that both Rigau (1993) and Torrego (1998b) relate assignment of nominative to a rich T_S in NSLs, which can be a consequence of clitic doubling, *Phase Sliding*, or the conjunction of both.

Technology differs from author to author, but the intuition is the same: T_S displays a special cluster of properties, as we have seen. From my own perspective, all the phenomena we have considered in this section underscore the particular status of T_S in NSLs due to morphological richness.

²² Torrego (1998b) observes that although Italian also licenses nominative subjects in some infinitival clauses it does not allow argumental *pro*:

- (i) Senza aver piovuto, l'erba non può crescere. (Italian)
without have-INF rained the-grass not can-PAST-3.SG grow-INF
'Without having rained, grass could not grow'
- (ii) *Senza aver telefonato, loro sonno arrivati in ritardo. (Italian)
without have-INF called they be-3.PL arrived in delay
'Without having telephoned, they have arrived late'

[adapted from Torrego 1998b: 214]

See Torrego (1998b: 210-214) for an analysis of (i) and (ii).

If properly qualified, NSLs' morphological richness may also be responsible for the different status of Wh-Islands:

(39)

- a. ?/??_{[CP Which problem_i C do you wonder [CP how_z C PRO to solve t_i t_z]]?}
- b. *_{[CP How_z C do you wonder [CP which problem_i C PRO to solve t_i t_z]]?}

[from Lasnik & Saito 1992: 12]

According to Lasnik & Saito (1992), NSLs differ from English in assigning a perfect status to (39a) –for unknown reasons, they note. This is not the place to spell-out the details of an account of the asymmetry in (39) –or the fact that Italian and Spanish deal with argument extraction over adjuncts much better than English does. What interests me here is that one way to go about this asymmetry is to blame morphological richness: this could be the trigger to make multiple SPECs available.

Such a possibility is reinforced by the data in (40), taken from Uriagereka (2005b). As the reader may see, (40) confirms that multiple SPECs are marginally possible in Spanish, at least in the case of arguments:

(40)

- a. (?)No sé <sub>[CP quién_i a quién_z C ha enviado_k [TP t_i t_k una carta t_z]] (Spanish)
 not know-1.SG who to whom have-3.SG sent a letter
 'I do not know who has sent a letter to whom'</sub>
- b. *No sé <sub>[CP por qué_i cómo_z C han derrotado_k [TP pro t_k al Barcelona t_i t_z]] (Spanish)
 not know-1.SG for what how have-3.PL defeated to-the Barcelona
 'I do not know why Barcelona has been defeated how'</sub>

[from Uriagereka 2005b: 2]

In the next section two additional arguments in defense of the special status of T_S in NSLs are considered. I will start by discussing whether T_{def} exists in NSLs (I will claim it does, *contra* Ausín 2001), and I will end up proposing that subjunctive mood is an instance of T_{def}.

3. On T_{def} and Subjunctive in Spanish

Following the path laid down so far, my plan for the remainder of this chapter is as follows: I aim at gathering more evidence that T_S displays special properties in NSLs. In order to do so, I argue that Catalan and Spanish have a particular variety of T_{def} , a claim that is particularly intriguing under *Phase Theory*.

The intuition I want to pursue, following suggestions by Esther Torrego (p.c.), is that subjunctive dependents are defective structures, in the sense of Chomsky (2000; 2001).

It is an old observation that subjunctives manifest syntactic properties that make them differ from indicatives: long-distance obviation, tense restrictions, peripheral fronting, extraction, NPI licensing, quantifier rising, etc. (see Bosque 1990, Hornstein & San Martín in press, Kempchinsky 1987, Laka 1990, Picallo 1985, San Martín 2004, Torrego & Uriagereka 1992, Uribe-Etxebarria 1994, among others).

At the relevant level of abstraction, a subjunctive dependent clause such as (41) seems to be the counterpart of the ECM in (42): interpretively, they are equivalent.

(41) Quiero [CP C que María venga] (Spanish)
 want-1.SG that María come-SUBJ-3.SG
 ‘I want that María come’

(42) I want for María to come.

As noted by Kempchinsky (1987), subjunctives manifest a process of “domain extension,” similar to the one I noted when exploring Uriagereka’s (1999b) analysis of obligatory inversion. This can be seen in (43), where Condition (B) ignores the clause boundary signaled by the complementizer *que* (Eng. *that*):²³

²³ There are some counterexamples to this long-distance obviation effect –not to mention that some languages lack it (e.g., Greek; see Picallo 1985, San Martín 2004; 2007, and Uriagereka 1988a). Itziar San Martín (p.c.) informs me that there are two contexts where obviation fails: passives and structures with a modal. The judgments in (i) and (ii) are hers.

(i) Doctor_i, quiero que pro_i ya no pueda fumar más. (Spanish)

- (43) Al Capone_i quiere [CP C que {*pro_i/*él_i} mate a Ness] (Spanish)
 Al Capone want-3.SG that he he kill-SUBJ-3.SG to Ness
 ‘Al Capone wants for him to kill Ness’

The obviation effect in (43) is similar to that in (44), where raising-to-object occurs (see Lasnik 1999a; 2002; 2003a and Lasnik & Saito 1999):

- (44) Jack_i believed {*him_i/himself_i} [TP t_i T_S to be immoral]
 [from Lasnik & Saito 1999: 9]

The sentence in (44) shows that pronouns and anaphors are in complementary distribution in English after object raising. Things are different in Spanish, as raising is impossible in subjunctive dependents.

However, as can be seen in (45), anaphors are disallowed in the subject position of subjunctive dependents in Spanish (plausibly, because of they are ϕ -defective, see Burzio 1986; 1991).

- (45) *Al Capone quiere [CP C que [TP sí (mismo) T_S mate a Ness]] (Spanish)
 Al Capone want-3.SG that SELF (same) kill-SUBJ-3.SG to Ness
 ‘Al Capone wants himself to kill Ness’

In a nutshell, it is as if Spanish subjunctives were ECMs, except for the fact that there is a clear clause CP boundary, signaled by *que*. English can also display a

-
- doctor, want that pro already not can-SUBJ-1.SG smoke-INF more
 ‘Doctor, I want to be able to smoke no more’
- (ii) María_i quiere que pro_i sea arrestada. (Spanish)
 María want-3.SG that be-SUBJ-3.SG arrested
 ‘María wants for her to be arrested’
- I disagree with San Martín’s judgments: to my ear, obviation only fails in (i). A more precise contrast is that between (iii) and (iv):
- (iii) pro_i Espero que pro_i lo pueda hacer. (Spanish)
 pro hope-1.SG that pro CL-it can-SUBJ-1.SG do-INF
 ‘I hope I can do it’
- (iv) *pro_i Espero que pro_i lo haga. (Spanish)
 pro hope-1.SG that pro CL-it do-SUBJ-3.SG
 ‘I hope I do it’

prepositional complementizer (namely, *for*): but if it shows up, raising becomes unavailable, and all its side-effects (e.g., binding, NPI licensing, etc.) disappear:

- (46) *_{[CP C [TP I wanted very much [CP C *for* [TP those men_i to be fired]] . . .}
 . . . because of each other_i's statements]]

[from Lasnik & Saito 1999: 20]

The same holds if the clause boundary is signaled by *that*:

- (47) *_{[CP C [TP The DA proved [CP C *that* [TP the defendants_i were guilty]] . . .}
 . . . during each other_i's trials]]

[from Lasnik & Saito 1999: 12]

The example in (48) shows that, when raising-to-object does occur, the aforementioned effects reappear:²⁴

- (48) ?_{[CP C [TP The DA proved the defendants_i [TP t_i to be guilty] . . .}
 . . . during each other_i's trials]]

[from Lasnik & Saito 1999: 11]

A problematic issue for any analysis of obviation comes from binding theory itself: minimalism has no general binding account. The most detailed one is still (49), taken from Chomsky (1993a):²⁵

(49) **BINDING CONDITIONS**

- a. If α is an anaphor, interpret it as coreferential with a c-commanding phrase in D.²⁶
- b. If α is a pronominal, interpret it as disjoint from every c-commanding phrase in D.
- c. If α is an R-expression, interpret it as disjoint from every c-commanding phrase.

[from Chomsky 1993a: 43]

²⁴ Chapter 4 discusses the consequences of raising-to-object in detail.

²⁵ The exception is Reuland (2001; 2006a; 2006b). See Hornstein (2001) and Boeckx et al. (2004) for a movement approach to binding.

²⁶ "D" stands for relevant local domain (see Chomsky 1993a: 43) –presumably a strong phase, in current terms. See Lasnik & Uriagereka (2005: chapter 7) for discussion.

Given this, we need two things: first, some binding guidelines, and, two, a plausible way to extend them to (long-distance) obviation. In section 3.5. I sketch a Probe-Goal approach to binding, building on Uriagereka & Gallego (in progress), in section 3.5., but first I need to discuss the status of T_{def} in Spanish.

3.1. T_{def} in Spanish

As seen in chapter 2, an important property concerning phase heads is that they come in two varieties: complete and defective. In chapters 1 and 2 we defined defectiveness as follows:

(50) **DEFECTIVENESS**

An LI is defective if it lacks some feature(s) of a given class

It was also pointed out what categories can be defective within Chomsky's *Phase Theory*:

(51) **DEFECTIVE CFC**

- a. T_{def} : raising and ECM structures
- b. $v^*_{\text{def}}(v)$: unaccusative structures

As noted, it is odd for defectiveness to affect T_S and not C in Chomsky's (2007; to appear) phase-head-driven version of *Phase Theory* –and, even more so that T_S is even projected in those cases: T_S should not be projected if C is not.

To get around this drawback, I modify (51) as below:

(52) **PHASE HEADS**

Phase Head	Variety
C	C^* (C-T assigns nominative Case)
	C_{def} (C-T fails to assign nominative Case)
v	v^* (v^* -V assigns accusative Case)
	v_{def} (v -V fails to assign accusative Case)

The box in (52) incorporates a defective version of C, which this tries to capture the intuition that subordination is always mediated by this category, even in a defective fashion (an idea that was suggested to me by both Jordi Fortuny and Esther Torrego through personal communication). With this in mind, let us study the C-T_{def} dependency in more detail. Consider, to begin with, the two standard cases of T_{def}: raising and ECM.

(53)

- a. John_i seems to Mary [C_{def} t_i to T_{def} [t_i v* like Susan]] Raising
 b. Mary_i believes [John V [C_{def} t_i to T_{def} [t_i v* like Susan]]] Exceptional Case Marking

These data show the correlation between absence of a φ-complete C, absence of φ-complete T_S, and the fact that the subjects *John* and *Mary* cannot be assigned nominative: they remain active, their Case depending on a higher Probe. What this higher Probe turns out to be is the relevant factor: in raising it is T_S, in ECM it is v*.²⁷

As argued by Torrego (1998a), it seems that languages of the Spanish sort lack *bona fide* ECM constructions (see also Ausín 2001: 65-69). This is correct, as to my ear, the structures in (54) are fully out.

(54)

- a. *Juan considera [v*P a María_i v* [TP t_i ser [SC t_i inteligente]]] (Spanish)
 Juan consider-3.SG to María be-INF intelligent
 ‘Juan believes María to be intelligent’
 b. *Juan cree [v*P a María_i v* [TP t_i ser [SC t_i inteligente]]] (Spanish)
 Juan believe-3.SG to María be-INF intelligent
 ‘Juan believes María to be intelligent’
 c. **Juan quiere [v*P a María v* [TP t_i llamar a su hermano]]] (Spanish)
 Juan want-3.SG to María call-INF to her brother
 ‘Juan wants María to call her brother’

²⁷ I am presenting here Chomsky’s (2000; 2001; to appear) approach to defectiveness. As argued chapter 2, it can be recast under Pesetsky & Torrego’s (2001; 2004; 2007) system if T_S lacks a value for its T feature, or, more drastically, if there is no T_S head at all (the latter possibility would be problematic, for the preposition *to* is usually analyzed as T_S, but see Wurmbrand 2001; 2005).

The correct Spanish counterparts of the English translations are in (55), with an apparently subordinate clause, introduced by the complementizer *que* (Eng. *that*):

(55)

- a. Juan considera [CP que María es inteligente] (Spanish)
 Juan consider-3.SG that María be-3.SG intelligent
 ‘Juan considers that María is intelligent’
- b. Juan cree [CP que María es inteligente] (Spanish)
 Juan believe-3.SG that María be-3.SG intelligent
 ‘Juan believes that María is intelligent’
- c. Juan quiere [CP que María llame a su hermano] (Spanish)
 Juan want-3.SG that María call-SUBJ-3.SG to her brother
 ‘Juan wants that María call her brother’

The same facts hold in Catalan and French. However, following an observation by Kayne (1984), Torrego (1998a) points out that French *croire* (Eng. *believe*) allows a lexical subject when in *wh*-form. The relevant contrast is in (56):

(56)

- a. [CP Quel garçon_i crois-tu [TP t_i être [SC t_i le plus intelligent de tous]]? (French)
 what boy believe-2.SG-you be-INF the most intelligent of all
 ‘Which boy do you believe to be the most intelligent of all?’
- b. *Je crois [TP Jean_i être [SC t_i le plus intelligent de tous]] (French)
 I believe-1.SG Jean be-INF the more intelligent of all
 ‘I believe Jean to be the most intelligent of all’

[from Torrego 1998a: 52]

Torrego (1998a) argues that a similar effect is found in Spanish, noting that raising of marked accusative is worse. Again, I agree.

(57)

a. ?[_{CP} Qué problema C crees [_{TP} t_i ser [_{SC} t_i irresoluble]]]? (Spanish)

what problem believe-2.SG be-INF irresolvable

‘Which problem do you believe to be irresolvable?’

b. *[_{CP} A qué alumno C crees [_{TP} t_i ser [_{SC} t_i inteligente]]]? (Spanish)

to what student believe-2.SG be-INF intelligent

‘What student do you believe to be intelligent?’

[from Torrego 1998a: 52]

Here too, it seems to me that there is a contrast that depends on the embedded verb: only stative verbs allow for a perfect wh-extraction.

(58)

a. ?[_{CP} Qué niño_i C crees [_{TP} t_i ser [_{SC} t_i bastante simpático]]]? (Spanish)

what boy believe-2.SG be-INF quite nice

‘Which boy do you believe to be quite nice?’

b. *[_{CP} Qué niño_i C crees [_{TP} t_i leer tantos libros]]? (Spanish)

what boy believe-2.SG read-INF so-many books

‘Which boy do you believe to read so many books?’

For unknown reasons, (58b) sounds better if a series of auxiliaries/modals are sandwiched between the would-be ECM and the embedded verb.²⁸

²⁸ This effect, which is admittedly subtle, looks similar to what is found in the subjunctive/infinitive contrast. That is to say, the ameliorating effect of auxiliaries in (59) is also found in (i) and (ii):

(i) *Juan_i duda [_{CP} PRO_i ir al cine] (Spanish)

Juan doubt-3.SG go-INF to-the cinema

‘Juan doubts to go to the cinema’

(ii) Juan_i duda [_{CP} poder PRO_i ir al cine] (Spanish)

Juan doubt-3.SG can-INF go-INF to-the cinema

‘Juan doubts to be able to go to the cinema’

(iii) Juan_i duda [_{CP} PRO_i haber ido al cine] (Spanish)

Juan doubt-3.SG have-INF gone to-the cinema

‘Juan doubts to have gone to the cinema’

Notice, furthermore, that the modal *poder* and the auxiliary *haber* have an analogous effect to that created by the preposition *de* (Eng. *of*) and the conjunction *si* (Eng. *whether*).

(iv) Juan duda [_{CP} *de/si* C [_{TP} PRO ir al cine]] (Spanish)

Juan doubt-3.SG of/whether go-INF to-the cinema

‘Juan doubts whether to go to the cinema’

(59)

a. ??[_{CP} Qué niño_i C crees [_{TP} t_i haber [_{PrTP} t_i leído tantos libros]]]? (Spanish)

what boy believe-2.SG have-INF read-INF so-many books

‘Which boy do you believe to have read so many books?’

b. ?/??[_{CP} Qué niño_i C crees [_{TP} t_i haber [_{PrTP} t_i podido [t_i leer tantos libros]]]]? (Spanish)

what boy believe-2.SG have-INF could read-INF so-many books

‘Which boy do you believe to have been able to read so many books?’

Happily, as Juan Uriagereka makes me note, the same asymmetry with respect to auxiliaries is found in English too:

(60)

a. I believe John_i [_{TP} t_i to t_i read books]

b. *I believe John_i [_{TP} t_i to t_i have t_i read books]

This asymmetry between NSLs and English could reduce to a lexical property (NSLs lack ECM verbs of the *believe* type), but such a possibility is rather suspect, since no parallel behaviour is found in the *v**P phase. Having considered the basic facts about T_{def} (and the idea, to which I return, that Spanish has no ECM sentences), next section focuses on the raising variety.

3.2. Raising over Experiencer and Spanish *parecer*

This section is devoted to the nature of raising structures in Spanish, paying special attention to the parametric variation witnessed within Romance languages.

Contrary to what we have just see with respect to ECMs,²⁹ the literature on raising I am familiar with readily accepts that Spanish has a raising verb: *parecer* (Eng. *seem*).

²⁹ It might be worth investigating perception verbs take ECM dependents.

(i) Vi [a María cantar] (Spanish)
see-PAST-1.SG to María sing-INF
‘I saw María sing’

(ii) Quiero [a María estudiando ahora mismo] (Spanish)
want-3.SG to María studying now same
‘I want María studying right now’

Although embedded subjects in (i) and (ii) receive accusative Case, I am not convinced we have ECM structures. Such a possibility is reinforced by English data: as (iv) shows, perception

As argued by Torrego (2002), a remarkable trait of Spanish *parecer* concerns its behavior: apart from its raising use, it can work as a modal and as a control verb.³⁰

(61)

- | | | | | | |
|----|---|---------------------|--|----------------|-----------|
| a. | Me | parece | que Juan cocina. | <i>Raising</i> | (Spanish) |
| | CL-to-me | seem-3.SG | that Juan cook-3.SG | | |
| | 'It seems to me that Juan cooks' | | | | |
| b. | Parece | que Juan cocina. | <i>Modal</i> | (Spanish) | |
| | seem-3.SG | that Juan cook-3.SG | | | |
| | 'It seems that Juan cooks' | | | | |
| c. | Le | parece | haber resuelto todas las dificultades. | <i>Control</i> | (Spanish) |
| | CL-to-him | seem-3.SG | have-INF solved all the difficulties | | |
| | 'It seems to him to have solved all the difficulties' | | | | |

I am going to leave aside the control use of *parecer*, focusing on the modal vs. raising distinction. Why I do this is that, if *parecer* happens to be exclusively a modal, then this would fit with the lack of ECM verbs, and, consequently, with the hypothesis (held by Ausín 2001) that Spanish lacks T_{def} entirely. Although this scenario is plausible, I would claim that it is not correct: *parecer* can be used as a raising verb, while subjunctive dependents are the Romance counterpart of ECMs.

It is important to highlight that, under Torrego's (2002: 255-257) analysis, the status of *parecer* is parasitic on the presence of the experiencer: the experiencer forces the 'raising' analysis, providing the subject experiencer light verb with the relevant inflectional features to become v^* . Assuming the defective C head in (52), the two structures at stake are as follows:

dependents lack the infinitival morpheme *to*, indicating that there is no T_{sP} (see Rizzi 2000 for more discussion):

- | | | |
|-------|------------------------------------|------------------------|
| (iii) | I {expected/wanted} [John go home] | <i>ECM</i> |
| (iv) | I saw [John go home] | <i>Perception verb</i> |

[from Rizzi 2000: 189]

³⁰ According to the literature (see Ausín 2001: 62 and Torrego 2002: 257) the raising vs. modal use of *parecer* depends on one thing: the appearance of the experiencer.

(62)

- a. [_{v*P} EXP [Cl-*v**] *parecer* [_{CP} C_{def} [_{TP} T_{Sdef} [_{v*P} EA *v** [_{VP} V IA]]]]]] *parecer qua Raising*
 b. [_{v*P} *parecer* T_S [_{v*P} EA *v** [_{VP} V IA]]] *parecer qua Modal*

A different analysis is pursued by Ausín (2001), who provides interesting pieces of evidence in favor of analyzing *parecer* exclusively as a modal. The main argument of Ausín's (2001) concerns so-called *Experiencer Paradox* (see chapter 1), a locality constraint which follows from Chomsky's (1995b) MLC (see chapter 1 and section 5 below).

In the next section I review two recent analysis put forward to capture not only the *Experiencer Paradox*, but also the distinct behaviour between English and Romance.

3.2.1. Boeckx's (1999a; 2000a) and Torrego's (2002) Accounts

Consider the raising structure in (63) in order to see what the *Experiencer Paradox* follows from.

(63) [_{CP} C [_{TP} John_i T_S seems [to Mary [_{TP} t_i to be the best]]]]

Under standard assumptions, matrix T_S in (63) attracts *John* from the embedded subject position (a subject-to-subject raising case). Crucially, given the MLC, the experiencer DP *Mary* should block Agree (T, *John*). Strikingly, it does not: this is the paradox.

(64) John_i seems [to Mary] [t_i to be the best]

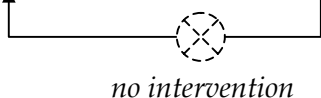

no intervention

Note, actually, that for there to be a true paradox, one must make sure that there is a c-command dependency not only between matrix T_S and *John*, but crucially between *Mary* and *John* as well. The examples in (65), taken from Boeckx (1999a), provide us

with the evidence we need: in (65a) *John* can bind within the raised subject *pictures of himself* prior to raising, while in (65b) *him* triggers a Condition (C) violation:³¹

(65)

- a. [_{CP} C [_{TP} [Pictures of himself_k]_i T_S seem to John_k [_{TP} t_i to be ugly]]]]
 b. [_{CP} C [_{TP} They_i T_S seem to him_k [_{TP} t_i to like John_{*k/j}]]]]

[from Boeckx 1999a: 228-231]

Yet the process is only paradoxical in English –in Spanish it is not, as the minimality effect in (66) shows:

- (66) * [_{CP} C [_{TP} Este taxista_i les_j parece *pro*_j [_{TP} t_i estar t_i cansado]]] (Spanish)

this taxi-driver CL-to-them seem-3.SG be-INF tired

‘This taxi driver seems to them to be tired’

In other words: it is Spanish that is well-behaved as far as the *Experiencer Paradox* is concerned. Ideally, one should expect the same picture to hold in other NSLs, but facts are much more complex.

It is worth pointing out that the *Experiencer Paradox* in and of itself is not parasitic on raising: as Torrego (1996b; 2002) argues, the experiencer blocks Agree even if the subject remains *in situ*, as shown in (67b):

(67)

- a. * [_{CP} C [_{TP} Este taxista_i T_S me parece [_{TP} t_i estar [_{SC} t_i cansado]]]] *raising* (Spanish)

this taxi-driver CL-to-me seem-3.SG be-INF tired

‘This taxi driver seems to me to be tired’

- b. * [_{CP} C [_{TP} T_S Me parece T_S [_{TP} estar [_{SC} cansado este taxista]]]] *no raising* (Spanish)

CL-to-me seem-3.SG be-INF tired this taxi-driver

‘This taxi driver seems to me to be tired’

³¹ I refer the reader to Ausín (2001: 51) for the relevant tests demonstrating that the experiencer c-commands into the embedded clause in Spanish.

That is to say, in (67b) the problem has nothing to do with raising, but rather with long-distance Agree (T, *este taxista*) –as expected, if feature checking reduces to Agree (see chapter 1).

Things complicate even further when other Romance languages are considered. First, as observed by Torrego (2002), French and Italian do not fit with Spanish: on the one hand, they behave like English when the experiencer clitic is present, as there is no intervention effect.³²

(68)

a. Gianni gli sembra essere stanco. (Italian)

Gianni CL-to-him seem-3.SG be-INF tired

‘Gianni seems to him to be tired’

b. Ce conducteur me semble être fatiguée. (French)

this driver CL-to-me seem-3.SG be-INF tired

‘This driver seems to me to be tired’

[from Torrego 2002: 253]

Whereas, on the other hand, lexical experiencers (the ‘doubles’) do intervene:

(69)

a. *Gianni sembra a Maria essere stanco. (Italian)

Gianni seem-3.SG to Maria be-INF tired

‘Gianni seems to Maria to be tired’

³² Catalan does not entirely pattern with Spanish: it does demand the clitic when the experiencer is overt, but raising constructions are in general marginal, for unknown reasons:

(i) *(Li) sembla a la Maria que en Joan no vindrà. (Catalan)

CL-to-her seem-3.SG to the Maria that the Joan not come-FUT-3.SG

‘It seems to Maria that Joan will not come’

Importantly, Catalan shows a strong minimality effect when the experiencer shows up. The contrast between (i) and (ii) is clear to speakers.

(ii) La Maria_i (*em) sembla [t_i tenir massa feina] (Catalan)

the Maria CL-to-me seem-3.SG have-INF too-much work

‘Maria seems to me to have too much work’

b. ??Maria semble à Jean être fatiguée. (French)

Maria seem-3.SG to Jean be-INF tired

‘Maria seems to Jean to be tired’

[from Torrego 2002: 253]

Bearing this background in mind, let us now discuss the analyses Boeckx (1999a) and Torrego (2002) propose in order to account for the *Experiencer Paradox*. Consider Boeckx’s (1999a; 2000a) first.

Building on previous analyses (notably, Epstein et al.’s 1998 and Kitahara’s 1997),³³ Boeckx (1999a) argues that the paradox (in the few languages where it arises, including English) vanishes if it is assumed that the preposition somehow ‘hides’ the experiencer so that this does not count as a potential intervener between the Probe launched by matrix T_S and its Goal, the embedded subject. Accordingly, prior to raising, the preposition ‘shields’ the experiencer, making its ϕ -features invisible.³⁴

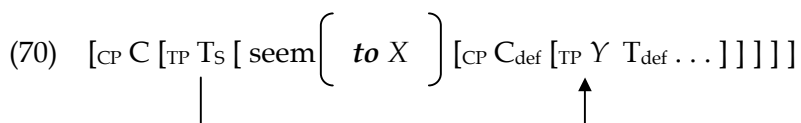

After raising takes place, the preposition *to* is reanalyzed with *seem*, much like – Boeckx 1999a suggests– *about* is reanalyzed with *talk* in (71):³⁵

³³ The defining trait of Epstein et al.’s (1998) and Kitahara’s (1997) treatments is a change of the experiencer’s phrase structure: prior to raising, it is a PP (this allows bypassing the MLC), but afterwards it becomes a DP –in the case of Kitahara (1997) the experiencer DP covertly raises to SPEC-P, whereas for Epstein et al.’s (1998) the preposition is eliminated.

³⁴ However, the preposition does not seem to totally hide the experiencer. As Boeckx (1999a; 2000a) notes, evidence indicates that, despite experiencers cannot be Goals for raising, they do establish an Agree dependency with matrix T_S after all (they do not agree properly speaking, but their [person] feature is matched). This can be seen in (i), where the experiencer *to Mary* blocks long-distance Agree with the distant associate *men*:

(i) There {*seem/seems} to Mary to be men in the room.

[from Boeckx 2000a: 371]

Boeckx (2000a) argues that these facts (and similar ones involving quirky subjects) can follow if datives and T_S can engage a minimal Agree dependency, restricted to [person]: assuming a projection encoding point-of-view (akin to Uriagereka’s 1995a; 1995b F), Boeckx (2000a) argues that such projection’s [person] feature matches that of datives.

³⁵ Boeckx (2000a: 374) refines his own previous analysis, arguing that reanalysis takes place overtly in languages like Spanish, but covertly in English. These matters will become relevant in chapter 4.

real experiencer in Spanish (a null *pro*) acts as a Probe, checking its Case against the clitic. If that is so, when P is merged, there is no active element left and valuation cannot take place, causing the derivation to crash.

Two aspects of Torrego's (2002) analysis strike me as problematic: one, the Probe status of *pro*, and, two, the fact that valuation cannot occur even though the clitic has checked its Case.

The first problem is more general, and concerns the possibility for pronouns to be Probes. Torrego (2002) follows Chomsky's (2004) analysis of expletive pronouns and adapts it to raising cases, but there is one crucial aspect that makes Chomsky's (2004) proposal plausible, unlike Torrego's: in Chomsky (2004), only expletives (English *there* and French *il*) can be Probes, which makes sense if their agreement features are unvalued.

In the case of the dative experiencer, the hypothesis that the real argument, *pro*, is an expletive of sorts is not obvious. A better way out to the Spanish facts, I believe, is Boeckx's (1999a; 2000a). Unfortunately, I believe the latter analysis also begs the question of why Spanish has P-to-V incorporation (i.e., reanalysis) in the overt component, contrary to English.

Having pointed out some problematic aspects of Boeckx's (1999a; 2000a) and Torrego's (2002) analyses of the *Experiencer Paradox*, I would like to propose an alternative way to approach the facts.

3.2.2. A New Analysis

The previous section made it clear that there are two scenarios to address with respect to raising structures in Romance: raising structures *with double* and raising structures *without double*. Consider the second scenario first.

The question that must be answered is why lexical experiencers in French and Italian block raising. According to the logic of Boeckx's (2000a) analysis, this would be due to reanalysis of the double's preposition taking place covertly. Torrego (2002),

however, suggests that the French and Italian preposition *a* (Eng. *to*) is a mere spell-out of Case, so that lexical experiencers are DPs at the relevant level.

As regards the first raising scenario, we must find an explanation for why clitic intervention arises in Spanish and Catalan, but not in Italian and French. Boeckx (2000a: 374-375) accounts for the lack of intervention by taking French and Italian experiencer clitics to be directly generated in a position high enough to eliminate the MLC configuration (in particular, they are generated as heads on T_S). Though plausible (see Sportiche 1998 and Zubizarreta 1999), Boeckx's (2000a) move raises doubts: assuming a "big-DP" analysis (see Uriagereka 1995b and references therein), why would clitics generate in different positions in languages which are very similar in most respects?

Torrego (2002) adduces a different cause for the paradox, defending a derivational process which changes the status of the clitic. In particular, Torrego (2002) proposes that the experiencer clitic is base-merged as an XP, but changes its phrase structure status to X after cliticization with T_S. Once in T_S, the experiencer does not c-command the embedded subject.

Regardless of whether Torrego's (2002) analysis is correct (I will suggest it is not), we should be worried about why only Spanish experiencer clitics trigger intervention effects.

In order to account for the facts here I will assume, following Boeckx (1999a; 2000a), that the preposition *to* in English acts as a 'syntactic shield' which repels the ϕ -Probe launched by matrix T_S. Note that the same explanation will not do for French and Italian, since in these languages the double intervenes, but here is where Torrego's (2002) ideas come into play: it may well be that the dative *a* of French and Italian is like the *a* (Eng. *to*) displayed by Case marked accusative objects in Spanish –a mere spell-out of Case.

The literature in fact is replete of proposals distinguishing between strong/real/lexical vs. weak/fake/functional prepositions (see Abels 2003, Demonte 1991, Pesetsky & Torrego 2004, Torrego 1998a, and references therein). Suppose we

(76)

a. *Juan le parece estar cansado. (Spanish)

Juan CL-to-him seem-3.SG be-INF tired

‘Juan seems to him to be tired’

b. *Aquest conductor em sembla estar cansat. (Catalan)

this driver CL-to-me seem-3.SG be-INF tired

‘This driver seems to me to be tired’

The question here is why the experiencer clitic intervenes in Catalan and Spanish but not in French and Italian. It is tempting to exploit Torrego’s (1996b; 2002) observation that only the latter languages can optionally drop the clitics.

I would like to rephrase this distinction and claim that *experiencer clitics*, being obligatory in Catalan and Spanish, license a null *pro* only in these languages, French and Italian resorting to a more impoverished structure. The idea is roughly as in (77):

(77)

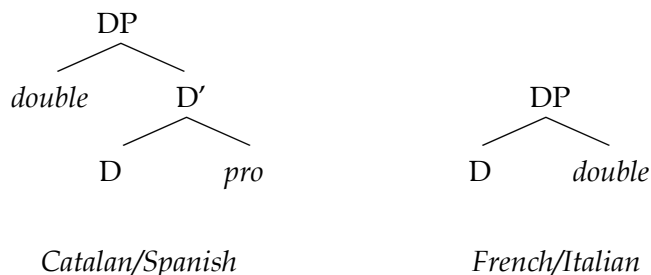

Assuming this asymmetry to be on the right track, there is a way to make sense of the data in (75) and (76). Consider the derivational point at which T_S wants to attract the embedded subject across the experiencer in Catalan/Spanish vis-à-vis French/Italian:

(78)

a. [CP C [TP *clitic*_i T_S [DP t_i *pro*] seem [CP C_{def} XP T_{def} . . .]]] Catalan/Spanish

b. [CP C [TP *clitic*_i T_S [DP t_i] seem [CP C_{def} XP T_{def} . . .]]] French/Italian

According to (78), only Catalan and Spanish experiencer doubling structures leave something behind after cliticization: the real experiencer, a null *pro*. This is, I claim, what causes the intervention in Catalan and Spanish:

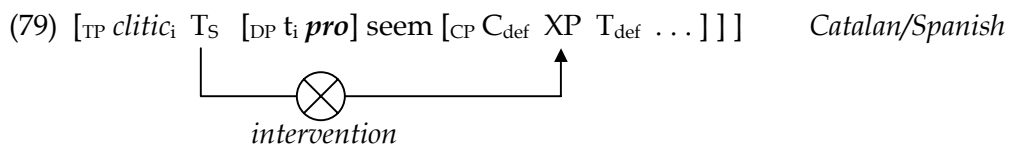

If this idea can be maintained, then we have a plausible explanation as for why raising structures with clitics differ cross-linguistically: they do because the clitic systems license a null *pro* only in Catalan and Spanish.

This analysis is reinforced by the special status of the definite articles in Spanish and Catalan, which, contrary to other Romance languages, appear to license a null *pro* in some contexts, like partial NP ellipsis (I thank Juan Uriagereka for this observation):^{38 39}

(80)

- a. La *pro* de María. (Spanish)
 the *pro* of María
 ‘The one of María’
- b. *La *pro* con patas. (Spanish)
 the *pro* with legs
 ‘The one with legs’

Also relevant is the fact, discussed in Bruccart (1992; 1999) and Donati (1995), that only Spanish and Catalan allow for so-called *semi free relatives* –those relatives where a definite article licenses a null category (be it *pro* or a silent relative operator):

³⁸ See Uriagereka (1988a: 2.2.3) for an account of this an additional facts in terms of agreement. In particular, Uriagereka (1988a) relates the status of “rich” Ds not only to the licensing of *pro*, but also to sub-extraction. Roughly put, the richer the D, the more of a barrier it constitutes, as is shown by the absence of *Left Branch Constraint* in languages without overt Ds (e.g., Latin, Czech, Serbo Croatian, etc.). For some problems with this thesis and possible solutions, see Boeckx (2003a: 38 and ff.).

³⁹ For analogous instances of *pro* licensing in Spanish, see Leonetti (1999). See Raposo (2002) for much interesting discussion about this phenomenon.

(81)

a. La silla sobre la que te sentaste. (Spanish)

the chair on the that CL-you sit-down-PAST-2.SG

'The chair you sat down on'

b. *La sedia su la che ti sei sedutto. (Italian)

the chair on the that CL-you AUX-2.SG sat-down

'The chair you sat down on'

c. *La chaise sur la que tu t'es asiss. (French)

the chair on the that you CL-you-AUX-2.SG sat-down

'The chair you sat down on'

[from Donati 1995: 590]

An advantage of this analysis is that it does not have to be adapted in order to account for the intervention effect created by the experiencer's double. In all Romance languages, this will violate Chomsky's (1995b) MLC, as (82) shows:

(82)

a. $[_{CP} C [_{TP} clitic_i T_S [_{DP} \textit{double} t_i \textit{pro}] \textit{seem} [_{CP} C_{def} XP T_{def} \dots]]]]$ Catalan/Spanish

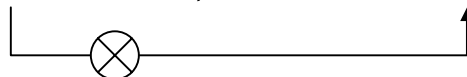

b. $[_{CP} C [_{TP} clitic_i T_S [_{DP} t_i \textit{double}] \textit{seem} [_{CP} C_{def} XP T_{def} \dots]]]]$ French/Italian

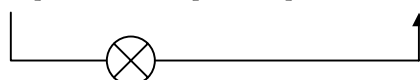

In these sections, I have reviewed some of the puzzles that concern the nature of raising verbs in NSLs and English. I have concentrated on what I take to be the most accurate analysis of *Experiencer Paradox*: Boeckx's (1999a; 2000a) and Torrego's (2002). I have shown my skepticism about some aspects of these accounts, providing an alternative analysis which tries to combine insights of both Cedric Boeckx and Esther Torrego: from the former I embrace the idea that prepositions like *to* can shield and be reanalyzed with their 'governing' verb, whereas from the latter I have taken the possibility for some clitics to license a little *pro*.

We need to go back to ECMs, but first I want to step back in order to consider Ausín's (2001) claim that Spanish *parecer* can never be used as a raising verb.

3.3. Ausín’s (2001) analysis: *parecer* as a modal

Ausín (2001) rejects the extended idea that *parecer* is a raising verb, analyzing it as a(n epistemic) modal. Let us consider the details.

The first argument against a raising analysis of *parecer* comes from the data in (83), originally reported by Torrego (1996b):⁴⁰

(83)

a. [_{CP} C [_{TP} Ese chico_i T_S me parece [_{SC} t_i inteligente]]] (Spanish)

that boy CL-to-me seem-3.SG intelligent

‘That boy seems intelligent to me’

b. * [_{CP} C [_{TP} María_i T_S me parece [_{SC} t_i descalza]]] (Spanish)

María CL-to-me seem3.SG barefoot

‘María seems barefoot to me’

[from Torrego 1996b: 110]

The important thing to note about (83a) is that there is an experiencer clitic (namely, *me*) and raising is still perfectly fine.

Analyses of the pair in (83) have changed through time: in Torrego (1996b) it was argued that there is no raising at all in these cases; more recently, accepting Ausín’s (2001) objections, Torrego (2002) adopts a movement account, suggesting: first, that P is not present in clauses containing individual level small clauses such as (83a), and, second, that the experiencer *pro* incorporates into the verb, becoming invisible to P.

Torrego’s (2002) analysis is not only cryptic (what triggers the presence and absence of P in the first place?), but also forces this author to assume that in sentences like (84), which are okay, there is no P projection either. In fact, Torrego (2002: 259) argues that, whenever P is absent, the *parecer-Experiencer* combination yields an ‘internal perception’ reading:

⁴⁰ It would be interesting to know whether the same facts hold in English. Unfortunately, the examples in (83) cannot be translated with *seem*, as English resorts to *look* (e.g., *Mary looks intelligent*).

(84) Le parece (a esta gente) que ese taxista . . .
 CL-to-them seem-3.SG (to these people) that that taxi-driver
 . . . está cansado. (Spanish)
 be-3.SG tired
 ‘It seems to these people that that taxi driver is tired’

Accordingly, (84) should be read as “these people *think* that the taxi driver is tired.”
 I agree.

Torrego (2002) adds that the existence of grammaticalized forms like *me parece* (Eng. *it seems to me*) or *Qué te parece?* (Eng. *what does it seem to you?*) meaning “I think” and “What do you think?” respectively reinforces her analysis. I agree again.

But there is one contradictory aspect here: if, according to Torrego (2002), P encodes point-of-view, why should P be absent when, on interpretive grounds, the combination *parecer-Experiencer* (e.g., *me parece*) means “I think” or “My opinion is that...”? All other things being equal, that type of evaluative interpretation should be compatible with (or even be a consequence of) Torrego’s (2002) P.

Ausín (2001) follows a different strategy to account for (83). Building on Raposo & Uriagereka (1995; 2002) and Fernández Leborans (1999), this scholar suggests that such contrast follows from the existence of two types of pseudo-copulative *parecer*:

(85)

2 types of <i>parecer</i>	Perception <i>paracer</i> -Compatible with stage/individual-level predicates
	Opinion <i>parecer</i> -Compatible only with individual-level predicates -Requires experiencer clitic

As evidence in favor of the dichotomy in (85), Fernández Leborans (1999) offers the data in (86) and (87):

(86) Perception “parecer”

a. Ana (*me) parece enferma. (Spanish)

Ana CL-to.me seem-3.SG sick

‘Ana seems to me to be sick’

b. María (*me) parece enfadada. (Spanish)

María CL-to.me seem-3.SG angry

‘María seems to me to be angry’

[from Fernández Leborans 1999: 2444]

(87) Opinion “parecer”

a. Ana me parece tímida. (Spanish)

Ana CL-to-me seem-3.SG shy

‘Ana seems to me to be shy’

b. Luis nos parece serio y trabajador. (Spanish)

Luis CL-to-us seem-3.SG dilligent and good-worker

‘Luis seems to us to be trust worthy and a good worker’

[from Fernández Leborans 1999: 2444]

When *parecer* is to be interpreted as “I think” or “I consider” (as ‘opinion’ *parecer*), the experiencer clitic must be present, and then stage level predicates (e.g., *angry*, *barefoot*, *sick*, etc.) are rejected. But, if so, note that *everything boils down to a matter of selection, not minimality*.

Differently put, the facts in (83b) and (86) do not have a raising *parecer*: in these cases we are dealing with an opinion *parecer*. In brief, (83b) and (86) are out for the same reason (88b) is:

(88)

a. Considero a María amable. (Spanish)

consider-1.SG to María nice

‘I consider María nice’

b. *Considero a María cansada. (Spanish)

consider-1.SG to María tired

‘I consider María tired’

As for (83a)'s grammatical status, it follows from the fact that *parecer* is not a raising verb there either: it is a pseudo-copulative verb meaning "look." Hence, *María parece inteligente* should be translated as *María looks intelligent*.

Once we have dismissed the first argument of Ausín's (2001), let us go back to more interesting data, those in (89):

(89)

a. [CP C [TP Juan T_S parece [TP t_i amar a María]]] (Spanish)

Juan seem-3.SG love-INF to María

'Juan seems to me to love María'

a. *[CP C [TP Juan_i T_S me parece [TP t_i amar a María]]] (Spanish)

Juan CL-to-me seem-3.SG love-INF to María

'Juan seems to me to love María'

Ausín (2001) addresses the key contrast in (89) by arguing that in both cases *parecer* is a modal,⁴¹ being analyzed exclusively as in (90b):

(90)

a. Juan parece [CP C_{def} [TP t_{Juan} amar T_{def} a María]] "parecer" qua Raising

b. Juan parece [TP t_{Juan} T_S amar a María] "parecer" qua Modal

In other words, and according to Ausín (2001): besides its use as main pseudo-copulative verb (i.e., 'perception' vs. 'opinion'), *parecer* can only be a modal, not a raising verb.⁴² Consequently, *parecer cannot appear with a clitic experiencer just because modals do not select experiencers*. Actually, Ausín (2001: 64) argues that the problem in (89b) goes beyond *parecer* being a modal, it follows from the fact that Spanish lacks T_{def} altogether.

⁴¹ See Ausín (2001: 62) for evidence that *parecer* without the experiencer behaves like a modal.

⁴² Obviously, the modal vs. raising distinction, as well as the issue of whether modals can be analyzed as lexical or as functional verbs, lies beyond the goals of this dissertation. For relevant discussion, I refer the reader to Cardinaletti & Shlonsky (2004), Cinque (1999; 2004), Ordóñez (2005), Picallo (1990), Solà (2002), Wurmbrand (2001; 2005; 2007), among others. For concreteness, the reader can assume that I take modals and auxiliaries to be in T_S, while raising verbs to be lexical heads (i.e., *v-V*).

I think this claim is too strong: Spanish does seem to lack ECMs of the English type (see next section for minor qualifications), but there is good reason to adopt Torrego’s (1996b; 2002) thesis that *parecer* is a raising verb. For one thing, *parecer*, contrary to modals, does not allow restructuring, as Torrego (1996b) first noted (Ausín 2001 remains silent about this):⁴³

- (91) ???[_{CP} C [_{TP} T_S Lo parecía [_{TP} *pro* haber acompañado t_i a casa]] (Spanish)
 CL-him seem-PAST-3.SG have-INF gone-with to home
 ‘She seemed to have taken him home’

[from Torrego 1996b: 104]

(92), another example of restructuring, is severely degraded when *parecer* is used.⁴⁴

(92)

- a. (*Lo) parece besar(lo). (Spanish)
 CL-him seem-3.SG kiss-INF-CL-him
 ‘She seems to kiss him’
- b. (Lo) puede besar(lo). (Spanish)
 CL-him may-3.SG kiss-INF-CL-him
 ‘She may kiss him’

In sum, it is rather dubious that *parecer* cannot be analyzed as a modal. Having concluded this, we are in a position to investigate the real status of ECMs in Spanish.

⁴³ Building on Fernández Leborans (1999), Ausín (2001) offers more evidence supporting the hypothesis that *parecer* is a modal, none of them totally conclusive, as far as I can see. Importantly, as I say, he does not assess the fact that *parecer* blocks restructuring. See Solà (2002) for additional evidence showing that *parecer* differs from restructuring verbs.

⁴⁴ As Juan Uriagereka observes, (92a) improves if an auxiliary is used (see section 3.1. above):

- (i) Lo parece haber besado. (Spanish)
 CL-him seem-3.SG have-INF kissed
 ‘She seems to have kissed him’

3.4. Subjunctive Dependents

This section assesses an issue that, despite appearances, is related to the controversial status of T_{def} in Spanish: subjunctive dependent clauses. If what I present here proves correct, these clauses will be shown to be another true instance of T_{def} (or, more precisely, $C-T_{\text{def}}$) in NSLs.

Given the importance of the long-distance obviation phenomenon in the context of subjunctives, I shall dedicate some space to sketch the account of binding put forward by Uriagereka & Gallego (in progress).⁴⁵

As is well-known, subjunctive dependent clauses show a number of asymmetries with respect of indicative ones. The most striking fact belongs to the realm of binding, where a poorly understood long-distance obviation arises between matrix and embedded subjects:

(93)

- a. *La Maria_i lamenta [_{CP} C que *pro*_i tingui tants problemes] (Catalan)
 the Maria regret-3.SG that pro have-SUBJ-3.SG so-many problems
 ‘Maria regrets that she have so many problems’
- b. La Maria_i diu [_{CP} C que *pro*_i té molts problemes] (Catalan)
 the Maria say-3.SG that pro have-3.SG many problems
 ‘Maria says that she has many problems’

Facts like these were taken by many scholars (particularly, Kempchinsky 1987) to argue that the binding domain of the embedded clause is ‘extended’ so that the embedded subject pronoun (*pro*, in the examples at hand) fell into the governing category of the matrix clause.

Technical details aside, we should worry not only about how to recast Kempchinsky’s (1987) insightful analysis in current terms, but also about having a

⁴⁵ In Uriagereka & Gallego (in progress), we adopt Chomsky’s (2000; 2001) theory of Case, not Pesetsky & Torrego’s (2001). For the sake of exposition, I will not modify this here.

general account of binding. As noted above, (94) is all we have (but see Reuland 2001; 2006a; 2006b):

(94)

- a. If α is an anaphor, interpret it as coreferential with a c-commanding phrase in D.
- b. If α is a pronominal, interpret it as disjoint from every c-commanding phrase in D.
- c. If α is an R-expression, interpret it as disjoint from every c-commanding phrase.

[from Chomsky 1993a: 43]

Chomsky (to appear: 8) mentions in passing how binding could be reformulated within a Probe-Goal system, eliminating the necessity for the binder to c-command the bindee: all that is needed for Condition (A) to be satisfied –Chomsky argues– is for T_S to Agree with binder and bindee in a multiple fashion, as sketched in (95):

(95) $[_{CP} C [_{TP} T_S [_{v^*P} EA \ v^* [_{VP} V \ IA \]]]]$ *Multiple Agree* (T_S , EA, IA)

In Uriagereka & Gallego (in progress) we pursue this route, recasting Uriagereka’s (1997) claim that binding is related to Case into Probe-Goal terms.⁴⁶ For this to be possible, we assume Uriagereka’s (1997) *Transparency Condition*:⁴⁷

(96) **TRANSPARENCY CONDITION**

In the absence of a more specific indication to proceed otherwise, where formal feature bags α and β are grammatically distinct, the speaker confines the range of α ’s context variable differently from the range of β ’s context variable.

[from Uriagereka 1997, cited from Uriagereka 2002a: 165]

Broadly, (96) amounts to this: if α and β are formally different (by means of Case; say, nominative vs. accusative), α and β are semantically different as well (i.e., obviative).

⁴⁶ See Cecchetto (2006) for a development of Chomsky’s (to appear) suggestion about Condition (C). I leave this condition aside, given its non-local nature.

⁴⁷ For the origins of (96), see Uriagereka (1988a: 478 and ff.).

After Multiple Agree (T_S , se , v^*) takes place, a complex dependency is formed between the subject, the clitic anaphor se , the functional heads C - T_S , and v^* : this collapses the arguments *Germán* and se so that they are interpreted as the same entity. From this perspective, *Germán* binds se through T_S , exactly as Chomsky (to appear) argues.

Notice that no problem arises for se and v^* not having their features valued in the v^*P phase, as long as they can do it in the CP phase. This is because they end up in v^*P 's edge, which, by the PIC, is not transferred.

As it turns out, this might explain, as Uriagereka & Gallego (in progress) suggest, why (102) is out: since *sí* cannot move to v^*P 's edge (not being a clitic, it does not move to SPEC- v^* , as per Torrego 1998a), it gets transferred without having been valued.⁵³

- (102) *Germán se afeitado a sí. (Spanish)
 Germán SE shave-3.SG to self
 'Germán shaves himself'

The only way to save (102) is by using the adjective *mismo*, which –we claim– can be used as Goal by *sí*, just like *il* and *there* probe their associates in Chomsky's (2004) analysis of expletives:

⁵³ Our account should be able to say why se is obligatory in binding configurations:

- (i) Juan *(se) afeitado a sí mismo. (Spanish)
 Juan SE shave-3.SG to self same
 'Juan shaves himself'

Uriagereka & Gallego (in progress) follow Torrego (1995b) in treating se as a clitic that licenses the Case of null *pro* in object position, just like accusative clitic *lo* licenses the Case of the strong pronoun *él* in (ii) (see Torrego 1995a; 1998a).

- (ii) Juan *(lo) vió a él. (Spanish)
 Juan CL-him see-PAST-3.SG to him
 'Juan saw him'

That se and lo are used to license structural Case is supported by the fact that anaphors within adjuncts do not allow se , as Torrego (1995b) notes.

- (iii) Juan *(se) desconfía de sí mismo. (Spanish)
 Juan SE distrust-3.SG of self same
 'Juan does not trust himself'
- (iv) Juan *(se) habla consigo mismo. (Spanish)
 Juan SE talk-3.SG with-self same
 'Juan talks to himself'

Obviously, I am taking *de sí mismo* and *consigo mismo* in (iii) and (iv) to be adjuncts of *desconfiar* (Eng. *distrust*) and *hablar* (Eng. *talk*) respectively. See chapter 4.

- (103) Germán se afeita a sí mismo. (Spanish)
 Germán SE shave-3.SG to self same-MASC.SG
 ‘Germán shaves himself’

Synthesizing, the Probe-Goal approach to binding just outlined amounts to (104):

(104) **PROBE-GOAL BINDING**

α binds β if they are both Goals of the same Probe; otherwise, α and β are obviative

[from Uriagereka & Gallego in progress]

I have claimed that our (104) can account for Condition (A) and Condition (B). The latter is trivially explained if subject and object have different Probes: T_S and T_O (or v^* , if one follows Chomsky).

The general picture can be seen in (105), where I depict the two binding scenarios relevant for the Probe-Goal approach of Uriagereka & Gallego (in progress):

- (105)
- a. $[_{CP} C [_{TP} \text{Subject } T_S [_{v^*P} t_{\text{Subject}} [\text{Object-}v^*] [_{VP} V t_{\text{Object}}]]]]$ Binding // Condition (A)
-
- b. $[_{CP} C [_{TP} \text{Subject } T_S [_{v^*P} t_{\text{Subject}} v^* [_{VP} V \text{Object}]]]]$ Obviation // Condition (B)
-

The case of Condition (A) is admittedly murkier, but it falls into place under the rather plausible assumption that anaphors are ϕ -defective –this allows T_S to agree with both subject and object, causing a formal and interpretive collapse.

Notice, quite importantly, that we are not saying that binding takes place if subject and object have the same ϕ -features –this is true in (106), yet *Mary* does not bind *that girl*.

- (106) *Mary saw that girl. (where *Mary* = *that girl*)

What is needed, actually, is for subject and object to *receive the same ϕ -value, assigned by a unique Probe: T_S*. With this background in mind, let us go back to subjunctive dependents.⁵⁴

Apart from long-distance obviation, another salient trait of subjunctive (and some uses of conditional and modal futures, as noted by Torrego 1983; 1984) concerns the process of *que* (Eng. *that*) deletion, which is in general barred in Spanish:⁵⁵

(107) “*que*” deletion (1)

- a. Espero [CP C llegue bien tu hermano] (Spanish)
 hope-1.SG arrive-SUBJ-3.SG well your brother
 ‘I hope your brother arrives well’
- b. Lamento [CP C te hayas quedado fuera] (Spanish)
 regret-1.SG CL-you have-SUBJ-2.SG left out
 ‘I regret you are out’
- c. Les rogamos [CP C se abrochen los cinturones] (Spanish)
 CL-to-you beg-1.PL SE fasten-SUBJ-2.PL the seatbelts
 ‘We beg you to fasten your seatbelts’

To the best of my knowledge, cases like (107), together with some rare cases brought up in Gallego (2003) involving relative clauses, are the only environments that systematically allow *que*-deletion in Spanish:⁵⁶

⁵⁴ In Uriagereka & Gallego (in progress) we follow Chomsky’s (1986b) adoption of Lebeaux’s (1983) insight about anaphors as elements which need to move to a position close to some element supplying them with ϕ -features.

As the reader may recall, Chomsky (1986b; 1993a) extends that analysis to English in a straight fashion, assuming that *self* moves to INFL in the covert component:

(i) [CP C [TP Subject *self*-T_S [_{v*P} t_{Subject} v* [VP V t_{self}]]]]

↑ _____ |

An appealing aspect of this abstract analysis is that it is actually forced by Chomsky’s (2000; 2001) PIC: if anaphors did not cliticize to v*, Multiple Agree would fail.

⁵⁵ See Giorgi & Pianesi (2004) and Poletto (2001) for exceptional cases of *che*-deletion in Italian, showing the same general properties: it is optional and only licensed by subjunctive.

Catalan, as far as I know, lacks *que*-deletion entirely. If this process involves (as argued in Gallego 2003; 2004a; 2004b; 2006b) direct verb movement to C, the Catalan pattern falls into place, since verb movement in Catalan is weaker than it is in Spanish, as we have seen.

⁵⁶ See Etxepare (1999) for a more detailed analysis of *que*-deletion in Spanish. At first glance, *que*-deletion appears not to have interpretive effects. However, Sánchez López (1999) notes the

(108) “*que*” deletion (2)

- a. Una propuesta [_{CP} C que tu padre dice [_{CP} C no es interesante]] (Spanish)
 a proposal that your father say-3.SG not be-3.SG interesting
 ‘A proposal that your father says is not interesting’
- b. Una persona [_{CP} con la que C Juan dice [_{CP} C se puede trabajar]] (Spanish)
 a person with the that Juan say-3.SG SE can-3.SG work-INF
 ‘A person that Juan says one can work with’

Curiously, preverbal subjects are disallowed if *que* is deleted. Gallego (2003) took this fact (first noted by Torrego 1984) to argue for verb movement to C in the case of *que* deletion, as indicated in (109):

(109)

- a. Lamento [_{CP} C_[TNOM] piense_i[_{TNOM}] [_{TP} T_{Si} eso_j[_{TACC}] [_{v*P} María_[TNOM] t_i t_j]]] (Spanish)
 regret-1.SG think-SUBJ-3.SG that María
 ‘I regret that María think that’
- b. *Lamento [_{CP} C_[T] [_{TP} María_j[_{TNOM}] T_{Si}[_{TNOM}] piense [_{v*P} t_j t_i eso_[TACC]]]] (Spanish)
 regret-1.SG María thinks-SUBJ-3.SG that
 ‘I regret that María think that’

In (109a) *piense* (Eng. *think-SUBJ*) moves from T_S to C in a direct fashion without launching the clitic *que* (Eng. *that*), the problem in (109b) following from the lack of valuation of C’s T feature: again, I took this degraded outcome to reinforce the idea that subject DPs cannot be used for valuation of C’s T (see chapter 2).

following contrast, which is due to the subordinating verbs *temer* (Eng. *be afraid of*) and *dudar* (Eng. *doubt*):

- (i) Temo (que) no venga Pepe. (Spanish)
 fear-1.SG that not come-SUBJ-3.SG Pepe
 ‘I am afraid that Pepe not come’
- (ii) Dudo (que) no tengas razón. (Spanish)
 doubt-1.SG that not have-SUBJ-3.SG reason
 ‘I doubt that you are not right’

[from Sánchez López 1999: 2628]

According to Sánchez López (1999), if *que* is dropped in (i) and (ii), negation in the embedded clause is interpreted in an expletive way.

That the verb moves to C in these cases might be supported by adverb placement. I have always regarded this test as highly suspicious, for we cannot be sure of where adjuncts are, but let us nevertheless suppose adverbs like *siempre* (Eng. *always*) are merged somewhere in the *v**P's edge and that they can also appear in the TP's (a sensible possibility, given their temporal/aspectual nature; see Bruccart 1994a).^{57 58}

(110)

- a. Luis (*siempre*) canta (*siempre*). (Spanish)
 Luis always sing-3.SG always
 'Luis always sings'
- b. Lamento (**siempre*) cante (*siempre*) Luis (*siempre*). (Spanish)
 regret-1.SG always sing-SUBJ-3.SG always Luis always
 'I regret that Luis always sing'

Aware of this and many more asymmetries of the interpretive sort between indicative and subjunctive dependents, Torrego & Uriagereka (1992) analyze the former in a paratactic-like fashion, with the subordinate clause being a completely independent chunk getting paratactically related to a hidden nominal, the real complement of indicative-taking verbs, as indicated in (111).⁵⁹

⁵⁷ Following Bruccart (1994a), in Gallego (2003), I also used *siempre* to show that the verb moves to C in interrogative matrix clauses:

- (i) [CP C [TP Inés_i *siempre*_j T_S lee [_v*P t_i t_j a Marías]]] (Spanish)
 Inés always read-3.SG to Marías
 'Inés always reads Marías'
- (ii) [CP A quién_j C lee_j [TP *siempre* T_S [_v*P Inés t_i t_j]]]? (Spanish)
 to whom reads-3.SG always Inés
 'Who(m) does Inés always read?'

In its unmarked position, *siempre* precedes the verb in declarative clauses. As (ii) shows, however, *siempre* follows the verb, a fact I took to signal T-to-C movement.

⁵⁸ To see the problems for taking adverbs as syntactic landmarks (in line with the Cinque-Pollock project), see Bobaljik (1999), Nilsen (1999), and Iatridou (1990; 2002). See Cinque (2004) for a reply to the arguments against adverbs occupying fixed positions.

⁵⁹ This idea goes back to Bello (1847), who analyzed (i) as in (ii):

- (i) Que la tierra se mueve alrededor del sol es cosa probada. (Spanish)
 that the Earth SE move-3.SG around of-the Sun be-3.SG thing proved
 'That the Earth moves around the Sun is a fact'
- (ii) Esto, que la tierra se mueve alrededor del sol, es cosa probada. (Spanish)
 this, that the Earth SE move-3.SG around of-the Sun, be-3.SG thing proved
 'This, namely that the Earth moves around the Sun, is a fact'

[from Bello 1874: §§ 316-319]

(111) *Indicative vs. Subjunctive dependents*

- a. Platón quiere -HYPOTAXIS- [CP C que Aristóteles lea a Sócrates] (Spanish)
 Plato want-3.SG that Aristotle read-SUBJ-3.SG to Socrates
 ‘Plato wants Aristotle to read Socrates’

- b. Platón dice [DP *pro*] -PARATAXIS- [CP que Aristóteles lee a Sócrates] (Spanish)
 Plato say-3.SG that Aristotle read-3.SG to Socrates
 ‘Plato says that Aristotle reads Socrates’

[from Torrego & Uriagereka 1992: 7]

Given the paratactic structure they assume, Torrego & Uriagereka’s (1992) analysis conceives wh-movement as having wh-phrases directly merged in the topmost SPEC-C, with intermediate steps being treated like resumptive pronouns. Be that as it may, I want to offer an alternative analysis that tries to be consistent with the T-to-C system entertained so far. In order to do that, I first need to expand on Pesetsky & Torrego’s (2007) analysis of raising.

Recall that in chapter 2 it was noted that Chomsky (2000; 2001) and Pesetsky & Torrego (2007) have a very different take on defectiveness: Chomsky (2000; 2001) argues it is ‘lack of some feature,’ whereas Pesetsky & Torrego (2007) think it is ‘lack of some value.’ I tentatively adopted the latter view, assuming that defectiveness, in the case of raising structures, follows from T_S having an unvalued T feature or not T feature at all. Both possibilities are repeated in (112):

(112) *Defective T configuration*

- a. [_{vP} seem *v* [_{TP} T_{Sdef} [_{v*P} EA_[T] $v^*_{[T]}$ [V IA]]]]]
 b. [_{vP} seem *v* [_{TP} T_{Sdef} [_{v*P} EA_[T] $v^*_{[T]}$ [V IA]]]]]

Again, let us stick to the less dramatic option: (112a). Moreover, as argued above, I assume that raising structures have a defective C layer. This results in (113):

(113)

- a. [CP C [_{TP} T_S [...]]] *control*
 b. [CP C [_{TP} T_S [...]]] *raising / ECM*

Assuming this view of defectiveness, I would like to extend the technical part of Pesetsky & Torrego's (2007) analysis of raising to subjunctive dependents. In particular, I want to defend the hypothesis that the T and TNS features of embedded C and T_S in subjunctive clauses come from Lex unvalued, and get a value from the *v**-T₀ complex in the subordinating clause.⁶⁰

Such an analysis is supported by the fact that there is a temporal connection of the *consecutio temporum* sort, as pointed out by Torrego & Uriagereka (1992), who note that whereas indicative dependent clauses may show any temporal specification (regardless of the matrix's), subjunctive cannot:

(114) *Indicative Dependents*

a. Platón dice [_{CP} C que Aristóteles {lee/leía/leerá} a Sócrates] (Spanish)

Plato say-3.SG that Aristotle read-{PRES/PAST/FUT}-3.SG to Socrates

'Plato says that Aristotle {reads/read/will read} Socrates'

b. Platón dijo [_{CP} C que Aristóteles {lee/leía/leerá} a Sócrates] (Spanish)

Plato say-PAST-3.SG that Aristotle read-{PRES/PAST/FUT}-3.SG to Socrates

'Plato said that Aristotle {reads/read} Socrates'

[from Torrego & Uriagereka 1992: 10-11]

(115) *Subjunctive Dependents*

a. Platón quiere [_{CP} C que Aristóteles {lea/*leyera/*leyere} a Sócrates] (Spanish)

Plato want-3.SG that Aristotle read-SUBJ-{PRES/PAST/FUT}-3.SG to Socrates

'Plato wants Aristotle to {read/read/will read} Socrates'

⁶⁰ This idea is not new, and here I am particularly building on Picallo (1984), who explicitly argues that subjunctive lacks Tense (more precisely, subjunctive is specified as [-Tense, +Agreement]):

The relation between the [Tense] specification of a subjunctive [CP] and that of its main clause may be compared to the relation between an anaphor and its antecedent. Inf_{sub}, failing to denote time, is assigned a value in relation to the time-frame specification of its subcategorizing predicate. The mark for [Tense] in the complement subjunctive clause can thus be considered as a syntactic consequence of the Tense in the higher sentence and the morpheme marking [\pm Past] in subjunctive clauses as analogous in some sense to the *-self* marker of anaphors. [from Picallo 1984: 88]

- b. Platón quería [CP C que Aristóteles {*lea/leyera/*leyere} a Sócrates] (Spanish)
 Plato want-PAST-3.SG that Aristotle read-SUBJ-{PRES/PAST}-3.SG to Socrates
 ‘Plato wanted Aristotle to {read/read/will read} Socrates’

[from Torrego & Uriagereka 1992: 10-11]

The process I have in mind goes, roughly, as indicated in (116). The key aspect is that C and T_S have their T and TNS features unvalued:

(116)

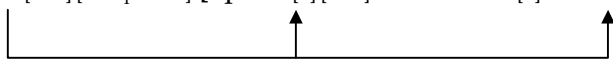
- a. P. quiere [T_O[T_{ACC}] [TNS:present] [que C_[T] [TNS] Aristóteles_[T] lea T_S[T] [TNS] [. . . a Sócrates]]]

b. P. quiere [T_O[T_{ACC}] [TNS:present] [que C_[T_{NOM}] [TNS:present] Aristóteles_[T_{NOM}] lea T_S[T_{NOM}] [TNS:present] ...]]

The process in (116) takes the matrix v^* -T_O complex to simultaneously value the T and TNS features of embedded C and T_S, and also the T feature of the subject *Aristóteles*.

It may strike the reader as odd for the subject to get an ACC value for its T feature, since, under standard assumptions, *Aristóteles* receives nominative Case. The problem is only apparent: what we know for sure is that *Aristóteles* and *lea* show [number] and [person] agreement, but this is not to say that *Aristóteles* gets nominative Case –it would, under Chomsky’s (2000; 2001) system, but not under Pesetsky & Torrego’s (2001; 2004), where Case and agreement are not the two sides of the same coin.

In sum, once all the pieces are put together, it turns out that subjunctives are, at the relevant level of abstraction, ECM configurations, this is what I wanted to highlight.

It goes without saying that the subjects of subjunctives do not raise, and they actually cannot, but this is not a problem, since the important syntactic connection with matrix v^* -T_O is established regardless, via long-distance Agree.

As I argued in chapter 1 (following Boeckx 2003a; 2003b; 2006b and Chomsky 2000; 2001), subject raising cannot take place because of ‘ ϕ -freezing,’ and, as we see,

subjunctive verbs fully agree with their subjects, precluding raising into the matrix clause.

If this analysis is on track, we are also in a position to assess the semantic phenomena (e.g., *consecutio temporum*, neg-raising, NPI licensing, etc.) that distinguishes indicative from subjunctive dependent clauses noted by Torrego & Uriagereka (1992). As we have just seen, the need for the embedded C-DP-T_S cluster to get a value for their T and TNS features delays the application of Transfer of the embedded clause, which might then allow Agree to operate within its boundaries (Agree, or whatever operation is responsible for the phenomena Torrego & Uriagereka 1992 discuss).

This analysis also provides an explanation for long-distance obviation. Actually, we can now invoke the same explanation given by Uriagereka (1997) in the case of local obviation. Recall that Condition (B) was accounted for by capitalizing on the fact that subjects and objects normally bear a different structural Case –this was, in a nutshell, Uriagereka’s (1997) insight. Obviation in (97), repeated below as (117), followed from *John* and *him* bearing different values for their T feature.

(117) John_[T_{NOM}] called him_[T_{ACC}]

Uriagereka’s (1997) proposal, together with the analysis of subjunctive dependents just put forward, allows us to explain long-distance obviation in the same fashion: the T feature of the two DPs are valued by different T heads. Therefore, *Germán* and *lo* are obviative in (118a) just like *Germán* and *pro* are in (118b).

(118)

- | | | | |
|---|--|----------------------------|-----------|
| a. *Germán _i lo _i | llamó. | <i>Local Obviation</i> | (Spanish) |
| | Germán CL-him call-PAST-3.SG | | |
| | ‘Germán called him’ | | |
| b. *Germán _i quiere | que pro _i llame. | <i>Non-Local Obviation</i> | (Spanish) |
| | Germán want-3.SG that pro call-SUBJ-3.SG | | |
| | ‘Germán wants him to call’ | | |

Note that (118b) does behave, in the relevant respects, like (119), a *bona fide* ECM structure:

(119) [_{CP} C [_{TP} Jack_i T_S believed {*him_i/himself_i}_j] [_{TP} t_j to be immoral]]]

[from Lasnik & Saito 1999: 9]

Of course, contrary to what we have in (119), binding is impossible in (118b), but this is due to two reasons: one, raising of *pro* into the main clause is impossible, and two, anaphors are barred in subject positions.

As we note in Uriagereka & Gallego (in progress), a binding account of this sort predicts that long-distance obviation should vanish the minute the embedded subject can not be a Goal of matrix T_O. As (120) shows, the prediction is borne out:⁶¹

(120)

a. Juan_i desea [_{CP} C que él_[*i/k] admire a Charlie Mingus] (Spanish)
 Juan wish-3.SG that he admire-SUBJ-3.SG to Charlie Mingus
 ‘Juan wants that he admire Charli Mingus’

⁶¹ There are some problematic Galician cases to this analysis, noted by Uriagereka (1988a):

- (i) O Rei Sabio espera de si mesmo que pro solucione ...
 the king wise expect-3.SG of SE same that solve-SUBJ-3.SG
 ... a paradoxa que lle puñeron os matemáticos. (Galician)
 the paradox that CL-to-him put-PAST-3.SG the mathematicians
 ‘The Wise King expects of himself to solve the paradox that the mathematicians put on him’
- (ii) Xan e máis María queren un do outro que pro cheguen ...
 Xan and more María want-3.PL one of-the other that arrive-SUBJ-3.PL
 ... a ricos e famosos. (Galician)
 to rich and famous
 ‘Xan and more so María want from one another to become rich and famous’

[from Uriagereka 1988a: 484]

A second objection to this analysis might come for structures like the ones in (ii), where, it would appear, the subject is raised from the embedded clause to the matrix’s bypassing an inflected boundary (see Bruccart 1994b for an analysis to this type of structures):

- (iii) Ya sé las traducciones de Chomsky que están a la venta. (Spanish)
 now know-1.SG the translations of Chomsky that be-e.PL to the sale
 ‘I know of the translations of Chomsky’s books that are on sale’
- (iv) Quiero a Juan trabajando. (Spanish)
 want-1.SG to Juan working
 ‘I want Juan to come’
- (v) Vi a María que cantaba. (Spanish)
 see-PAST-3.SG to María that sing-PAST-3.SG
 ‘I saw María singing’

I leave an explanation of these facts for future research.

b. Juan_i desea [_{CP} C que a él_{i/k} le gusta Charlie Mingus] (Spanish)
 Juan whis-3.SG that to him CL-to-him like-SUBJ-3.SG Charlie Mingus
 ‘Juan wants that he like Charlie Mingus’

[from Uriagereka & Gallego in progress]

The key for coreference to be possible in (120b) is the quirky nature of the DP occupying embedded SPEC-T_S: *a él* (Eng. *to him*). Our suggestion is that the dative preposition *a*, again, shields the strong pronoun *él* from T_O’s ϕ -Probe.

What about indicative dependents? Here I would like to argue that their paratatic-like behavior can be accounted for without necessarily adopting Torrego & Uriagereka’s (1992) analysis. In order to do that, I will appeal to Hornstein & Uriagereka’s (2002) *Reprojection*.

Specifically, let us assume that, in both indicative and subjunctive clauses, T_S raises to C, being spelled-out as *que* –that’s business as usual. From that moment on, the structure so far constructed (the would-be embedded CP) can be transferred or not, given the PIC.

We have seen that there is good reason to defend that Transfer does not apply in the case of subjunctive dependents: such CPs are defective, and have to wait until their C-T_S complex gets the relevant valuation from the matrix domain. What about indicative dependents? Their temporal specification seems to behave as ‘true tense’: its value never depends on the matrix verb’s: consequently, when T_S reaches the C head in the case of indicative dependents, a phase is completed and can be transferred. The difference might be stated as in (121), using the diachritic “*” to indicate completeness:⁶²

⁶² That embedded subjunctive clauses are not phases may be supported by the fact that no wh-phrase can land in SPEC-C and remain there (although see Suñer 1999 for some dialectal exceptions). Actually, I know of no embedded interrogative clause whose T_S is inflected in the subjunctive mood in Spanish, unless negation induces it, as in (i):

(i) No me importa [_{CP} qué libros_i C leas t_i] (Spanish)
 not CL-to me matter-3.SG what books read-SUBJ-2.SG
 ‘I don’t care what books you may may read’

(121)

a. C* selects T_{IND}

b. C selects T_{SUBJ}

I would like to push (121b) to the weak left-peripheral activity of subjunctives too. In fact, it seems to me that the fronting properties of subjunctives are nearly as limited as those of non-finite clauses. If one pays attention to the subjunctive tense paradigm, the conclusion is similar to the one we reached when considering the case of Catalan: subjunctive expresses less tense distinctions than indicative.

(122a) <i>Indicative Mood</i>	(122b) <i>Subjunctive Mood</i>
<i>Present tense</i> Yo canto I sing-1.SG	<i>Present tense</i> Yo cante I sing-SUBJ-1.SG
<i>Simple past tense</i> Yo canté I sing-PAST-1.SG	<i>Simple past tense</i> Yo cantase I sing-SUBJ-PAST-1.SG
<i>Imperfect past tense</i> Yo cantaba I sing-PAST-1.SG	
<i>Present perfect tense</i> Yo he cantado I have-1.SG sung	<i>Present perfect tense</i> Yo haya cantado I have-SUBJ-1.SG sung
<i>Anterior past tense *</i> Yo hube cantado I have-PAST-1.SG sung	
<i>Past perfect tense</i> Yo había cantado I have-PAST-1.SG sung	<i>Past perfect tense</i> Yo hubiera cantado I have-SUBJ-PAST-1.SG sung
<i>Future tense</i> Yo cantaré I sing-FUT-1.SG	<i>Future tense *</i> Yo cantare I sing-SUBJ-FUT-1.SG
<i>Future perfect tense</i> Yo habré cantado I have-FUT-1.SG sung	
<i>Conditional tense</i> Yo cantaría I sing-COND-1.SG	<i>Future perfect tense *</i> Yo hubiere cantado I have-SUBJ-PAST1.SG sung
<i>Conditional perfect tense</i> Yo habría cantado I have-COND-1.SG sung	

(*) Not used in present-day Spanish

This intuition is confirmed by different kinds of evidence that ultimately support the weak left-peripheral activity of subjunctive C.

(123) *Topicalization*

- a. Aristóteles creía [C*P C* que, *en cuanto a la Tragedia*, debía . . .
 Aristotle think-PAST-3.SG that, in respect to the Tragedy, must-PAST-3.SG
 . . . haber tres unidades] (Spanish)
 there-be-INF three units

‘Aristotle thought that, as far as Tragedy was concerned, there must be three units’

- b. *Aristóteles quería [CP C que, *en cuanto a la Tragedia*, . . .
 Aristotle want-PAST-3.SG that, in respect to the Tragedy,
 . . . hubiera tres unidades] (Spanish)
 there-be-SUBJ-PAST-3.SG three units

‘Aristotle wanted that, as far as Tragedy was concerned, there were three units’

[from Torrego & Uriagereka 1992: 16]

(124) *Focalization*

- a. Juan dijo [C*P C* que [*muchas cosas*_i [TP *pro* había visto t_i]]]! (Spanish)
 Juan say-PAST-3.SG that many things have-PAST-3.SG seen

‘Juan said that a lot of things he had seen!’

- b. *Juan quería [CP C que [*muchas cosas*_i [TP *pro* viera t_i]]! (Spanish)
 Juan wanted that many things see-SUBJ-3SG

‘Juan wanted a lot of things for him to see!’

[from Torrego & Uriagereka 1992: 17]

As for subjects, these can be focalized in Spanish, but, as pointed out by Picallo (1984), not in Catalan –arguably, a consequence of the micro-parameter I explored above:

(125) *Subject focalization*

- a. Lamento [CP C que [*JUAN*_i venga t_i]] (Spanish)
 regret-1.SG that JUAN come-SUBJ-3.SG

‘I regret that JOHN come’

- b. *Sento [CP C que [*EN JOAN*_i [vingui t_i]]] (Catalan)
 regret-1.SG that the JOAN come-SUBJ-3.SG

‘I regret that JOHN come’

[from Picallo 1984: 89]

Consider clitic left dislocation and speaker oriented adverbs next, where the same indicative-subjunctive asymmetry arises:

(126) *Clitic Left Dislocation*

a. Inés dijo [C*P C* que [los libros_i [TP pro los_i leyó t_i]]] (Spanish)

Inés say-PAST-3.SG that the books pro CL-them read-PAST-3.SG

‘Inés said that the books he read’

b. ?/??Inés quería [CP C que [los libros_i [TP pro los_i leyera t_i]]] (Spanish)

Inés want-PAST-3.SG that the books pro CL-them read-SUBJ-3.SG

‘Inés wanted the books for him to read’

(127) *Speaker oriented adverbs*

a. Juan dice [C*P C* que [francamente [TP el Deportivo ganará la Liga]]] (Spanish)

Juan say-3.SG that frankly the Deportivo win-FUT-3.SG the League

‘Juan says that frankly Deportivo will win the championship’

b. *Juan quiere [CP C que [francamente [TP el Deportivo gane la Liga]]] (Spanish)

Juan want-3.SG that frankly the Deportivo win-SUBJ-3.SG the League

‘Juan wants frankly for the Deportivo to win the championship’

With respect to covert phenomena (e.g., neg-raising, NPI’s licensing, QR, *wh-in situ*, etc.) it is possible that they follow from (121) as well: if subjunctive CPs are not phases, their domain extends to the matrix clause, which makes us expect a stronger syntactic connectivity between the embedded and the main clauses.

Plausibly, the lack of syntactic independence in subjunctive clauses might also explain why some cases of extraction improves with this mood, as can be seen in the examples in (128) and (129):

(128)

a. [C*P Qué libros_i C* le diste a Leticia [FP P para [CP que leyese t_i]]] ? (Spanish)

what books CL-to-her give-PAST-2.SG to Leticia for that read-SUBJ-3.SG

‘What books did you give Leticia for she to read (them)?’

- b. * $[_{C^*P}$ Qué libros_i C le diste a Leticia $[_{PP}$ P por $[_{CP}$ C que leíste t_i]])? (Spanish)
 what books CL-to-her give-PAST-2.SG to Leticia for-that read-PAST-2.SG
 ‘What books did you give Leticia because you read (them)?’

(129)

- a. $[_{C^*P}$ Qué_i C* estás cansado $[_{PP}$ P de $[_{CP}$ C que Juan haga t_i]])? (Spanish)
 what be-2.SG tired of that Juan do-SUBJ-3.SG
 ‘What are you tired of Juan doing?’
- b. ?? $[_{C^*P}$ Qué_i C* estás seguro $[_{PP}$ P de $[_{C^*P}$ C* que Juan hizo t_i]])? (Spanish)
 what be-2.SG sure of that Juan do-PAST-3.SG
 ‘What are you sure that Juan did?’

It is tempting to capture the weak connectivity manifested by indicative dependents by combining T-to-C movement and *Reprojection*. To be specific about it, suppose that upon merger with C*, T_S reprojects. If this is indeed the case, then we must give a motivation for such operation to take place and, furthermore, we must explain why it happens only with indicative dependents.

Firstly, I would like to argue that *Reprojection* works here in the same way as discussed by Hornstein & Uriagereka (2002): a binary predicate needs to have their dependents within its projection. The idea that, in the case at hand, T_S is the predicate should not be polemic: there is a general consensus in treating T_S as a binary predicate (see Demirdache & Uribe-Etxebarria 2000, following ideas by Stowell and Zagana).

As a matter of fact, I would like to go even further and claim that T_S embodies the existential quantifier \exists of the neo-Davidsonian framework (see Herburger 2000).⁶³

(130) $[_{C^*P}$ C* $[_{TP}$ $\exists = T_S$ $[_{v^*P}$ v^* . . .]]]

⁶³ See Higginbotham (1985) and Kratzer (1996) for similar ideas. See Irurtzun (2006; 2007) for an alternative proposal. In his analysis, the existential quantifier corresponds to Rizzi’s (1997) Fin. The main argument given by Irurtzun (2006) is that elements occupying the T_S position can also be focused:

- (i) A: I heard that John is married.
 B: No, he WAS married!

[from Irurtzun 2006: 93]

What (and where) are \exists 's arguments? I assume that v^*P corresponds to the restriction, as depicted in (131):

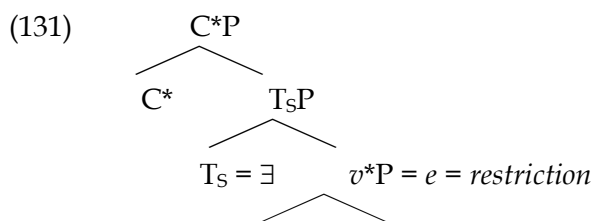

As the reader may see T_S has not taken the scope argument in (131). I want to put forward the idea that the right scope is obtained by means of T-to-C movement (in the spirit of Kempchinsky's 1987 insightful proposal about subjunctives, where T_S covertly moves to C). Once in C, T_S can scope over the full clause structure, being able to c-command any DP that has escaped from the v^*P :

(132) *Prior to T-to-C movement*

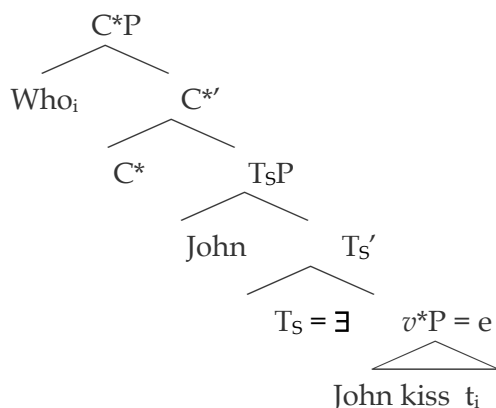

(133) *After T-to-C movement: Reprojection of T_S*

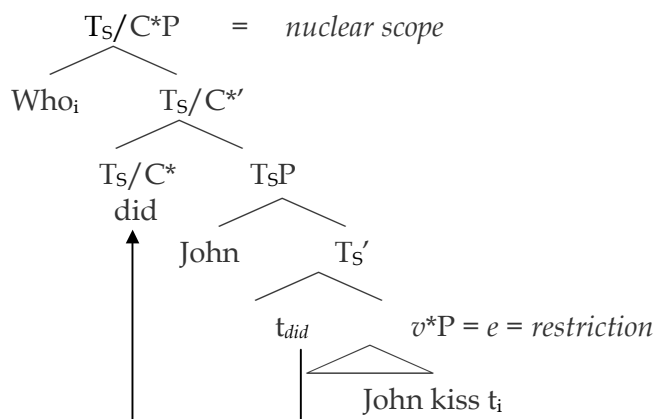

Interestingly enough, in Chomsky (1986a: 37) it is noted that tensed T_SPs create a barrier for movement. More particularly, Chomsky (1986a) points out that, for some speakers, (134a,b) are worse than (134c,d) –I do not use any symbol to indicate deviance, since Chomsky (1986a) does not use them either:

(134)

- a. [_{C*P} What_i C* did you wonder [_{C*P} to whom_j C [_{TP} John T_S gave t_i t_j]]]?
- b. [_{C*P} To whom_j C* did you wonder [_{C*P} what_i C [_{TP} John T_S gave t_i t_j]]]?
- c. [_{C*P} What_i C* did you wonder [_{CP} to whom_j C [_{TP} PRO to T_S give t_i t_j]]]?
- d. [_{C*P} To whom_j C* did you wonder [_{CP} what_i C [_{TP} PRO to T_S give t_i t_j]]]?

[from Chomsky 1986a: 36]

The following data, taken from Richards (2002), provide us with another relevant minimal pair: (135b) is out, but (135a) is not. Crucially, only in (135b) is the embedded clause inflected (in indicative).

(135)

- a. [_{C*P} What_i C* do you know [_{C*P} how_j C* [_{TP} PRO to repair t_i t_j]]]
- b. * [_{C*P} What_i C* do you know [_{C*P} how_j C* [_{TP} you repaired t_i t_j]]]

[from Richards 2002: 240]

It would thus appear that non-finite clauses (much like Spanish subjunctives) are more ‘transparent’ to extraction (see Torrego & Uriagereka 1992).

Similar facts are reported by Hornstein & Uriagereka (2002), who concentrate on the interaction between mood and negation. Whatever the specifics of the analysis turn out to be, it seems clear that even some instances of overt movement are degraded when *Reprojection* takes place:⁶⁴

⁶⁴ As Masaya Yoshida (p.c.) points out to me, it is possible that Hornstein & Uriagereka’s (2002) *Reprojection* has something to do with the status of Wh-islands, if wh-phrases also force a reprojection when moved to SPEC-C*.

(136)

a. [_{C*P} Qué_i C* no crees [_{CP} C que sea [t_i fácil]]]? (Spanish)

what not think-2.SG that be-SUBJ-3.SG easy

‘What don’t you think be easy?’

b. ?/??[_{C*P} Qué_i C* no crees [_{C*P} C* que es fácil t_i]]? (Spanish)

what not think-2.SG that be-SUBJ-3.SG easy

‘What don’t you think that is easy?’

[from Hornstein & Uriagereka 2002: 115]

(137)

a. [_{C*P} Por qué_i C* no crees [_{CP} C que sean fáciles las matemáticas t_i]]? (Spanish)

for what not think-2.SG that be-SUBJ-3.PL easy the mathematics

‘Why don’t you think maths be easy?’

b. ??/*[_{C*P} Por qué_i C* no crees [_{C*P} C* que son fáciles las matemáticas t_i]]? (Spanish)

for what not think-2.SG that be-3.PL easy the mathematics

‘Why don’t you think maths are easy?’

[from Hornstein & Uriagereka 2002:116]

The question that we must try to answer is: if T_S has to reproject in order to get their arguments, why doesn’t *Reprojection* apply in the case of subjunctive T_S? The answer lies in the (purely formal) need for embedded T_S to get a value from matrix’s T_S.⁶⁵ That blocks (or, more accurately, ‘postpones’) *Reprojection*.

This conclusion is compatible with Chomsky’s (1986a) observations:

Rizzi’s work suggest a further parametric difference between English and Italian, though in the English case, at least, there seems to be considerable variation among speakers [...] Suppose that the parameter involved in Rizzi’s material relates to the choice of IP vs. CP: that is, in the variety of English under consideration the “extra barrier” is tensed IP, and in Italian it is tensed CP. Choice of tensed CP rather than tensed IP as the value of the parameter adds no barrier in [(134)] [...] *It may be that the parametric variation involves not the distinction tense vs. infinitive but the distinction indicative vs. infinitive-subjunctive, or perhaps some factor involving nonrealized*

⁶⁵ Juan Uriagereka (p.c.) suggests to treat ϕ -complete C*-T_S (indicatives) as a binary quantifier, à la Herburger (2000), while ϕ -defective C-T_S (subjunctives) as a unary quantifier (i.e., an indefinite). That, as he notes, would explain the reprojection asymmetry, and it would make us investigate whether the weak/strong status of C-T_S is the *consequence* or the *cause* of the facts. I leave this aspect for future research.

subject [...] It seems that the major properties of wh-movement as discussed by Rizzi and others can be accommodated in terms of factors involving the clausal system CP, IP, with certain low-level parameters, though various questions remain. [from Chomsky 1986a: 37-39 –emphasis added, AJG]

In sum, I have suggested that Spanish (and, by extension, all NSLs) subjunctives constitute another instance of what Chomsky (2000; 2001) calls T_{def} . This is not obvious at first glance, because there seems to be a strong boundary between matrix and embedded clauses, but the hypothesis falls into place if all ECM structures need to be defined as such is long-distance Agree: the embedded subject receives an accusative value for its T feature from matrix T_O , although it fully agrees with the embedded verb.

4. A Note on SPEC- v^* / T_S and Preverbal Subjects

In chapter 2 we discussed Chomsky's (2001) claim that surface (discourse-oriented) effects arise at phase edges. As we saw, the idea is related to the assumption –crucial within Chomsky's system– that A and A-bar systems are distributed in a very concrete way: phasal specifiers (the edges) are A-bar positions, whereas non phasal specifiers are A positions (see Pesetsky 2007).

(138) [$_{C^*P}$ \bar{A} (edge) C^* [$_{TP}$ A T [$_{v^*P}$ \bar{A} (edge) v^* [$_{VP}$ A V]]]]]

We also considered Chomsky's (to appear) idea that the A/A-bar distinction is feature oriented (ϕ -features trigger A-movement, EFs do A-bar movement), which we dismissed in its most strict form, for one simple reason: namely, feature checking does not require movement. Consequently, every application of internal Merge was considered as A-bar, like every application of internal Merge can (potentially) give rise to an operator-variable chain.

Although such a hypothesis makes sense, empirical evidence indicates otherwise, as movement operations have been proved to differ with respect to tests such as weak cross-over, binding, control, or reconstruction, providing the well-known A/A-bar distinction. Here I would like to refine my previous argumentation by taking what is generally referred to as “A-movement” as a subtype of internal Merge that, though not

entirely motivated by, participates in ϕ -feature checking (see next section for final qualifications about this idea).

Another interesting issue investigated in chapter 2 concerns the fact that only some specifiers appear to be able to factually host syntactic objects. We just saw this in the case of Catalan, whose *Left Periphery* does not tolerate a mild focalization that abounds in Spanish. The paradigm in (139) below is intended to make the same point. As can be seen, the indefinite DP *alguien* (Eng. *someone*) can only stay still in some specifiers – though by assumption it moves through each and everyone of them (see Boeckx 2007).

(139) *Successive cyclic movement of “alguien”*

a. [_{C*P} C* [_{TP} T_S Parece [_{AuxP} haber [_{PrTP} sido [_{vP} arrestado *alguien*]]]]] (Spanish)

seem-3.SG have-INF been arrested someone

‘Someone seems to have been arrested’

b. ??/* [_{C*P} C* [_{TP} T_S Parece [_{AuxP} haber [_{PrTP} sido [_{vP} *alguien*_i arrestado t_i]]]]] (Spanish)

seem-3.SG have-INF been someone arrested

‘Someone seems to have been arrested’

c. ** [_{C*P} C* [_{TP} T_S Parece [_{AuxP} haber [_{PrTP} *alguien*_i sido [_{vP} t_i arrestado t_i]]]]] (Spanish)

seem-3.SG have-INF someone been arrested

‘Someone seems to have been arrested’

d. ** [_{C*P} C* [_{TP} T_S Parece [_{AuxP} *alguien*_i haber [_{PrTP} t_i sido [_{vP} t_i arrestado t_i]]]]] (Spanish)

seem-3.SG someone have-INF been arrested

‘Someone seems to have been arrested’

e. [_{C*P} C* [_{TP} *Alguien*_i T_S parece [_{AuxP} t_i haber [_{PrTP} t_i sido [_{vP} t_i arrestado t_i]]]]] (Spanish)

someone seem-3.SG have-INF been arrested

‘Someone seems to have been arrested’

The examples in (139) pose the question of why *alguien* (Eng. *someone*) can remain only in some specifiers. Following the argumentation in section 2, I take this to follow from morphological richness: those specifiers that can host syntactic objects are finite (morphologically richer) forms.

In what follows I want to address the status of SPEC-T_S in NSLs. The literature has pervasively argued that the SPEC-T_S position has both A and A-bar properties in NSLs

(see Barbosa 1995, Camacho 2005, Jaeggli 1982; 1984, Masullo 1992, Solà 1992, Uribe-Etxebarria 1992, and references therein). As just said, this is difficult to square with Chomsky's (2007; to appear) framework, for only phase heads qualify as A-bar. However, if internal Merge always yields an A-bar chain (as I claim), then there is a way to make the Spanish facts fall into place.

In Gallego (2004b; 2005), I tried to recast the A-bar status of SPEC-T_S in NSLs by arguing that *v**-to-T movement provided T_S with EFs.⁶⁶ If what I am pursuing here is tenable, the A-bar status of SPEC-T_S is compulsory the minute A-bar properties are a side-effect of internal Merge –and not of feature checking.

As said, SPEC-T_S in NSLs has been said to display A-properties, indicating φ -feature checking is involved. Consider (140), which shows that preverbal subjects (occupying SPEC-T_S, I assume) can bind and control:

(140) *Preverbal subjects: A-properties (1)*

- a. Juan_i quiere [C*P C* [TP PRO_i salir con María]] (Spanish)
 Juan want-3.SG go-out-INF with María
 'Juan wants to go out with María'
- b. [C*P C* [TP Juan_i T_S se_i afeitó [_v*P t_{Juan} *v** [DP a sí mismo_i t_i]]]] (Spanish)
 Juan SE shaves-3.SG to self same
 'Juan shaves himself'

An additional A-related property is agreement. As Uriagereka (2004) shows, a subject formed by two coordinated DPs only triggers number agreement obligatorily in preverbal position:⁶⁷

(141) *Preverbal subjects: A-properties (2)*

- a. {Han/Ha} llegado tu padre y tu hermano. (Spanish)
 have-{3.PL/3.SG} arrived your father and your brother
 'Your father and your brother have arrived'

⁶⁶ See Fortuny (2007) for exactly the opposite claim: namey, T_S has A-bar properties by inheritance from C.

⁶⁷ For an updated and detailed summary of the data, see Camacho (2003). The basic observation is a classical one that goes back to Andrés Bello, as M. Lluïsa Hernanz (p.c.) points out to me.

- b. Tu padre y tu hermano {han/*ha} llegado. (Spanish)
 your father and your brother have-{3.PL/3.SG} arrived
 ‘Your father and your brother have arrived’

[from Uriagereka 2004: 19]

Finally, (142) shows that preverbal subjects do not reconstruct (see Boeckx 2001 and references therein): another A-related trait.⁶⁸

(142) *Preverbal subjects: A-properties (3)*

- a. El xicot de la Maria_i no l_i’ha trucada. (Catalan)
 the boy of the Maria, not CL-her-have-3.SG called-FEM
 ‘Maria’s boyfriend has not called her’
- b. *No l_i’ha trucat el xicot de la Maria_i. (Catalan)
 not CL-her-have-3.SG called the boy of the Maria
 ‘Maria’s boyfriend has not called her’

As regards A-bar properties, Gallego (2004b; 2005) explored some phenomena showing that preverbal subjects are not clitic left dislocated topics, although they behave similarly in triggering a topic-like interpretation of the subject:⁶⁹

(143) *Preverbal subjects: A-bar properties*

- a. [_{C*P} C* [_{TP} María_i T [_{v*P} t_i v* baila]]] (Spanish)
 María dance-3.SG
 ‘María dances’ (=María is a dancer)
- b. [_{C*P} C* [_{TP} T Baila [_{v*P} María v*]]] (Spanish)
 dance-3.SG María
 ‘María dances’ (=It is María who dances)

⁶⁸ The same holds in Spanish. For additional arguments that preverbal subjects in NSLs target an A-bar position, see Alexiadou & Anagnostopoulou (1998). See Suñer (2003) for evidence in favor of the opposite claim in the case of Spanish.

⁶⁹ The same facts were previously, and independently, noted by Uriagereka (2002b). See also Raposo & Uriagereka (1995; 2002).

One difference between internal and clitic left-dislocated topics is that only the former can be an indefinite or a negative quantifier:

(144)

- a. [_{C*P} C* [_{TP} Ningún jugador del Madrid_i T_S merece_j [_{v*P} t_i t_j lo que gana]]] (Spanish)
 no player of-the Madrid deserve-3.SG the that win-3.SG
 ‘No Real Madrid player deserves what he earns’
- b. *[_{C*P} Ningún jugador del Madrid_i, C* [_{TP} t_i T_S merece [_{v*P} t_i lo que gana]]] (Spanish)
 no player of-the Madrid, deserve-3.SG the that win-3.SG
 ‘No Real Madrid player, he deserves what he earns’

The implementation in Gallego (2004b; 2005) therefore departed from Ordóñez & Treviño’s (1999) analysis, who subsumed preverbal subjects within the list of clitic left-dislocated elements. For these authors, the preverbal elements in (145) all occupy the same left-dislocated position: SPEC-Top.⁷⁰

(145)

- a. [_{TopP} Juan_i [_{TP} T_S le dio [_{v*P} t_i t_j las llaves a Pedro]]] (Spanish)
 Juan CL-him give-PAST-3.SG the keys to Pedro
 ‘Juan, he gave the keys to Pedro’
- b. [_{TopP} Las llaves_i, [_{TP} T_S se las_i dio_j [_{v*P} Juan t_j a Pedro t_i]]] (Spanish)
 the keys, SE CL-them give-PAST-3.SG Juan to Pedro
 ‘The keys, Juan gave to Pedro’
- c. [_{TopP} A Pedro_i, [_{TP} T_S le_i dio_j [_{v*P} Juan t_j t_i las llaves]]] (Spanish)
 to Pedro, CL-him give-PAST-3.SG Juan the keys
 ‘To Pedro Juan gave the keys’

[from Ordóñez & Treviño 1999: 40]

Although I agree that there are some similarities between them, it seems to me that a full parallelism between objects and subjects in preverbal position cannot be established: while the former must be clitic left-dislocated, the latter must not.

⁷⁰ This analysis shares some aspects with Rosselló’s (2000). Rosselló (2000), however, argues that the preverbal subject is directly generated in SPEC-T_S, with an argumental *pro* in SPEC-*v**. Her analysis does not clarify how preverbal subjects receive Case and theta-role, or how they are related to the *v*P* internal *pro*.

Rizzi (2006) has recently held the same view. In his analysis, preverbal subjects move to a dedicated position sandwiched between the T_SP and his *Left Periphery* in order to satisfy the EPP₂ *qua* criterion: the SubjectP. Importantly, *Subject Criterion* and *Topic Criterion* differ: they both convey “aboutness” (this is, broadly, what topics and preverbal subjects share), but only the latter needs “D-linking” (see Pesetsky 1987):

What special interpretive property should be associated to the EPP position? One often mentioned idea is that subjects are «topic-like» in some sense. *A complete assimilation of subjects and topics is much too coarse for many reasons*: even in a null subject language like Italian preverbal subjects are possible in “out of the blue” contexts (e.g., as answers to “what happened?” type questions), both in active and passive structures [...] [W]hile in such contexts *bona fide* topics, expressed by Clitic Left Dislocation in Italian, are not felicitous [...] Still, *subject and topic have something in common*: some kind of predication is involved in both cases, a process selecting an argument as the starting point of the event description, and expressing the event as somehow involving that argument. Following a rather standard terminology, we will call this relation “aboutness” [...] [T]he two notions differ in that *D(iscourse)-linking is a necessary component of Topics [...] [B]ut not of subjects.*

[from Rizzi 2006: 121-122 -emphasis added, AJG]

Behind Rizzi (2006) *Subject Criterion* lays an interesting trait: the discourse-oriented interpretation of preverbal subjects in NSLs. This is important, since that type of semantics is related to edges by Chomsky (2001):

(146) The EPP position of a phase *Ph* is assigned Int

[from Chomsky 2001: 33]

Chomsky (2001) applies (146) to *v** in order to account for *Object Shift*, a particular operation promoting objects to *v**'s edge (see next section). In Gallego (2004b), I pushed the same logic to T_S in order to strengthen its phasal status, arguing that the relevant interpretation was not specificity (preverbal subjects do not have to be specific), but a categorical/topic-like interpretation (see Raposo & Uriagereka 1995; 2002 and Uriagereka 2002b), involving a species of *Subject Shift*. The consequences of applying internal Merge to subjects can be seen (143) above: when the subject is preverbal it is interpreted as a topic; when it is preverbal, as a focus.

Summarizing, there seems to be good evidence that SPEC-T_S in NSLs displays both A and A-bar properties, a scenario compatible with the idea that any application of

internal Merge (potentially) gives raise to A-bar effects. Actually, that every application of internal Merge can trigger semantic effects is reinforced by the examples in (147), which, once again, instantiate the same topic-focus distinction of (143).

(147)

a. [_{C*P} C* [_{TP} Juan_i T_S fue [_{vP} v detenido t_i]]] (Spanish)

Juan be-PAST-3.SG arrested

‘Juan was arrested’

b. [_{C*P} C* [_{TP} T_S Fue [_{vP} v detenido Juan]]] (Spanish)

be-PAST-3.SG arrested Juan

‘Juan was arrested’

The important thing to note about these examples is that there is no strong phase, as Iván Ortega-Santos observes through personal communication. Since the *Phase Sliding* analysis put forward in Gallego (2005) adopted Chomsky’s (2001) claim about the role played by edges, I would not be able to explain why subjects in (147) get the same discourse-oriented contrasts that those in transitive sentences: there is not phase to slide, so there is not edge for subjects to move to.

This, no matter how we put it, goes against phases being characterized in terms of semantic effects arising at their edges, but it is still consistent with phases being characterized in terms of uninterpretable morphology deletion, in accord with the Phase Condition.

Finally, I want to address the question of how the interpretive effects of preverbal and post-verbal subjects are formally captured. As we have seen, there is a general agreement in regarding preverbal subjects as ‘topics’ and post-verbal ones as ‘foci’ (see Uriagereka 2002b).

In Chomsky’s (2001; 2004; 2007; to appear) system, discourse semantics effects follow from elements occupying a phase edge, under (146): this fits with the phasal status of *v*/TsP*, but does not say much in the case of post-verbal subjects, for these no longer occupy an edge after *Phase Sliding*. In order to overcome this tension, I would

like to suggest a modification of the v^*P structure so far entertained. In particular, I would like to argue that the EA is first-Merged within the VP, as (148) shows:

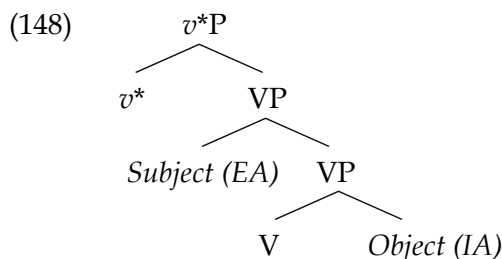

The configuration in (148) goes back to original ideas by Fukui & Speas (1986), Kitagawa (1986), Koopman & Sportiche (1991), Sportiche (1988), and Hale & Keyser (1993) suggesting that subjects are a VP adjunct/specifier. Ever since, it is widely accepted that EAs are base-generated in a position internal to the VP, a working hypothesis that has come to be known as the *VP Internal Subject Hypothesis* – ‘internal,’ of course, in the relevant sense, not in Hale & Keyser’s (2002).

Although the *VP-Internal Subject Hypothesis* is clear about EAs being generated in a position close enough to the verbal predicate, it is not clear about *where* exactly.⁷¹

From the mid 90s, this hypothesis stopped applying to a *lexical projection* (VP), and EAs were taken to be generated internally to a *functional projection*: the v^*P . The v^*P was first introduced by Chomsky (1995b: 315), who built on both Hale & Keyser’s (1993) and Larson’s (1988) proposals concerning a more articulated VP-internal structure, with multiple layers (i.e., Larson’s 1988 *shells*). Here I would like to adopt the unusual v^*P configuration in (148):⁷² with Chomsky (1995b; 2000; 2001; to appear), I agree that

⁷¹ This is confirmed by Noam Chomsky through personal communication (see section 5.3. below for more discussion):

The really difficult question is {EA, YP}. But there are so many problems with that construction that I suspect it’s wrong. Thus, why doesn’t it ever move as a unit? Why does something apparently have to extract from it (there are proposals, but none of them works, as far as I can see). I suspect that Ken Hale is right, and EA appears somewhere else –I don’t know where.

⁷² With Harley (1995; 2002) and Mateu (2002), I depart from the view of complex predicates as containing two subevents (for example, *cause* and *become*). Minimal pairs like (i) and (ii) are thus dealt with by assuming that the flavor of V is different: *cause* in (i), *become* in (ii).

- (i) John broke the glass.
- (ii) The glass broke.

there is a v^* , but I would like to claim that its only role is that of bearing inflectional information (the ϕ -features).⁷³

Furthermore, this yields more parallelism with the C*P phase, as there is no element analogous to EAs being externally merged as C*'s specifier: under this hypothesis, C* and v^* are the locus of ϕ -features, and of ϕ -features alone –they do not encode any semantic primitive (e.g., *cause*, *be*, etc.).

Given (148), the idea that all semantic effects of the discourse type arise from internal Merge is tenable: in particular, the focus and topic readings of post-verbal and preverbal subjects could derive from subjects moving to SPEC- v^* and SPEC-T_S respectively:

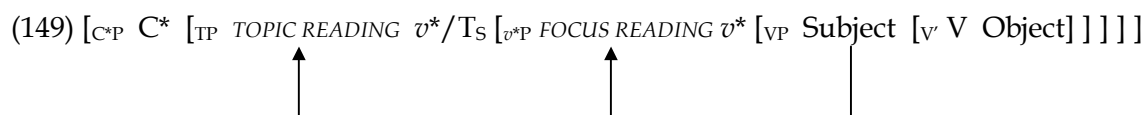

But even if the intuition behind (149) is on the right track, we need to regulate how topic and focus readings arise: Chomsky's (146) does not help in this respect, nor does (149) –and we certainly do not want for interpretations to arise at random. In other words: how do we know for sure that a topic reading is achieved in preverbal, and not post-verbal, position? (149) stipulates it.⁷⁴

The analysis I want to pursue here builds on Raposo & Uriagereka's (1995; 2002). To be concrete, I adopt Raposo & Uriagereka's (1995; 2002) idea that discourse-oriented interpretations emerge as an effect of *contextual grounding*.

In line with Mateu (2002), I take it that the presence of the EA *John* in (i) forces the system to assign V the *cause* flavor, a decision being done at the end of the v^*P phase, when the entire configuration is evaluated. This conclusion is in the spirit of Chomsky's (1981) and Marantz's (1984) idea that the external theta-role is assigned by the VP in full, in a configurational fashion.

⁷³ Chomsky (1995b) did adduce a good empirical reason to endorse the idea that EAs were base-generated in SPEC- v^* : *Burzio's Generalization*. If v^* encodes accusative Case, it makes sense for EAs receiving the /Agent/ theta-role to be directly related to v^* as well. However, this argument lost some strength the minute Chomsky (2001) argued for a weak variety of v^* (namely, v) introducing unaccusative structures.

⁷⁴ A different route would be to take a cartographic approach, where readings follow from there being dedicated semantic projections –actually, note that (149), unless qualified, is admittedly 'cartographic' in some sense.

(151)

a. [_{C*P} C* [_{TP} Juan_i (X) T_S escribe_j (Y) [_{v*P} t_i t_j]]] *Categorical/Topic Reading of "Juan"* (Spanish)

Juan write-3.SG

'Juan writes' (=Juan is a writer)

b. [_{C*P} C* [_{TP} T_S Escribe_i (Y) [_{v*P} Juan (X) t_i]]] *Thetic/Focus Reading of "Juan"* (Spanish)

write-3.SG Juan

'Juan writes' (= It is Juan who writes / Juan is writing now)

In the preceding lines I have addressed the hybrid (both A and A-bar) nature of SPEC-T_S in NSLs. Attention has been paid to the semantic effects displayed by subjects, which, from the perspective entertained here, do not necessarily follow from Chomsky's (2001) analysis of phase edges, but rather from the combination of internal Merge and the existence of contextual grounding.

5. Residual Object Shift in Romance

When introducing the operation Agree in chapter 1 I considered the details of what Chomsky (2000) calls *defective intervention effects*. In this section I point out one empirical problem for Chomsky's (2000; 2001; 2004; to appear) orthodox version of *Phase Theory*: VOS structures in NSLs. Building on Ordóñez's (1998b) work, I will claim that this type of sentences, if derived by internal Merge of the object above the subject (as Ordóñez 1998b argues), poses a problem for nominative Case assignment. The facts to be discussed will reinforce the syntactic status of verb movement *Phase Sliding* advocates for.

First, let us recall the specifics of Chomsky's (2000; 2001) Probe-Goal framework:

(152) CONDITIONS ON AGREE

- a. Probe and Goal must be active for Agree to apply
- b. Agree divides into Match and Valuation
- b. Probe must contain a full set of features (it must be ϕ -complete) to delete the uninterpretable FF of matched Goal

[from Chomsky 2001: 6]

What I am interested in here is the notion of ‘activity,’ which was related to feature interpretability in chapter 1: uninterpretable features (e.g., Case in nominals) render syntactic objects ‘active.’ Importantly, when a value is provided, syntactic objects are ‘frozen in place,’ invisible to further computational operations.

I further noted that the logic of freezing is relevant for features like Case, but not, say, for the φ -bundle of nominals: these remain ‘active’ no matter what, because they are interpretable. All in all, I assumed (153):

(153) **FREEZING EFFECT (non-final version)**

DPs whose Case has been checked are rendered computationally inert, but their interpretable FF remain ‘visible’ for Match, triggering *defective intervention effects*

I already pointed out that it is odd for Case to be responsible for freezing in Chomsky’s (2000; 2001) system: if Case is assigned after Agree takes place, then it is not accurate to say that its absence freezes DPs. Facts are more naturally described under Pesetsky & Torrego’s (2001; 2004) proposal, for there is a Case feature (that is, a T feature) that participates in Probe-Goal dependencies.

Building on Boeckx (2006b), I want to refine (153) even more, arguing that freezing is to be understood as a combination of both Case valuation and full checking of φ -features. I do this because if freezing is solely related to feature checking, then one would expect for freezing to apply in base-positions, before movement. However, there is substantial evidence that freezing takes place in derived positions, the ones typically associated to A-movement. Given my previous assumptions, I will conceive A-movement as *an instance of internal Merge involving φ -feature checking –and, more precisely, [person] checking*. In this respect, I follow Boeckx (2006b) in that [person] checking cannot be done at a distance, by standard Agree, requiring overt displacement instead (we will see why and how).

Accordingly, I assume that *freezing occurs in those derived positions where [person] checking takes place*:

(154) **FREEZING EFFECT (final vesion)**

A DP is frozen when . . .

- a. it values its Case feature, and
- b. it participates in [person] checking

With these qualifications done, let us go back to defective intervention effects. The literature is replete with studies about the particular type of locality matters that intervention effects deal with (see Lasnik & Boeckx 2006, Hiraiwa 2005, Rizzi 1990; 1997; 2001a; 2004, and Ura 1996, to mention but a few). The basic idea is easy to spell-out: whenever β , with a feature F, appears in the command path between K and δ (both of them bearing F), β blocks Agree (K, δ).

What intervention amounts to, graphically, is (155), a violation of Chomsky's (1995b) MLC:⁷⁸

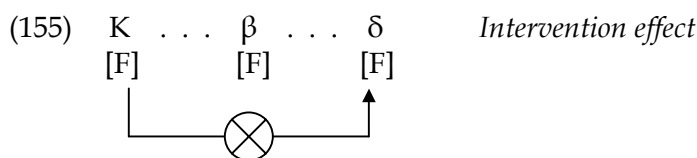

In chapter 2 it was also indicated that whereas in Rizzi's (1990; 2004) framework intervention is related to criterial features, Chomsky (to appear) restricts it to φ -features. A typical case of intervention discussed by Chomsky (2000; 2001) is the one created by DPs which have already been assigned a Case value (Goal₁), but nonetheless block Agree between a Probe and Goal₂:



As noted by different scholars, an obvious problem to the idea in (156) is posed by participial and *Object Shift* structures (see Chomsky 2001 and Frampton et al. 1999 for discussion). Consider first participial structures:

⁷⁸ See chapter 4 for more on A-bar related intervention effects.

(157) [_{v*P} Max *v** expected [someone to be [_{PrtP} Prt killed *t_{someone}*]]]

[from Frampton et al. 1999: 4]

Assuming participles bear both Case and ϕ -features, Frampton et al. (1999) point out that Chomsky's (2000; 2001) system wrongly predicts an intervention effect in structures like (157). The problem is as follows: the participial head Prt gets its ϕ -features valued by *someone* (which is then raised to SPEC-Prt), but ends up with no value for its Case feature, since the object intervenes.⁷⁹

The problematic configuration is pictured in (158):

(158) [_{v*P} Max *v** expected [someone to be [_{PrtP} Prt killed *t_{someone}*]]]

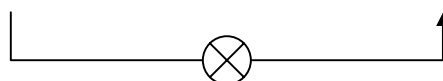

intervention

What we need for Prt to check its Case is the configuration in (159), where *v** does not only match *someone*, but keeps on scanning until it does Prt too, in a 'multiple' fashion. Crucially, this goes beyond the stiff logic of (155).⁸⁰

(159) [_{v*P} Max *v** expected [someone to be [_{PrtP} Prt killed *t_{someone}*]]]



Consider the second problematic situation: *Object Shift*.

(160) [_{C*P} C* [_{TP} Jólásveinarnir_i borðuðu_j T_S [_{v*P} búðinginn_j [ekki *t_i* *v** *t_j*]]]] (Icelandic)

the-Christmas-trolls eat-PAST-3.PL the-pudding not

'The Christmas trolls did not eat the pudding'

[from Bobaljik & Jonas 1996: 195]

⁷⁹ Frampton et al. (1999) assume Chomsky's (2000; 2001) theory of Case, where ϕ -Probes are responsible for assigning structural Case. I do not change this here, as I am reproducing their argument.

⁸⁰ Similar blocking effects can in principle be induced by elements like *v** (in passives whose object remains *in situ*) or *there*-type expletive sentences. It seems, though, that these elements do not block long-distance Agree, which could be related to their ϕ -defective status.

Abstracting away, the relevant offending configuration is (161) (assuming, for expository purposes, that subjects are first-Merged as SPEC- v^*):

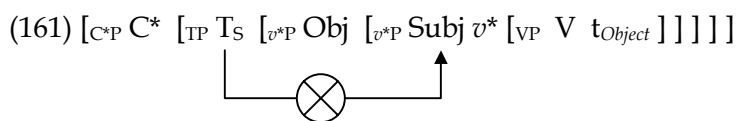

In Chomsky (2001), it is argued that the syntactic structure in (161) is not restricted to *Object Shift* of the Icelandic sort, but must be extended to all languages in object wh-movement situations. That is, by the PIC, object wh-phrases must pass through SPEC- v^* before reaching SPEC- C^* . When the object (*what* in 162) is in SPEC- v^* , the troublesome scenario in (161) emerges:

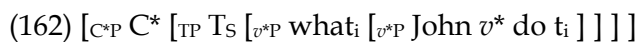

Notice that the configuration in (162) should give rise to intervention effects: when in SPEC- v^* , *what* is a potential intervener for Agree (T_S , *John*).

Historically, the problem with (161) goes back to the configuration in (163), adapted from Chomsky (1993a). The key aspect of (163) is the object DP: by the end of the derivation it must move to the specifier of an object-related functional projection dedicated to accusative Case checking outside the VP (say, for concreteness, Agr_oP), but in order to do so, it must bypass the *in situ* subject, therefore violating minimality:⁸¹

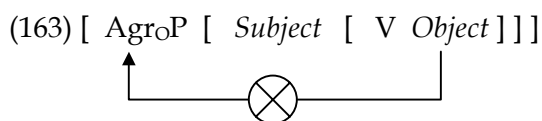

A second problem, related to the one in (162), is found in languages where the object raises overtly. In those cases, the subject must subsequently bypass the shifted object in order to reach its own Case checking position (Agr_sP in Chomsky 1993a).



⁸¹ As Lasnik & Boeckx (2006: 120) point out, the problem goes away the moment the Case checking position for objects is placed below the base position of subjects. See chapter 4.

Basically for these reasons, Chomsky (2000; 2001) assumed a mechanism of *equidistance*.

(165) EQUIDISTANCE PRINCIPLE (non-final version)

Terms of the minimal domain (= *edge*) of H are “equidistant” to probe P⁸²

[from Chomsky 2000: 122 & 130; 2001: 27]

As can be seen, the technical advantage of equidistance is that it allows for some MLC violations to be overridden. In a structure like (166), for instance, it does not matter whether XP c-commands YP (therefore being closer to a higher Probe): equidistance makes XP and YP fuse on locality grounds.

(166)

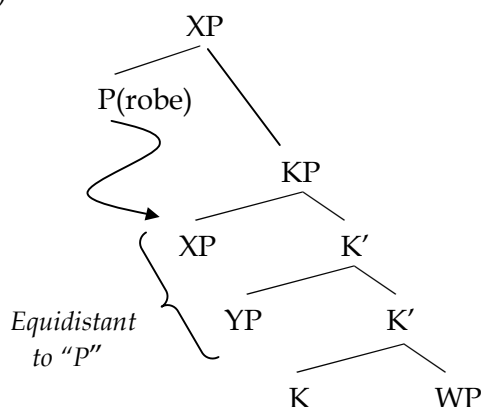

Equidistance provided, T_S can agree with *John* in (162) ‘ignoring’ the shifted object, *what*.

From a different perspective, Chomsky (2001) argues that the key to (162) has to do with the fact that the *wh*-phrase leaves no phonological material behind: since only heads of (both A and A-bar) chains give rise to intervention effects, the intervention problem vanishes if *what* has moved to SPEC-C by the end of the C*P phase. Differently put: the system does not care about the processes in a step-by-step view: it restricting its attention to the stage of the derivation in which evaluation occurs, the phase level.

⁸² Where *minimal domain* of H = *residue* of H. See chapter 1.

I will argue for a micro-parameter drawing a dramatic line between these possibilities: while all NSLs allow for the SVO order, only some of them can display VOS (French cannot, and in Italian it is marginal, according to Belletti 2004), finally, E.Portuguese, Galician, and Spanish are the only ones allowing the VSO pattern.

In what follows I explore those patterns which manifest parametric restrictions in NSLs: VOS and VSO. I will relate this state of affairs to the scenario we found when considering the *F Parameter* –the fact that some NSLs have a stronger type of verb movement, and, as a consequence of it, a more active *Left Periphery*. If my reasoning is tenable, I believe this constitutes additional evidence for the special (phasal) status of C and *v**. Let us investigate VOS sentences first.

5.1. VOS in NSLs

Picallo (1998) observes that Catalan transitive sentences allow SVO and VOS orders, but not the VSO one (see also Ordóñez 1997; 1998b; 2005, Solà 1992, Vallduví 1990, and references therein):

(170)

- | | | | | |
|----|---|-------------------|-----|-----------|
| a. | En Joan fullejava | el diari. | SVO | (Catalan) |
| | the Joan browse-PAST-3.SG the newspaper | | | |
| | ‘Joan was browsing the newspaper’ | | | |
| b. | Fullejava | el diari en Joan. | VOS | (Catalan) |
| | browse-PAST-3.SG the newspaper the Joan | | | |
| | ‘Joan was browsing the newspaper’ | | | |
| c. | *Fullejava | en Joan el diari. | VSO | (Catalan) |
| | browse-PAST-3.SG the Joan the newspaper | | | |
| | ‘Joan was browsing the newspaper’ | | | |

[from Picallo 1998: 228-229]

VOS sequences are fine in E.Portuguese, Galician, and Spanish, but impossible in French (see Kayne & Pollock 2001 and Ordóñez 1997), and, according to Belletti (2004), marginal in Italian, being licensed only if the appropriate discourse conditions are met.

In particular, for (171a) to be possible in Italian, it should be the answer to the question *Qui capirà il problema?* (Eng. *Who will understand the problem?*) –the same extends to (171b) and (171c):

(171)

- a. ??Capirà il problema Gianni. (Italian)
 understand-FUT-3.SG the problem Gianni
 ‘Gianni will understand the problem’
- b. ??Ha chiamato Maria Gianni. (Italian)
 have-3.SG called Maria Gianni
 ‘Gianni has called Maria’
- c. ??Ha letto il romanzo Gianni. (Italian)
 have-3.SG read the novel Gianni
 ‘Gianni has read the novel’

[from Belletti 2004: 34]

Belletti (2004) argues that VOS structures can be rescued by a derivation where the VO sequence is interpreted as a topic. Adopting a cartographic approach, Belletti claims that the VO chunk moves to a *v**P internal specifier of a Topic projection, while the subject undergoes internal Merge to the specifier of a Focus Phrase. To be precise about it, Belletti (2004) assumes a remnant-movement analysis, as indicated in (172):⁸³

(172)

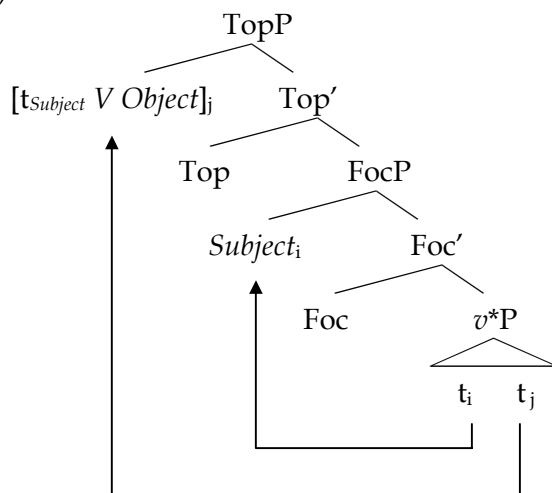

⁸³ The same analysis, involving subject movement to a Focus projection was first proposed by Ordóñez (1997) for Spanish.

A crucial aspect of this derivation is that the object does not c-command the subject, as it is too ‘buried’ in the structure. Belletti (2004) provides the evidence in (173) to make this point:⁸⁴

(173)

A: Chi ha salutato Gianni? (Italian)

who have-3.SG greeted Gianni

‘Who greeted Gianni?’

B: *Hanno salutato Gianni_i i propri_i genitori. (Italian)

have-3.PL greeted Gianni the own parents

‘His own parents have greeted Gianni’

[from Belletti 2004: 36]

The data in (173) show that the object *Gianni* does not c-command the anaphor *propri* (Eng. *own*) within the subject DP *i propri genitori* (Eng. *the own parents*).

In turn, (174) shows that the topicalized VP can reconstruct into its base position if the subject is a quantified DP such as *tutti i candidati* (Eng. *all the candidates*):

(174)

A: Chi ha baciato la propria moglie? (Italian)

who have-3.SG kissed the own wife

‘Who kissed his own wife?’

B: Hanno baciato la propria moglie tutti i candidati. (Italian)

have-3.PL kissed the own wife all the candidates

‘All the candidates have kissed their own wife’

[from Belletti 2004: 36]

Let us suppose that there is in fact the possibility for VOS sequences to be derived by topicalizing the VP, as Belletti (2004) contends.⁸⁵ Apart from Belletti’s (2004)

⁸⁴ Belletti (2004: 48 fn.55) acknowledges disagreement with Anna Cardinaletti (see Cardinaletti 2001b; 2004), who follows Ordóñez (1998b) in analyzing VOS sequences as a case of object scrambling over the subject. See next section.

analysis, I would like consider the specifics of Ordóñez's (1998b) account, who proposes that VOS structures obtain by scrambling the object to a position c-commanding the subject.⁸⁶

In sum, the two options for deriving VOS are as depicted in (175), where I put aside some assumptions made by Belletti (2004) and Ordóñez (1998b):⁸⁷

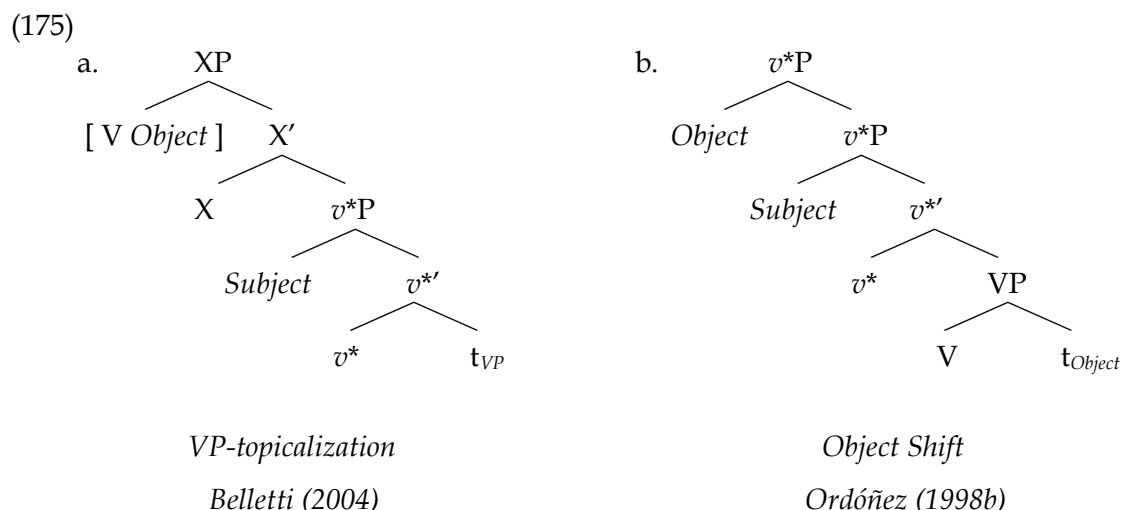

Different pieces of evidence reinforce Ordóñez's (1998b) analysis, at least for Spanish.⁸⁸ For one thing, shifted objects can bind within post-verbal subjects:⁸⁹

⁸⁵ VP-topicalization (e.g., *Kiss Mary, John did*), just like VP ellipsis (see Depiante 2001a; 2001b), is not attested in Spanish (but see Vicente 2007 for an analysis of fronted infinitivals such as *Ganar dinero, María gana* –Eng. (to) win money, María wins) in terms of VP fronting), so postulating it in the case at hand seems problematic.

⁸⁶ Under Rizzi's (1982) analysis the subject in VOS sentences should be considered a case of extraposition (or an 'afterthought'; see Chomsky 2004). The fact that it bears the main stress provides independent evidence that either it has remained *in situ* or else it is the most deeply embedded element (see Cinque 1993).

⁸⁷ In (175a) I depart from Belletti's (2004: 34-38) implementation with respect to what amount of structure is topicalized: for Belletti (2004), it is *v*P* (although she does not provide evidence from reconstruction; see Huang 1993), while the analysis in (175) assumes it is the VP. Nothing crucially hinges on this, for what matters is that c-command between subject and object fails.

⁸⁸ This does not mean that Spanish necessarily lacks the other option. See Vicente (2007) for evidence that structures like (i), dubbed (*full*) *VP clefting* by this author, involve VP topicalization.

(i) Leer el libro, Juan lo ha leído. (Spanish)
 read-INF the book, Juan CL-it have-3.SG read
 'As for reading the book, Juan has read it'

[from Vicente 2007: 60]

⁸⁹ The behavior of quantifier *cada* (Eng. *each*) differs from *todos*'s (Eng. (agreeing) *all*), and even more so from *todo*'s (Eng. (non-agreeing) *all*) with regards to binding. Descriptively, it seems

(176) *Variable binding (1)*

- a. Ayer visitó a cada chico_i su_i mentor. (Spanish)
yesterday visit-PAST-3.SG to each boy his mentor
'His mentor visited each boy yesterday'
- b. *? Su_i mentor visitó a cada chico_i (Spanish)
his mentor visit-PAST-3.SG to each boy
'His mentor visited each boy'

[from Ordóñez 2005: 45]

(177) *Variable binding (2)*

- a. Recogió cada coche_i su_i propietario. (Spanish)
pick-up-PAST-3.SG each car its owner
'Its owner picked each car up'
- b. No regañó a ningún niño_i su_i madre. (Spanish)
not scold-PAST-3.SG to no child his mother
'His mother did not scold any child'

[from Gallego 2005: 62]

(178) *Condition (C) effects*

- a. *Lo_i vieron (a él_i) los amigos de Pablo_i (Spanish)
CL-him see-PAST-3.PL to him the friends of Pablo
'Pablo's friends saw him'
- b. *Lo_i llamaron (a él_i) los hermanos de Juan_i (Spanish)
CL-him call-PAST-3.SG to him the brothers of Juan
'Juan's brothers called him'

that only *todos* can marginally allow binding in a non-distributive fashion; with *todo*, sentences are out:

- (i) ?Recogieron todos los coches_i sus_i propietarios. (Spanish)
pick-up-PAST-3.PL all the cars their owners
'Their owners picked up all the cars'
- (ii) *Recogió todo coche_i su_i propietario. (Spanish)
pick-up-PAST-3.SG all car its owner
'Its owner picked up all car'

There are many conspiring factors in these facts, one of them being agreement, as Ricardo Etxepare (p.c.) notes.

As in the case of Italian, Catalan does not allow for objects bind within subjects:⁹⁰

(179) *Variable binding*

- a. ??Ahir va visitar cada estudiant_i el seu_i professor. (Catalan)
 yesterday AUX-3.SG visit-INF each student the his teacher
 ‘His teacher visited each student’
- b. ??Va recollir cada cotxe_i el seu_i propietari. (Catalan)
 AUX-3.SG pick-up-INF each car the his owner
 ‘His owner picked up each car’
- c. ??No va renyar cap nen_i la seva_i mare. (Catalan)
 not AUX-3.SG scold-INF any child the his mother
 ‘His mother did not scold any child’

Given the discussion about Icelandic *Object Shift*, the question of whether objects in VOS sequences are interpreted as specific in Spanish is in order. Ordóñez (1998b: 332 ff.) argues they are, but I disagree.

What Ordóñez (1998b) does show is that shifted objects in Spanish have wide scope reading: thus, whereas according to Ordóñez (1998b) the indirect object DP *a un profesor* (Eng. *to a teacher*) is specific in (180b), I think it does not have to be.

(180)

- a. Estos libros, se los dieron todos . . .
 these books, SE-to-him CL-them give-PAST-3.PL all
 . . . los estudiantes a un profesor. (Spanish)
 the students to a teacher
 ‘These books, all the students gave them to a teacher’
- b. Estos libros, se los dieron . . .
 these books, SE-to-him CL-them give-PAST-3.PL
 . . . a un profesor todos los estudiantes. (Spanish)
 to a teacher all the students

⁹⁰ Catalan judgments are due to M. Teresa Espinal, Jaume Mateu, M. Carme Picallo, Gemma Rigau, and Jaume Solà. There is minor variation among speakers, judgments going from * to ? In any event, the thing is that there is a clear contrast with respect to Spanish.

‘These books, all the students gave to a teacher’

[from Ordóñez 1998b: 334]

Consider also (181), where I can hardly find interpretive differences. To my ear, the most remarkable trait of (181) is that when the object is shifted, a wide scope reading is preferred:

(181)

- a. Compraron un libro todos los estudiantes. *Narrow / Wide Scope* (Spanish)
buy-PAST-3.PL a book all the students
‘All the students bought a book’
- b. Compraron todos los estudiantes un libro. *Narrow / ?Wide Scope* (Spanish)
buy-PAST-3.PL all the students a book
‘All the students bought a book’

The question that arises next is where shifted objects move. Ordóñez (1998b) identifies this position as the specifier of a functional projection above the VP: SPEC-F. As indicated in (175b) above, I take Ordóñez’s (1998b) SPEC-F to be an outer-SPEC-*v**.

Taking stock: shifted objects can (but need not) be interpreted as specific DPs. This may be related to the fact that Spanish has alternative strategies to give rise to specificity. As Bosque (2001) argues, one such strategy is adjective placement: in (182b) the pronominal position of the adjective *famoso* (Eng. *famous*) forces a specific reading of the indefinite DP *un actor* (Eng. *an actor*).

(182)

- a. Las cinco muchachas habían conocido a un actor famoso. (Spanish)
the five girls have-PAST-3.PL met to an actor famous
‘The five girls had met a [specific/non-specific] famous actor’
- b. Las cinco muchachas habían conocido a un famoso actor. (Spanish)
the five girls have-PAST-3.PL met to a famous actor
‘The five girls had met a [specific] famous actor’

[from Bosque 2001: 2]

Apart from wide scope interpretations, we must consider whether shifted objects display any other semantic effect. According to Belletti (2004), they are interpreted as part of the presupposition: therefore, (183A) can only be answered with (183B), not (183B'), nor (183B'').

(183)

A: [Quién]_{FOCUS} [cogió los libros]_{PRESUPPOSITION?} (Spanish)

who take-PAST-3.SG the books

'Who took the books?'

B: [Cogió los libros]_{PRESUPPOSITION} [Juan]_{FOCUS} (Spanish)

take-PAST-3.SG the books Juan

'Juan took the books'

B': #[Cogió Juan]_{PRESUPPOSITION} [los libros]_{FOCUS} (Spanish)

take-PAST-3.SG Juan the books

'Juan took the books'

B'': #[Juan cogió]_{PRESUPPOSITION} [los libros]_{FOCUS} (Spanish)

Juan take-PAST-3.SG the books

'Juan took the books'

The facts in (176) through (178) lead to the hypothesis that Spanish *Object Shift* is a case of so-called A-movement, since the operation feeds binding. An important property of A-movement is that it fails to reconstruct (see Boeckx 2001 for ample discussion), but this is in conflict with (184):

(184) *Reconstruction of shifted object*

a. [_{C*P} Qué C* le regaló [_{TP} T_s [_{v*P} a su_i amigo [_{v*P} cada niño_i v* t_{a su amiga}]]]]? (Spanish)

what CL-to-him give-PAST-3.SG to his friend each boy

'What did each boy give to his friend?'

b. [_{C*P} C* [_{TP} Aquí T_s besó [_{v*P} a su_j amiga [_{v*P} cada niña_j v* t_{a su amiga}]]]]? (Spanish)

here kiss-PAST-3.SG to her friend each girl

'Each girl kissed her friend here'

[from Ordóñez 1998b: 324]

As we see, in (184), it seems as if the base copies of the DPs *a su amigo/a su amiga* (Eng. *his friend*) can be used by the quantified subjects for binding purposes. Ordoñez (1998b) notices, and compares (184) with examples such as the ones in (185), where reconstruction fails:

(185) *No reconstruction of shifted object*

a. [_{C*P} Este libro C* [_{TP} T_S se lo regaló [_{v*P} a cada_i niño [_{su_i} amigo v* t_{a cada niño}]]]]] (Spanish)
 this book CL-to-him CL-it give-PAST-3.SG to each boy his friend

‘This book, his friend gave to each boy’

b. *[[_{C*P} C* [_{TP} T_S LO_i vieron [_{v*P} a él_i [_{v*P} los amigos de Pablo_i v* t_{lo-a él}]]]]] (Spanish)
 CL-him see-PAST-3.PL (to him) the friends of Pablo

‘Pablo’s friends saw him’

Ordóñez (1998b: 327) concludes that the tension between (184) and (185) is solved if *variable binding* and *Condition (C)* are satisfied at different derivational stages. I will depart from this explanation, arguing: first, that *Object Shift* is *bona fide* A-movement, and, second, that the alleged reconstruction effects in (184) follows from covert internal Merge of the post-verbal quantified subjects. In particular, all we need in these examples is for the quantified subjects to undergo covert internal Merge (i.e., Quantifier Raising) to an outer-SPEC-*v** -from that position, they can c-command the shifted objects:⁹¹

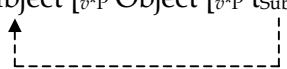
(186) [_{v*P} Subject [_{v*P} Object [_{v*P} t_{Subject} v* [_{VP} V t_{Object}]]]]

 covert internal Merge

⁹¹ The possibility I am appealing to builds on Uribe-Etxebarria’s (1992) idea that quantified post-verbal subjects, like the ones in (184), undergo covert QR. The same is shown in (ii), where the subject *cada senador* (Eng. *each senator*) can covertly move in order to yield a pair-list reading, unavailable in (i).

- (i) [_{C*P} A quién_z C* dices [_{C*P} C* que [_{TP} cada senador_i T_S amaba_j [_{v*P} t_i t_j t_z]]]? (Spanish)
 to who say-2.SG that each senator love-PAST-3.SG
 ‘Who do you say that each senator loved?’
- (ii) [_{C*P} A quién_z C* dices [_{C*P} que [_{TP} T_S amaba_i [_{v*P} cada senador t_i t_z]]]]? (Spanish)
 to who say-2.SG that love-PAST-3.SG each senator
 ‘Who do you say that each senator loved?’

So far I have been referring to the process involved in deriving Spanish VOS as *Object Shift*. But: is this type of *Object Shift* analogous to the one studied in Scandinavian languages? Let us consider now the properties of standard *Object Shift* more seriously, trying to see whether the similarities go beyond mere terminology.

The literature on *Object Shift* has regarded this operation as parasitic to *verb movement* and *phonological constraints* (see Bobaljik & Jonas 1996, Chomsky 1993a; 2001, Fox & Pesetsky 2005, and Holmberg 1986; 1999; 2005). Intriguingly enough, those phenomena are different in non-trivial respects.

The idea in that *Object Shift* necessarily invokes *v*-to-T* movement (an observation referred to as *Holmberg's Generalization*) was entertained within the framework outlined in Chomsky (1993a; 1995b), where verb movement can manipulate ('stretch') syntactic domains.

Take the configuration in (187): by IhM (X, Y), SPEC₁ and SPEC₂ were said to become equidistant:

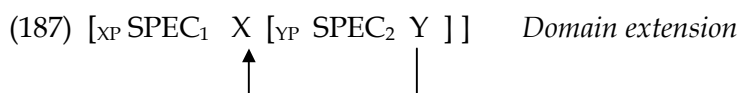

Paradigms like (188) supported this approach to *Object Shift*. As the data show, *Object Shift* is barred unless *v** moves to T_S. In the examples, I signal the verb with **grey background** and the shifted object with *bold letter* to highlight the most relevant factors.

(188)

a. [_{C*P} C [_{TP} Jag T_S **kysste**_{VERB} [_{v*P} **henne** [_{v*P} inte [t_{Jag} t_{kysste} t_{henne}]]]]]] (Swedish)

I kiss-PAST-1.SG her not

'I did not kissed her'

b. * [_{C*P} C [_{TP} Jag T_S har [_{v*P} **henne** [_{v*P} inte [t_{Jag} **kysste**_{VERB} t_{henne}]]]]]] (Swedish)

I have-1.SG her not kiss-PAST-1.SG

'I have not kissed her'

- c. ... * $[_{C^*P} C^* \text{ att } [_{TP} \text{ jag } T_S [_{v^*P} \text{ henne } [_{v^*P} \text{ inte } [_{v^*P} \text{ t}_{\text{jag}} \text{ kysste}_{\text{VERB}} \text{ t}_{\text{henne}}]]]]]]]$ (Swedish)
 ... that I her not kiss-PAST-1.SG
 ‘... that I did not kiss her’

[from Holmberg 1999: 1]

In these examples, the verb *kysste* (Eng. *kissed*) moves to T_S only in (188a). In the other examples, it remains *in situ* because either the complementizer or an auxiliary blocks its movement, rendering *Object Shift* illegitimate.

As for the second take on *Object Shift*, it appears to be motivated by the facts in (189), where material left stranded in v^*P 's edge block this process. Notice that it is not immediately obvious that (189) could be explained by invoking either the MLC or equidistance, for even particles block it. In this case, I underscore the alleged *phonological interveners* with grey background.

(189) *Phonological material blocks Object Shift*

- a. * $[_{C^*P} C^* [_{TP} \text{ Jag } T_S \text{ gav}_{\text{VERB}} [_{v^*P} \text{ den } [_{v^*P} \text{ inte } [_{v^*P} \text{ t}_{\text{Jag}} \text{ Elsa } \text{ t}_{\text{gav}} \text{ t}_{\text{den}}]]]]]]]$ (Swedish)
 I give-PAST-1.SG it not to-Elsa
 ‘I did not give it to Elsa’
- b. * $[_{C^*P} C^* [_{TP} \text{ Dom } T_S \text{ kastade}_{\text{VERB}} [_{v^*P} \text{ mej } [\text{ inte } [_{v^*P} \text{ t}_{\text{Dom}} \text{ t}_{\text{kastade}} \text{ ut}_{\text{PARTICLE}} \text{ t}_{\text{mej}}]]]]]]]$ (Swedish)
 they throw-PAST-3.PL me not out
 ‘They did not throw me out’

[from Holmberg 1999: 2]

Crucially, as Holmberg (1999) observes, if the offending material is removed, *Object Shift* is fine again:

(190) *IM of material in v^*P 's edge frees Object Shift*

- a. $[_{C^*P} C^* \text{ Kysst}_{\text{VERB}} \text{ har } [_{TP} \text{ jav } [_{v^*P} \text{ henne } [\text{ inte } [\text{ t}_{\text{jav}} \text{ t}_{\text{kisst}} \text{ t}_{\text{henne}}]]]]]]$ (Swedish)
 kissed have-1.SG I he not
 ‘Kiss, I did not did that to her’
- b. $[_{C^*P} \text{ Vem}_{\text{I-OBJ}} C^* \text{ gav}_{\text{VERB}} [_{TP} \text{ du } T_S [_{v^*P} \text{ den } [_{v^*P} \text{ inte } [_{v^*P} \text{ t}_{\text{du}} \text{ t}_{\text{VERB}} \text{ t}_{\text{vem}} \text{ t}_{\text{den}}]]]]]]$ (Swedish)
 who give-PAST-2.SG you it not
 ‘To whom didn’t you give it?’

actually on track. More to the point, I claim that NSLs differ with respect to what option they choose.

At the outset of section 5 it was noted that only the structure in (192b) is problematic for *Phase Theory*, as it conflicts with the MLC if equidistance is dispensed with: in order to assign nominative Case to the *in situ* subject, T_S 's ϕ -Probe must bypass the shifted object.

Technically, there is more than one solution for nominative Case to be successfully assigned to the subject in a configuration like (192b). Consider the following:

(193) *Strategies to assign nominative Case in VOS structures*

- a. Object and subject are equidistant (see Chomsky 1993a, 1995b, 2000)
- b. A 'richer' T_S can probe deeper, bypassing the object (see Chomsky 2001)
- c. Object is rendered opaque by v^* -to-T movement (see Chomsky 2004)
- d. Object is targeted by a phonological operation (see Chomsky 2001)
- e. ϕ -features do not trigger intervention (see Richards 2004)
- g. v^* assigns both nominative and accusative (see Sigurðsson 2003; 2006)
- h. NSLs lack nominative Case (see Rosselló 2000)

With Gallego (2005), Here I would like to argue that v^* -to-T movement (i.e., *Phase Sliding*) is the key.⁹² In Gallego (2005), I explored the possibility that v^* -to-T movement amalgamates T_O and T_S creating a 'combo-Probe,' which resulted in an extended domain where *nominative and accusative are assigned derivationally simultaneously*, as shown in (194b):

⁹² Noam Chomsky (p.c.) suggests that VOS structures may be generated by having both arguments in SPECs of T_S ; taking the ϕ -Probe to be on T_S , and assuming the MLC is calculated at the end of a phase, the intervention effect vanishes. However, this must assume that the verb has moved to C^* (by means of a V2-like operation) and, also, that objects can undergo A-movement to SPEC- T_S . At present I do not know how to motivate these steps in a non-stipulative way.

(194)

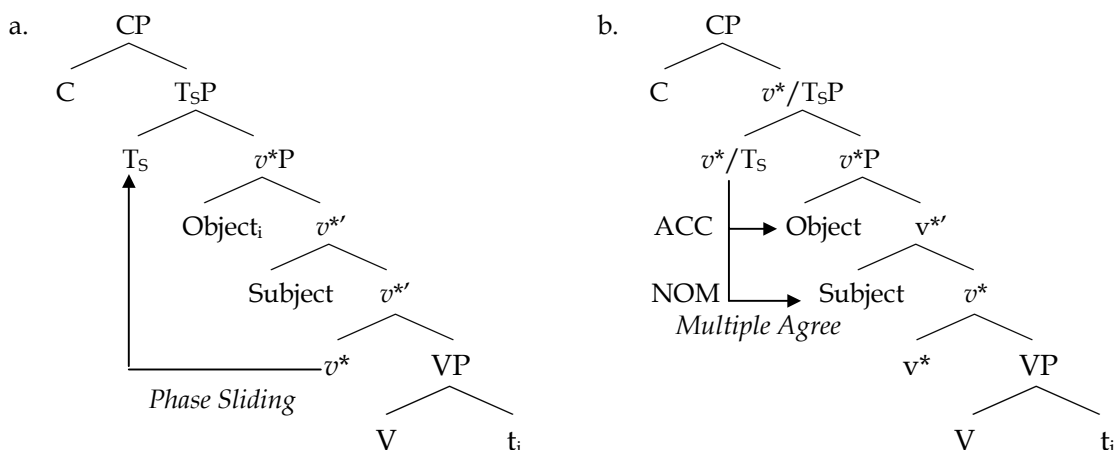

As (194) shows, Gallego (2005) assumes that *Phase Sliding* allows Spanish to instantiate a *complex* case of Multiple Agree: it not just a mere ‘one Probe – two Goals’ situation that we have in (194), but rather a ‘two Probes – two Goals’ situation.

Note, though, that the process has an undesired impact on the architecture of the system. Under normal circumstances, accusative Case is taken to be assigned in the v^*P phase, before the first application of Transfer: (194) challenges that scenario.

This observation, happily, does not mean that *Phase Sliding* cannot be the key for nominative assignment in VOS structures: it simply means that accusative and nominative cannot be assigned within the same phase. Although this goes against the logic of Gallego (2005), I take it to be a more natural route.

In order to account for nominative Case assignment in VOS, here I want to revamp Chomsky’s (1993a; 1995b) domain extension analysis, arguing that nominative can be assigned, bypassing the object, if v^* -to-T movement collapses those dependents –in other words, I am forced to assume a *restricted version of equidistance whereby certain domains are collapsed if head movement takes place*.

Importantly, notice that the shifted object poses no intervention problem for the T-Probe launched from T_s (because the T feature of the object has already been deleted in the v^*P phase): it is the ϕ -features of the object that do, for these remain active, due to its interpretable status.

I hasten to add that the reasoning, although not entirely appealing (because the very notion of *equidistance* is not appealing) makes sense: equidistance was dispensed with not only because it was at odds with the idea that intervention effects arise under “closest c-command” (the null hypothesis), but also because it was parasitic on head movement being syntactic (*contra* Chomsky 2001). If, as I have argued throughout, (some instances of) head movement are syntactic, then the arguments against equidistance lose part of its strength.

It is worth underscoring that a *Phase Sliding* analysis makes one obvious prediction: if the verb does not move, the phase does not slide, and, consequently, VOS should be out.⁹³ It is not easy to find contexts where one can control for verb movement. In principle, we need for some element to already occupy T_S, forcing the *v**-T_O-V complex to remain *in situ*. A good candidate to do that job is the auxiliary *estar* (Eng. *be*) in progressive sentences.⁹⁴ Consider the baseline (195), where *está* is in T_S, and –I assume– all the elements remain in their base positions: most crucially, the lexical verb *leyendo* (Eng. *reading*) is forced to remain in *v**.

(195) [_{C*P} C* [_{TP} Ayer T_S estaba [_{v*P} Juan *v** **leyendo** un libro]]] (Spanish)
 yesterday be-PAST-3.SG Juan reading a book
 ‘Juan was reading a book yesterday’

The relevant empirical test is now (196), where the object DP *un libro* (Eng. *a book*) is shifted over the subject. As expected, the result is ungrammatical.

(196) * [_{C*P} C* [_{TP} Ayer T_S estaba [_{v*P} *un libro* [_{v*P} Juan *v** **leyendo** t_{un libro}]]]] (Spanish)
 yesterday be-PAST-3.SG a book Juan reading
 ‘Yesterday, Juan was reading a book’

⁹³ For technical help in discussing these facts, I would like to thank Masaya Yoshida, Iván Ortega-Santos, and, very especially, Tomohiro Fujii.

⁹⁴ Due to reasons that I do not understand, *estar* (Eng. *be*_{STAGE LEVEL}) is the best auxiliary verb in getting the order AUX-S-V-O in Spanish (or, at least, it is the better one to my ear; I think that *Debería Juan leer los libros* –Should Juan read the books– is also good, but I have not tested the different possibilities systematically).

I am sure, nevertheless, that *ser* (Eng. *be*_{INDIVIDUAL LEVEL}), *haber* (Eng. *have*) and modals like *poder* (Eng. *can/may*) or *deber* (Eng. *must*) do not successfully allow such pattern, which is a necessary condition to test the movement of the object.

I take (196) to be evidence in favor of an *Object Shift* account in terms of Holmberg's *Generalization*, and not phonological factors, at least in the case of Spanish. In fact, the minute we move the verb, *Object Shift* is fine again, as (197) indicates:⁹⁵

- (197) [_{C*P} [_{TP} Ayer T_S estaba [_{XP} leyendo_{VERB} [*un libro* [Juan v* t_{leyendo} t_{un libro}]]]]] (Spanish)
 yesterday be-PAST-3.SG reading a book Juan
 'Yesterday, Juan was reading a book'

In addition to (197), there are other 'repair strategies' for failed *Object Shift*. We can, for instance, move either the verb or the shifted object to the *Left Periphery*. According to my analysis, that would remove the intervention effect. Let us test this, taking (198) as the baseline:

- (198) * [_{C*P} C* [_{TP} Estaba [_{v*P} a cada niño [_{v*P} su madre v* vistiendo t_{a cada niño}]]]] (Spanish)
 be-PAST-3.SG to each child his mother dressing-up
 'His mother was dressing each child'

Now: see how the aforementioned strategies do repair (198):⁹⁶

- (199) 1st Repair strategy: object movement to SPEC-C*

[_{C*P} A CADA NIÑO C* estaba [_{TP} T_S [_{v*P} t_{a cada niño} [_{v*P} su madre v* vistiendo t_{a cada niño}]]]]

- (200) 2nd Repair strategy: verb focalization

[_{C*P} VISTIENDO_{VERB} C* estaba [_{TP} T_S [_{v*P} a cada niño [_{v*P} su madre v* t_{vistiendo} t_{a cada niño}]]]]

⁹⁵ Here I do not address the question of where the verb moves in (197).

⁹⁶ Luis Vicente informs me (p.c.) that the datum in (200) appears to assume excorporation. That is, I think, correct. Actually, notice that various instances of T-to-C movement, as understood by Pesetsky & Torrego (2001), involve excorporation too. Think, say, of my analysis of *que* (Eng. *that*) as being the spell-out of T_S moved to C*: there, too, T_S appears to excorporate from the v*-V-T_O complex. For additional discussion about excorporation, see Roberts (1994; 2006). Since this technical issue is not crucial for the discussion here, I put it aside.

The datum in (201), where it is shown how datives (the PP *a los niños* –Eng. *to the children*) do not block *Object Shift*, also reinforces the adopted analysis: *v*-to-T* movement is all that matters when it comes to *Object Shift* in Spanish.

(201) [_{C*P}[_{TP} T_S Estaba **dándoles**_{VERB} [_{v*P} *los regalos* [María [a los niños t_{dándoles} t_{los regalos}]]]]]
be-PAST-3.SG giving-CL-to-them the presents María to the children
‘María was giving the children the presents’

Let us recap. In this section I have explored how VOS sequences are derived in NSLs. It has been argued that, in the case of Spanish (and also Galician, E.Portuguese, and Romanian, but not in Catalan and Italian) VOS obtains by moving the object to a position that c-commands the subject.⁹⁷

A particularly noteworthy consequence emerges in the context of *Phase Theory*, where the shifted object should block Agree (T_S, Subject), contrary to fact. How can the tension be solved? Chomsky (2004) makes a cryptic suggestion to avoid derivational crash of VOS structures that is compatible with what I am proposing:

We might ask whether in such cases [Obj remaining in SPEC-*v**] *v** has raised to T, so that the Spec position does not interfere between T and EA.
[from Chomsky 2004: 128]

How must we understand “does not interfere between T and EA”? Intuitively, it is as if *EA and shifted object were collapsed by v*-to-T*, and that, as I understand it, requires equidistance, as said above. Perhaps Gallego’s (2005) solution of assigning nominative and accusative within the same cycle is more appealing in that it dispenses with equidistance, but it must crucially assume that accusative Case is not assigned within the first phase, a problematic move for the architecture of Chomsky’s system, for it virtually neglects the rationale for having cycles.

In the next section I focus on VSO structures, but before going into that, I would like to briefly consider Richards’ (2004) thesis that there are no defective intervention effects.

⁹⁷ See Cardinaletti (2001b) and Costa (2000; 2002) for the same analysis in Italian and E.Portuguese.

Richards (2004: 161) argues that the idea that inactive DPs create intervention effects is an unpleasant and unnecessary complication of the theory: “ideally, a DP should either be a potential goal or it should not, and inactive nominals should be just that: inactive, for goalhood and intervention alike.”⁹⁸ As Richards (2004) observes, there are three types of evidence in favor of defective intervention effects:

(202) DEFECTIVE INTERVENTION EFFECTS

- a) quirky subjects
- b) expletives
- c) *wh- Object Shift*

Richards (2004) discusses these cases, noting that they force Chomsky (2000; 2001) to make non-obvious assumptions, like the idea that the intervention effect created by quirky subjects and expletives (see Boeckx 2000a; 2006b) only follows if expletives have [person] and quirky subjects bear “inherent Case with an additional structural Case” (see Chomsky 2000: 127; 2001: 43 fn. 8).

As for (202c), Richards (2004) notes that Chomsky’s (2001) analysis of nominative Case assignment across *wh*-objects goes through under two odd assumptions as well: first, traces must be regarded as invisible to Match and, second, evaluation of operations takes place at the phase level.

Richards (2004) discards (202c) entirely and proposes a unified analysis for (202a) and (202b) whereby quirky subjects are as depicted in (203): that is, as DPs with an additional layer hosting an expletive with the minimal ϕ -specification, a [person] feature.

(203) quirky subject = inherent Case + expletive

(203) allows an otherwise unnatural conception of quirky subjects and expletives as a natural class for the purposes of Agree.

⁹⁸ See Broeckhuis (2007) for the same claim.

Viewed that way, partial agreement displayed with quirky subjects follows from T_S agreeing first with the expletive shell in [person], and then with the downstairs DP (the would-be associate) in [number]. As Richards (2004) argues, there is no intervention, but rather ‘split agreement.’ Accordingly, the fact that the nominative object cannot be 2nd/1st person (see 204 below) follows from the nondistinctness condition on Match/Agree: “an object with a lexical value or 1-/2-person is distinct from the T-probe’s 3-person, and therefore fails to be matched by T. Since Agree (T, Object) thus fails, Case on the object remains unvalued, yielding nonconvergence at LF –a Case effect.” (from Richards 2004: 167)

(204)

- a. Henni leiddust Peir (Icelandic)
her-DAT bore-PAST-3.PL they-NOM
‘They bored her’
- b. *Henni leiddumst við (Icelandic)
her-DAT bore-PAST-1.PL we-NOM
‘We bored her’

Let us now go back to *Object Shift*. If there are no defective intervention effects, as Richards (2004) contends, what would rule (196) out, repeated here as (205)?

- (205) * $[_{C^*P} C^* [_{TP} \text{Ayer } T_S \text{ estaba } [_{v^*P} \text{un libro } [_{v^*P} \text{Juan } v^* \text{leyendo } t_{un libro}]]]]$ (Spanish)
yesterday be-PAST-3.SG a book Juan reading
‘Yesterday, Juan was reading a book’

As Marc Richards observes through personal communication, (205) would be out due to the fact that the object moves across the verb, Spanish being a VO language.

If I interpret him correctly, Richards is saying that a linearization parameter is responsible for (205)’s deviance, which I do not agree with. To see this, consider the sentence in (206), which is possible in my Spanish idiolect. I would like to take this example as direct evidence that (205) is out not because of the *Object Shift per se*.⁹⁹

⁹⁹ The odd status of (206) certainly follows from having moved the object to a SPEC of a non-finite form, which, as I have argued in this chapter, does not normally allow syntactic objects to

- (206) ?/??[_{C*P} C* [TP T_S Estaba [_{v*P} **los libros** [_{v*P} *pro* v* leyendo t_{los libros}]]]] . . .
 be-PAST-3.SG the books pro reading
 ... cuando, de pronto, llegó María. (Spanish)
 when, of soon, arrive-PAST-3.SG María
 ‘He was reading the books... when, suddently, María showed up’

To some speakers (206) may not sound entirely natural (it has a somewhat rethorical style, whence the question marks), but *it is not out*. The important example is (207), virtually identical to (206), which is fully out if compared to it –crucially, even those speakers who are reluctant to accept (206) see the contrast between (206) and (207), the latter being much worse. The point here is that the judgements are comparative, rather than absolute.¹⁰⁰

- (207) *[_{C*P} C* [TP T_S Estaba [_{v*P} **los libros** [_{v*P} Juan v* leyendo t_{los libros}]]]] . . .
 be-PAST-3.SG the books Juan reading
 ... cuando, de pronto, llegó María. (Spanish)
 when, of soon, arrive-PAST-3.SG María
 ‘Juan was reading the books... when, suddently, María showed up’

I would like to claim that the contrast has to do, precisely, with defective intervention: in (207) *Juan* cannot check its Case feature because *los libros* (Eng. *the*

stay in their SPECS, due to morphological reasons. As expected from all I have said, the Catalan counterpart of (205) is not merely deviant: it is completely out.

¹⁰⁰ An example that supports the possibility to generate sentences like (206) is taken from lyrics from the Spanish group *El último de la fila*.

Consider (i), which has the narrative style I mentioned, but is perfectly fine. I signal the relevant chunk in bold letters.

- (i) Vestido de hombre rana, un domingo te vendré a buscar... ♪ ♪
 dressed of man frog a Sunday CL-you come-FUT-1.SG to look-for-INF
 ... como van **todos los novios a sus novias** a buscar. ♪ ♪
 like go-3.PL all the boys to their girlfriends to look-for-INF
 ‘Dressed like a frogman, I will come for you a given Sunday...
 ... like every boy comes for his girlfriend, I will come for you’

In abstract terms, the structure is as in (ii), where I assume the object *a sus novias* (Eng. *to their girlfriends*) has been shifted from its base position.

- (ii) AUX Subject Object INFINITIVE

Crucially, the reverse order (something like iii) is clearly much worse than (i) to my ear:

- (iii) ... como van **a sus novias todos los novios** a buscar. ♪ ♪
 like go-3.PL to their girlfriends all the boys to look-for-INF
 ‘... like everboy comes for his girlfriend, I will come for you’

books) intervenes. In contrast, (206) is fine because there is no intervention, as in (206), the subject (a little *pro*, I assume) has moved to SPEC-T_S: since it is not c-commanded by *los libros*, Case assignment to *pro* succeeds. Hence, I modify (206) as follows, where *pro* occupies SPEC-T_S:

- (208) $[/\?/?/[_{C^*P} C^* [_{TP} pro T_S Estaba [_{v^*P} los\ libros [_{v^*P} t_{pro} v^* leyendo t_{los\ libros}]]]]] \dots$
 pro be-PAST-3.SG the books reading
 ... cuando, de pronto, llegó María. (Spanish)
 when, of soon, arrive-PAST-3.SG María
 ‘He was reading the books... when, suddently, María showed up’

Cedric Boeckx and Noam Chomsky ask whether the same holds with overt subjects. As (209) shows, the answer is yes.

- (209) $[_{C^*P} C^* [_{TP} (?/??)Juan) T_S estaba [_{v^*P} los\ libros [_{v^*P} (*)Juan) v^* leyendo t_{los\ libros}]]]] \dots$
 Juan be-PAST-3.SG the books Juan reading
 ... cuando, de pronto, llegó María. (Spanish)
 when, of soon, arrive-PAST-3.SG María
 ‘He was reading the books... when, suddently, María showed up’

Note that this analysis takes us back to a particularly controversial point: does the EPP₂ hold in NSLs? I will address this question in section 6 below.

5.2. A Multiple Agree Analysis for VOS?

Last section was dedicated to explore the derivation of VOS structures in NSLs, concluding that Catalan and Italian differ from languages like Spanish, E. Portuguese, and Galician in resorting to a VP topicalization strategy. Examples like (210), provided by Belletti (2004), were taken as evidence to show that Italian VOS objects do not c-command their subjects.

(210)

A: Chi ha salutato Gianni? (Italian)
who have-3.SG greeted Gianni
'Who greeted Gianni?'

B: *Hanno salutato Gianni_i i propri_i genitori. (Italian)
have-3.PL greeted Gianni the own parents
'His own parents have greeted Gianni'

[from Belletti 2004: 36]

Some data due to Anna Cardinaletti (see Cardinaletti 2001b), though, cast doubt on such a clear cut asymmetry between Italian and Spanish.

(211)

a. Ha visitato ogni ragazzo_i sua_i madre. (Italian)
have-3.SG visited every boy his mother
'His mother has visited every boy'

b. Ha visitato Gianni un collega della propria moglie. (Italian)
have-3.SG visited Gianni a colleague of-the own wife
'Gianni has visited a colleague of his own wife'

[from Cardinaletti 2001b: 129]

Belletti (2004) agrees that the judgment of (211b) is better than (210B), for reasons that appear to depend on embedding of the anaphoric possessive *proprio* (Eng. *own*). Significantly, Belletti (2004) argues that when subject and object are clearly differentiated by means of agreement, ungrammaticality shows up again:

(212)

a. *Hanno salutato Gianni i genitori della propria moglie. (Italian)
have-3.PL greeted Gianni the parents of-the own wife
'The parents of his own wife have greeted Gianni'

b. *Hanno salutato ogni ragazzo i sui genitori. (Italian)
have-3.PL greeted every boy the own parents
'His own parents have greeted every boy'

[from Belletti 2004: 48]

Anna Cardinaletti, through personal communication, notes that the sentences in (212) are marked, but not ungrammatical. According to her, (213), which essentially displays the same agreement pattern, is only mildly degraded:

(213) ?Hanno salutato Gianni i suoi genitori. (Italian)
 have-3.PL greeted Gianni the his parents
 ‘His parents have greeted Gianni’

As for Spanish, things are also murky. Consider the data in (214), which do not behave uniformly: to my ear, plural agreement across singular object is worse if binding is forced by a quantified object DP.¹⁰¹

(214)
 a. Llamó a todos los niños_i su_i maestro. (Spanish)
 call-PAST-3.SG to all the kids his master
 ‘His master called all the kids’

b. ?/??Llamaron a cada niño_i sus_i profesores. (Spanish)
 call-PAST-3.PL to every kid his teachers
 ‘His teachers called every kid’

Put together, these facts might be taken to suggest that, when raised to an outer-SPEC-*v**, objects interfere with nominative Case assignment unless they bear the same \varnothing -specification. Technically, as Noam Chomsky observes through personal communication, that suggests a Multiple Agree account: T_S ’s \varnothing -Probe would match both the object and the subject derivationally simultaneously, as indicated in (215).

(215) [_{C*P} C* [_{TP} T_{S[\varnothing]} [_{v*P} Object_[\varnothing] [_{v*P} Subject_[\varnothing] [_{v*'} v* [_{VP} V t_{Object}]]]]]]



¹⁰¹ That is to say, when binding is not forced (because the object DP is not quantified), plural verb-subject agreement across a singular object is perfect:

(i) Cogieron el libro los niños. (Spanish)
 take-PAST-3.PL the book the kids
 ‘The kids took the book’

An analysis along the lines of (215) would also solve the intervention effect noted in chapter 3 –crucially, without invoking devices such as equidistance. However, it is rather unlikely that VOS structures require Multiple Agree: that would predict complete deviance, not a marked status for sentences like (214b).

As Cedric Boeckx notes, this effect resembles, *mutatis mutandis*, the facts observed by Anagnostopoulou (2003): according to her, there is a *weak version* of the *Person Case Constraint* (see chapter 1) found in so-called ‘inverse’ or ‘hierarchical’ systems, in which a) argument features receive a relative ranking (namely, *1st person > 2nd person > 3rd person*) and b) object [person]’s specification must not outrank subject’s. Obviously, the facts in (212) and (214) do not involve a [person], but a [number] hierarchy. Descriptively speaking, it seems that the following correlation is the relevant one:

(216) If binding is forced, and object is [singular], plural subject-verb agreement yields deviance

In other words, the ranking we need is *singular > plural*, as shown in (217):

(217)

- a. ?/?? V_{PL} – Object_{SG} – Subject_{PL}
- b. V_{SG} – Object_{PL} – Subject_{SG}

I therefore conclude that the effect in (214) (and that of 212) is an instantiation of a restriction similar to the one noted by Anagnostopoulou (2003), and not a *bona fide* intervention effect –which is what a Multiple Agree based account would predict.

5.3. VSO in NSLs

Let me start this section by quoting Bobaljik & Jonas (1996):

As an obvious consequence, this system entails that *raising of the object to SPEC-Agr_O is dependent upon verb raising (and adjunction) to Agr_O [...] If a language has overt OS, then it licenses SPEC-T as a (potential) A-position at S-Structure.*

[from Bobaljik & Jonas 1996: 201-203 –emphasis added, AJG]

Capitalizing on Bobaljik & Jonas’s (1996) words, I assume (218):

(218) OBJECT SHIFT COROLLARY

If a language L has *Object Shift*, then it licenses SPEC-T_S as a subject position

(218) must be qualified. Before going on, I would like to recall that by the time Bobaljik & Jonas (1996) wrote their paper, there were only two subject positions: the base one (SPEC-V or SPEC-*v**) and the derived one (SPEC-Agr_S). Thus, SPEC-T_S actually counted as a *third subject position*.¹⁰² Obviously, the point of Bobaljik & Jonas’s (1996) work was that while Icelandic licensed this third position, English did not. This is what must be kept in mind.

In section 5.1., I was interested in running the test of whether VOS involves *Object Shift*, and if so, how similar it was to the type of *Object Shift* we find in Icelandic. Empirical evidence showed that Spanish patterns with Icelandic more than it would appear at first glance.

In this section I want to pursue the intuition that, first, at the relevant level, VOS in Spanish involves what I would like to call *Residual Object Shift*, in honor of Rizzi’s seminal work on inversion (see Rizzi 1996), and, second, that having VOS through *Object Shift* licenses a third subject position, a subject position that is available in Spanish, but not in Catalan, as argued by Ordóñez (2005). Let us see whether all the pieces I have chosen match. To begin with, consider the paradigm in (170) again, repeated here as (209):

(219)

- | | | | |
|-----------------------------------|---------------|----------|---------------|
| a. En Joan fullejava | el diari. | SVO | (Catalan) |
| the Joan browse-PAST-3.SG | the newspaper | | |
| ‘Joan was browsing the newspaper’ | | | |
| b. Fullejava | el diari | en Joan. | VOS (Catalan) |
| browse-PAST-3.SG | the newspaper | the Joan | |
| ‘Joan was browsing the newspaper’ | | | |

¹⁰² See Cardinaletti (1997; 1999; 2004) for much relevant discussion about subject positions.

- c. *Fullejava en Joan el diari. VSO (Catalan)
browse-PAST-3.SG the Joan the newspaper
'Joan was browsing the newspaper'

[from Picallo 1998: 228-229]

Pay attention to (219c): *VSO order is out in Catalan*. Belletti (2004) points out that the same scenario is found in Italian.

(220)

- a. *Ha comprato Maria il giornale. (Italian)
have-3.SG bought Maria the newspaper
'Maria has bought the newspaper'
- b. *Ha colpito il bandito il carabiniere. (Italian)
have-3.SG hit the gangster the policeman
'The gangster has hit the policeman'
- c. *Ha incontrato il direttore del giornale il presidente. (Italian)
have-3.SG found the director of-the newspaper the president
'The director of the newspaper has found the president'

[from Belletti 2004: 26]

Belletti (2004) observes a further intriguing asymmetry: while VSO is out, VSPP is acceptable.

(221)

- a. (?)Ha telefonato Maria al giornale. (Italian)
have-3.SG phoned Maria to-the newspaper
'Maria has phoned the newspaper'
- b. (?)Ha parlato uno studente col direttore. (Italian)
have-3.SG spoken a student with-the principal
'A student has talked to the principal'
- c. (?)Ha sparato il bandito al carabiniere. (Italian)
have-3.SG shot the gangster to-the policeman
'The gangster has shot the policeman'

[from Belletti 2004: 26]

Belletti (2004) argues that the contrast between (220) and (221) is due to the MLC: assuming that the head assigning accusative Case is above the FocP to which post-verbal subjects move, Belletti (2004) proposes that subject blocks Agree (H, Object), where “H” stands for the relevant head assigning accusative Case. Since, on the other hand, PPs do not require movement to a Case checking position, the status of the data in (221) falls into place.

(222) [H [_{FocP} Subject Foc [_{TopP} Top [_{v*P} t_{Subject} v* Object]]]]

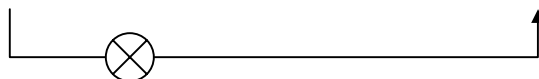

[adapted from Belletti 2004: 27]

Belletti (2004) realizes that VSO is okay in Spanish and Romanian (as well as E. Portuguese and Galician, to my knowledge):

(223)

a. Todos los días compra Juan el diario. (Spanish)

all the days buy-3.SG Juan the newspaper

‘Juan buys the newspaper everyday’

b. O invita cam de Ion pe fata acesta. (Romanian)

CL-her invite-3.SG quite often Ion pe girl the-that

‘Ion invites that girl quite often’

[from Belletti 2004: 33]

In order to account for (223), Belletti (2004) considers two routes: either Spanish allows an additional subject position or else it gets a further way to assign Case to the object, bypassing the subject. Belletti (2004) defends the latter view, noting that:

There appears to be a correlation between the availability of VSO and existence of a special Case marking of direct objects in the same set of languages involving a preposition under certain conditions [...] The preposition is also visible in object clitic doubling constructions also possible in both Spanish and Romanian [...] [T]he correlation [...] [A]ppears to hold beyond the Romance domain as it is also found in other languages as well, such as modern Greek.

[from Belletti 2004: 34]

Crucial for Belletti's (2004) account is the idea that the projection assigning accusative Case is outside the v^*P and that the object must move to it in order to get its Case feature checked. Though plausible, the analysis is clearly problematic: why does Case assignment require internal Merge if long-distance Agree can be invoked? And, why is the accusative Case assigning head outside the v^*P ? Since this approach departs in non-trivial respects from the system I have assumed so far, I cannot accept it (at least not in its technical part). However, I think we can keep the insight of Belletti's (2004) analysis while avoiding these shortcomings.

I agree with Belletti (2004) that there is a connection between having a special device to assign accusative (the Case marker *a* in Spanish; see Torrego 1995a; 1998a) and VSO, but I do not pursue the hypothesis that Spanish has a special way to assign accusative Case. Instead, I want to relate the possibility of having *a* with having a 'richer' v^* , one creating additional subject positions. Moreover, I want to suggest that there is a connection between $(C^*-)T_S$ and v^* in terms of 'morphological richness': if a language L has more left-peripheral fronting to C^*-T_S (like E.Portuguese, Galician, and Spanish; see section 2 above), it has more left-peripheral fronting to v^* too.

Ordóñez (2005) explores VSO order in Spanish and Catalan, adopting the option dismissed by Belletti (2004), namely, the hypothesis that Spanish (but not Catalan) provides itself with an additional (third) subject position. Building on different pieces of evidence, Ordóñez (2005) argues that Spanish is systematically provided with an extra subject position, one which seems to be barred in Catalan: normal VSO transitive sentences, small clauses selected by raising verbs, structures involving modals, and infinitival contexts illustrate this asymmetry:

(224) *Spanish vs. Catalan: transitive VSO sentences*

- | | | |
|----|--|-----------|
| a. | Hoy comprarà (Juan) comida (Juan). | (Spanish) |
| | today buy-FUT-3.SG Juan food Juan | |
| | 'Juan will buy food today' | |
| b. | Avui comprarà (*? en Joan) menjar (en Joan). | (Catalan) |
| | today buy-FUT-3.SG the Joan food the Joan | |
| | 'Joan will buy food today' | |

[from Ordóñez 2005: 4-8]

(225) *Spanish vs. Catalan: small clauses selected by “resultar” (Eng. turn out)*

- a. En Irak resultaron (varias personas) heridas (varias personas). (Spanish)
in Irak turn-out-PAST-3.PL several people hurt several people
'Several people ended up being hurt in Irak'
- b. Avui van resultar (*?molts soldats) ferits (molts soldats). (Catalan)
Today AUX-3.PL turn-out-INF many soldiers hurt many soldiers
'many soldiers ended up being hurt today'

[from Ordóñez 2005: 23]

(226) *Spanish vs. Catalan: modals*

- a. Por fin puede (Juan) dormir (Juan). (Spanish)
at last can-3.SG Juan sleep-INF Juan
'Juan can finally sleep'
- b. Finalment pot (*?en Joan) dormir (en Joan). (Catalan)
finally can-3.SG the Joan sleep-INF the Joan
'Juan can finally sleep'

[from Ordóñez 2005: 4-8]

(227) *Spanish vs. Catalan: infinitivals*

- a. Antes de comprar (Luis) manzanas (Luis). (Spanish)
before of buy-INF Luis apples Luis
'Before Luis buying the apples'
- b. Abans de comprar (*en Lluís) pomes (en Lluís). (Catalan)
before of buy-INF the Lluís apples the Lluís
'Before Lluís buying the apples'

[from Ordóñez 2005: 23]

According to Ordóñez (2005), Spanish has two subject positions for post-verbal subjects, and only one of them is available in Catalan. Ordóñez (2005) relates this third subject position to Bobaljik & Jonas's (1996) discussion about Icelandic, but, crucially, he does not relate the third subject position to having VOS through *Object Shift*.

Building on Ordóñez (2005), I want to connect those facts, and, more particularly, the double strategy to generate VOS (i.e., Belletti 2004 vs. Ordóñez 1998b analyses), to VSO.

In a nutshell: I claim that *if a language L can resort to an Object Shift-based derivation for VOS, it licenses the position necessary to generate VSO*. I also claim that the key has to do with v^* , which is a locus of parametric variation, as work by Esther Torrego has always suggested (see Torrego 1995a; 1995b; 1998a; 1998b). Suppose we formalize this hypothesis as (219):

(228) **VOS - VSO GENERALIZATION**

If L generates VOS through *Object Shift*, then it licenses VSO

Consider the subject positions available in Spanish and mentioned by Ordóñez (2005). They are as depicted in (229), where I put technical subtleties to the side:

(229) *Subject positions (non-final version) in Ordóñez (2005)*

- | | | | | | | | | | | | | | | | |
|----|---|---------|------------------|---|---------|----------------|---|---------|-------|---|----------------------|---|-----|-----|-----|
| a. | [| Subject | Agr _S | [| | T _S | [| | Focus | [| t _{Subject} | V | ... |]]] | SVO |
| b. | [| | Agr _S | [| Subject | T _S | [| | Focus | [| t _{Subject} | V | ... |]]] | VSO |
| c. | [| | Agr _S | [| | T _S | [| Subject | Focus | [| t _{Subject} | V | ... |]]] | VOS |

According to (229), Spanish lacks *in situ* subjects: in all the proposed structures, subjects escape the v^*P .

A problematic aspect of (229) is the presence of an Agr_SP projection, which is no longer a possibility within the current system. Actually, the streamlined v^*P structure, as standardly assumed in minimalism, leaves no room for a third subject position either.¹⁰³

There is, though, one possibility left, but for it to be entertained, one must go back to the v^*P structure I suggested in (148), repeated now as (230):

¹⁰³ Of course, it is not possible for this third position to be an outer-SPEC- v^*P : that would require v^* to probe into its own specifiers, a barred move (see Chomsky 2007; to appear)

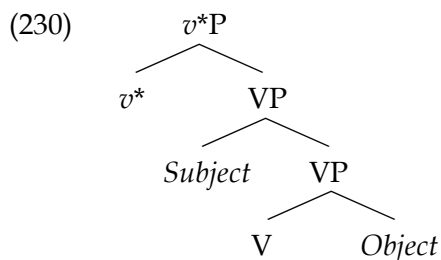

If EAs are generated in SPEC-V, we can recruit the three positions identified by Ordóñez (2005) as follows:

(231) *Subject positions (non-final version)*

- a. [Subject T_S [v* [V ...]]] SVO
 b. [T_S [Subject v* [V ...]]] VSO
 c. [T_S [v* [Subject V ...]]] VOS

The most dramatic change between (229) and (231) has to do with the possibility for subjects to remain *in situ*, and, also, with VSO sequences having their subject in what is normally understood to be the ‘base position:’ SPEC-*v**.

There is a most pressing problem with (230): how is nominative Case assigned in VOS? If the subject remains in the base position (here, SPEC-V), then it is impossible for T_S to probe it, because of the PIC. A solution is available if EA is always ‘externalized’ (see Alexiadou & Anagnostopoulou 2001; 2007, Chomsky to appear, Mayr 2007, and Moro 2006), having to vacate the VP.

Chomsky (to appear) argues that the EA (or, alternatively, the VP) must move because {XP, YP} structures are unstable, since no label can be provided.¹⁰⁴ Gallego (2007b), following an original suggestion of Cedric Boeckx (noted by Masaya Yoshida), tries to recast Chomsky’s (to appear) speculation by arguing that {X, Y} and {XP, YP} structures involve structural ambiguity.

¹⁰⁴ To be specific, Chomsky (p.c.) notes that minimal search cannot decide the label in these cases:

In [{XP, YP}], minimal search gives ambiguously either head of XP or head of YP (or worse, gives the one we don’t want, which can easily happen). The ambiguity of minimal search can be overcome if one or the other is extracted, and a natural convention is added, introducing an asymmetry: the non-copy has priority for further search.

Consider the details of this by looking at (232), where *see* and *Mary* undergo external Merge. In cases like this, Chomsky (2007; to appear) argues that the label is decided by “minimal search,” in accord with the algorithm in (233):¹⁰⁵

(232) EM (*see*, *Mary*) = {*see*, {*see*, *Mary*}}

(233) In {H, α }, H an LI, H is the label

[from Chomsky to appear: 11]

Gallego (2007b) observes (and so do Boeckx 2006a and Irurtzun 2007) that labeling in (232) looks as if *see* was remerged with {*see*, *Mary*}. Suppose we accept that. Consider next a more interesting case, like (234), where a complex DP (e.g., *the boy*) tries to merge with the VP {*see*, {*see*, *Mary*}}:

(234) {*the*, {*the*, *boy*}} → ← {*see*, {*see*, *Mary*}}

What is the outcoming label in (234)? If labeling does reduce to head movement, then the system cannot invoke minimal search: in (234) there are four possible candidates to do that job, namely, *the*, *boy*, *see*, and *Mary*.

The configuration we are considering immediately resembles cases for which, as far as I know, many technical problems have been noticed (extraction, linearization, adjunct connectivity, anti-locality, etc.). Typically, they all involve a *complex specifier* (see Uriagereka 1999a). I want to reinterpret the labeling problem in (234) in the terms suggested by Cedric Boeckx: if no label obtains whenever XP and YP undergo external Merge, then the system cannot decide whether XP is a(n outer) specifier of Y or vice-versa. In other words, no dependency can be formally established between XP and YP, as no context has been defined for them. This is shown in (235):

¹⁰⁵ Notice that, for (233) to apply as desired, it must be assumed that the DP *Mary* counts as an XP, hence qualifying as ‘complex.’

(235)

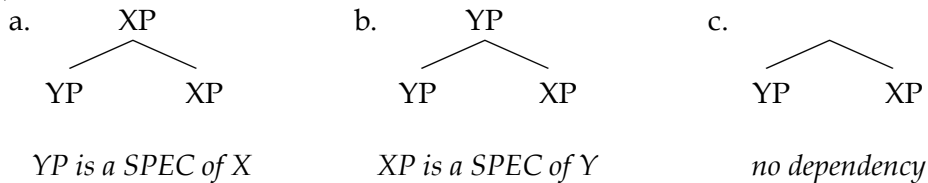

Let us suppose that, for this reason, EAs are always forced to escape from the VP.¹⁰⁶ Going back to our discussion here, this amounts to there being just two legitimate subject positions for Romance languages, and not three: SPEC-*v** (for *all kinds* of post-verbal subjects) and SPEC-T (for preverbal subjects). If this is on the right track, (231) must be qualified as follows:

(236) *Subject positions (final version)*

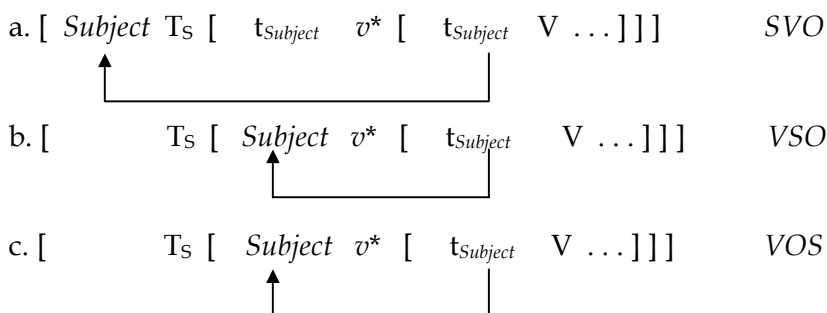

The scenario in (236) solves the Case problem we noted: in both (236b) and (236c), the subject can receive nominative Case, since it is within *v**'s edge.

(236) brings more consequences: in its most straight form, it entails the position occupied by subjects in VSO and VOS structures is one and the same, which is not immediately obvious, for it would predict that VSO in Catalan is possible, just like VOS is, contrary to fact.

The puzzle can be tackled if our analysis capitalizes on *the nature of functional heads, and not on having dedicated positions*. Thus, I want to argue that the relevant factor has to do with *v**, which can license dependents *qua* SPECs in Spanish, whereas only marginally so in Catalan and Italian –actually, in Catalan and Italian, *v** can only host

¹⁰⁶ Once in its derived position, the subject does not give rise any unstable (ambiguous) configuration. This is so because, by assumption, it is moved to a SPEC position of a higher Probe (be it *v**, T_S, or C*), hence it involves a *stable* {X, YP} pattern.

the subject DP when the VP is also moved (and only if the appropriate discourse factors are met, as Belletti 2004 notes). I conclude this is a plausible account of the asymmetries between Catalan and Spanish.¹⁰⁷

This section can be regarded as a follow-up of 5.1. I have tried to relate the availability of VSO in Spanish with the fact that this language can generate VOS via *Object Shift*. Following Ordóñez (2005) I have assumed that, in VSO, subjects are not *in situ*: they have moved to a position lower than T_SP. What is that position? For Ordóñez (2005), it is SPEC-T_S. I have argued that it is SPEC-*v**, instead. If so, *it appears that both shifted objects and subjects in this third position are dependents of the same head: the phase head v**. I interpret this is not a coincidence, but as an indication that, as Esther Torrego's work has shown, *v** is the locus of parametric variation.

6. The EPP₂ : [person] Checking and Doubling

In this final section I would like to consider the EPP₂, namely, the requirement for SPEC-T_S to be filled by a DP. The literature on this topic is vast, and I do not plan to compare the different proposals made about this particular phenomenon here. For the purposes of this chapter, two questions are worth asking: is the EPP₂ universal?, and, are there alternative strategies to satisfy it?

A fruitful line of inquiry going back to Chomsky (1981), Rizzi (1982), and Taraldsen (1980) argued that sentences like (237) are to be analyzed as in (238), with a null expletive *pro* (*pro*_{EXPL}) satisfying the EPP₂ (see Belletti 2004 for recent discussion).

¹⁰⁷ There are, of course, other possibilities. If one wants to stick to a cartographic account (in line with Cardenaletti's 1997; 1999; 2004 work), it could be assumed that, the three subject positions are the ones in (i), (ii), (iii):

- | | | | | | | | | | | | | |
|-------|---|----------------|----|----------------|----------------|----------------|------------|---|---|-----|-----|-----|
| (i) | [| <i>Subject</i> | C* | [| T _S | [| <i>v</i> * | [| V | ... |]]] | SVO |
| (ii) | [| C* | [| <i>Subject</i> | T _S | [| <i>v</i> * | [| V | ... |]]] | VSO |
| (iii) | [| C* | [| T _S | [| <i>Subject</i> | <i>v</i> * | [| V | ... |]]] | VOS |

If correct, then Spanish should be analyzed as a generalized V2 language, with the verb occupying the C position in simple declarative clauses. I will not pursue this possibility here.

feature on T_S . Let us consider this proposal, for it seems to have received much attention in the literature.

Putting aside the plausible phonological nature of verb movement, evidence indicates that Alexiadou & Anagnostopoulou's (1998) approach cannot be correct. First, if the EPP_2 reduced to the checking of a [person]/D feature in T_S (see Boeckx 2003b; 2006b and Chomsky 2001), this account disregards the fact that, as a matter of simple logic, EAs are potential interveners, blocking Agree between T_S and the v^*-V complex. Second, it cannot be the case that T_S 's [person] is valued by v^*-V 's [person] in a system like Chomsky's (2000; 2001): that would predict that subjects and objects must always have the same [person] specification –a trivial example like *I love Mary* would be impossible. A third argument against Alexiadou & Anagnostopoulou's (1998) proposal is provided by Torrego's (2002) analysis of raising structures. As we saw above, Torrego (2002) shows that Agree between matrix T_S and the subject DP within the embedded clause is blocked by experiencer clitics in Spanish:

(240)

a. [C^*P C^* [TP Juan_i T_S parece [CP C [TP t_i leer mucho]]]] (Spanish)

Juan seem-3.SG read-INF much

'Juan seems to read a lot'

b. * [C^*P C^* [TP Juan_i T_S me parece [CP C [TP t_i leer mucho]]]] (Spanish)

Juan CL-to-me seem-3.SG read-INF much

'Juan seems to me to read a lot'

As Esther Torrego (p.c.) observes, a null counterpart of *it* (call it pro_{it}) must merge with T_S in cases like (241), satisfying the EPP_2 , for otherwise there would be no way to explain the intervention effect in (241b):¹⁰⁹

¹⁰⁹ The same conclusion can be drawn from (i), which presumably involves a null counterpart of *there* (call it pro_{there}). In this case, the problem is that *Me* (Eng. *me*) blocks Agree between matrix T_S and pro_{there} .

(i) (*Me) parecen [pro_{there} haber sido arrestados muchos hombres] (Spanish)
 CL-to-me seem-3.PL have-INF been arrested many men
 'There seem to me to have been arrested many men'

(241)

a. [_{C*P} C* [_{TP} T_S Parece [_{CP} C [_{TP} *pro*_{it} T_S llover]]]] (Spanish)
 seem-3.SG pro rain-INF
 ‘It seems to be raining’

b. * [_{C*P} C* [_{TP} T_S Me parece [_{CP} C [_{TP} *pro*_{it} T_S llover]]]] (Spanish)
 CL-to-me seem-3.SG pro rain-INF
 ‘It seems to me to be raining’

However, (241) does not conclusively prove that matrix T_S must merge something as its SPEC: it just shows that Agree is blocked by the experiencer clitic.

Interestingly enough, indirect evidence from Cecchetto (2000) indicates that matrix T_S does satisfy the EPP₂ by means of a *bona fide* specifier, and not *v**-to-T movement. Following original findings by Zubizarreta (1998; 1999), Cecchetto (2000) argues that clitic left-dislocated dependents reconstruct into a position below preverbal subjects, but above post-verbal ones (an outer-SPEC-*v**, I assume). Such a reconstruction pattern is supported by (242), which shows that the subject DP, *Juan*, can bind the clitic pronoun *le* only when in preverbal position.

(242)

a. [_{C*P} [Los libros que le_z diste]_j, C* [_{TP} Juan_z T_S no los_j ha leído [t_j [_{v*P} t_z *v** t_j]]]] (Spanish)
 the books that CL-to-him give-PAST-2.SG Juan not CL-them have-3.SG read
 ‘The books you gave him, Juan has not read them’

b. * [_{C*P} [Los libros que le_z diste]_j, C* [_{TP} T_S no los_j ha leído [t_j [_{v*P} Juan_z *v** t_j]]]] (Spanish)
 the books that CL-to-him give-PAST-2.SG not CL-them have-3.SG read Juan
 ‘The books you gave him, Juan has not read them’

Yet the crucial empirical test is (243): the Condition (C) effect of this structure indicates, under Cecchetto’s (2000) analysis, that a covert subject (a little *pro*) has undergone internal Merge from SPEC-*v** to SPEC-T_S, checking the EPP₂.¹¹⁰

¹¹⁰ If correct, this provides evidence against Picallo (1998), who argues that a null *pro* cannot be postulated because it has no effect on the interface components. This must be qualified: it is true that *pro* has no PHON effect, but it does feed the SEM component (a claim also made by Belletti 2004), as the binding facts show.

- (243) * $[_{C^*P}[\text{Los libros de María}]_i C^*[_{TP} \text{pro}_j T_S \text{los}_i \text{ha leído } [_{v^*P} t_i [_{v^*P} t_{pro} v^* t_i]]]]$ (Spanish)
the books of María, CL-them have-3.SG read
‘María’s books, she has read them’

But even if this conclusion is correct, we want to know why. A plausible rationale can be drawn from the very nature of T_S . Much recent research (see Demirdache & Uribe-Etxebarria 2000, Hale & Keyser 1998; 2002, and Pesetsky & Torrego 2004) argues that tense heads and prepositions belong to the same syntactic species: they are birelational predicates. Thus, if T_S is really a species of P, it should come as no surprise that it needs to fill in its SPEC to take its second argument. Given that such a requirement is something imposed by the SEM component, it is independent from parameters by definition, and hence universal.

To conclude, I want to consider the analysis of the EPP_2 put forward by Boeckx (2006b). This author argues that the EPP_2 is the requirement for T_S to check its [person] feature. The question that arises, as Boeckx (2006b) notes, is why this checking needs to invoke internal Merge, given the availability of long-distance Agree. Boeckx (2006b) suggests that the very nature of [person] features holds the key to the answer: [person] is much like an anaphor (i.e., a variable), so it requires valuation under c-command, just like anaphors do (but see section 3.4.).

In the case of post-verbal subjects, however, Boeckx (2006b) follows Stjepanović (1999; 2003) in that the DP moves to SPEC- T_S but discourse-factors (here, focus) force pronunciation of the lower copy (see Ortega-Santos 2005).

Although I endorse Boeckx’s (2006b) analysis of the EPP_2 , I will not follow his reasoning about post-verbal subjects. Instead, I assume Belletti’s (2005) proposal that a null (referential) *pro*, base generated in a big-DP together with the post-verbal subject, moves to SPEC- T_S , as indicated in (244):

7. Conclusions

This chapter has explored a morphological parameter, largely concerned with the nature of what Uriagereka (1995a; 1995b) calls FP in NSLs. In particular, I have defended that, in addition to the macro-parameter related to *Phase Sliding* (formulated in terms of head movement in the previous chapter), there is a micro-parameter which distinguishes those NSLs which have a ‘hot’ left-peripheral activity (e.g., E.Portuguese, Galician, and Spanish) from those that do not (e.g., Catalan, French, and Italian).

Following traditional ideas that go back to Rizzi’s influential work, the micro-parameter (or *F Parameter*) has been connected to overt (tense) morphology. Bluntly put, if verbal morphology of a language L is ‘richer,’ the verb can move higher in L, boosting its left-peripheral syntax. I find it extremely interesting, as suggested in the last sections, that this C*P-oriented behavior finds a reflex in the *v**P, with languages that allow more activity within the *Left Periphery* of the clause allowing more word orders in the *v**P –specifically, it seems that if a language L can derive VOS by means of *Object Shift*, it can provide itself with a third subject position.

There are also important consequences for Case Theory and word order: first, I have adopted Chomsky’s (1993a; 1995b) domain extension analysis in order to account for nominative Case assignment across shifted objects in VOS structures in languages like Spanish; second, I have argued in favor of defective intervention effects in AUX-OSV sentences (*contra* Broekhuis 2007 and Richards 2004); and third, I have suggested that EAs be always generated below *v**, in SPEC-V, in order to account for the paradigms found in NSLs languages: EAs never remain in their base position, being forced to move to either SPEC-*v** (post-verbal subjects of both VOS and VSO) or SPEC-T_S (preverbal subjects).

CHAPTER IV ON (SUB-)EXTRACTION

1. Introduction¹

Chapters 2 and 3 were devoted to explore parametric issues which concern the Case/agreement systems and *Phase Theory*. This chapter focuses on an issue that was mentioned (but put aside) in chapter 2 when exploring evidence in favor of phasehood, namely, the special status of phasal specifiers (so-called *edges*) in Chomsky's (to appear) system.

Aiming at reinforcing the key computational role of these positions, Chomsky (to appear) claims that *edges* impose a locality constraint that blocks sub-extraction, as depicted in (1):

(1) PHASE EDGES

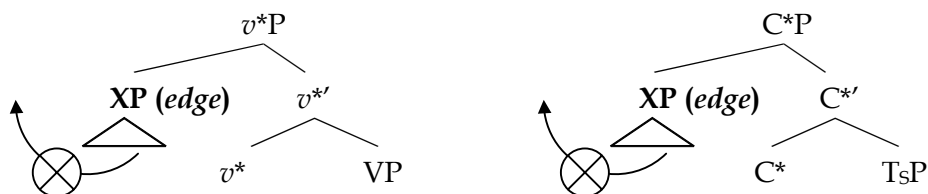

In this chapter I propose an account of islandhood that departs from merely configurational approaches (like those in Chomsky 1986a; to appear). In particular, building on the analyses put forward in Gallego (2005) and Gallego & Uriagereka (2007; to appear), I argue that islandhood is related to the interaction of Case and agreement.

The gist of the account to be provided is already in Boeckx (2003a), who claims that for a domain to be permeable it must establish an Agree dependency. Crucially, as Boeckx (2003a) emphasizes, once that domain agrees, it becomes opaque: in other words, it cannot re-agree. I will phrase this idea as follows:

¹ The discussion in sections 3 and 6 partially reproduce joint work with Juan Uriagereka, cited as Gallego & Uriagereka (2007; to appear).

(2) AGREEMENT CONDITION ON (SUB-)EXTRACTION (ACoE first version)

Syntactic objects that can establish an Agree dependency are transparent

That the idea in (2) can be seriously entertained is shown by Boeckx (2003a) not only in cases where a DP has already agreed with a Probe that assigns it structural Case (and thus cannot agree again), but also in cases where DPs receive inherent Case. According to Boeckx (2003a), the latter DPs have inert φ -features. Recall that, as argued in chapter 2, DPs bearing inherent (i.e., oblique) Case are always introduced by a preposition.

Recent findings by Rackowski & Richards (2005) reinforce Boeckx’s (2003a) proposal. Rackowski & Richards (2005) claim that every case of sub-extraction from a complement domain involves a complex (*multiple*, in Hiraiwa’s 2005 sense) Agree dependency: if one wants to sub-extract a wh-phrase moved to the edge of a phase (typically, the C*P), then the embedding v^* must first agree with C*, and then, with the wh-phrase itself.²

(3) Multiple Agree Approach to Sub-Extraction

Step 1: [_{C*P} C* [_{v*P} v* [_{C*P} who C* [_{v*P} t_{who} v* t_{who}]]]] Agree (v*, C*)

Step 2: [_{C*P} C* [_{v*P} v* [_{C*P} who C* [_{v*P} t_{who} v* t_{who}]]]] Agree (v*, who)

² Rackowski & Richards (2005) also show that for wh-phrases to move to SPEC- v^* , their Case feature must be matched. This is shown by (i), where according to Rackowski & Richards (2005) Agree (v^* , *adobo*) is signaled by the *ang*-marker (which forces a specific reading) and the accusative Case morphology in the verb:

- (i) Lu - lutu - **in** ng lalaki ang adobo. (Tagalog)
 ASP - cook - ACC CS man ANG adobo
 ‘The man will cook the adobo’

[from Rackowski & Richards 2005: 569]

The process in (i) can be captured by assuming both v^* and the DP *adobo* to share T features, as I argued in chapter 2.

In Rackowski & Richards's (2005) own words:

Extraction out of a complement clause therefore seems to require *v* to Agree with the complement clause. This, of course, is what the theory developed in the previous section predicted; in order for *v* to Agree with a *wh*-phrase in the complement clause, *v* must first Agree with the complement clause itself, thereby making it transparent and making the embedded *wh*-phrase accessible to Agree.

[from Rackowski & Richards 2005: 587]

I will return to some questions that Rackowski & Richards's (2005) analysis rapidly pose, most importantly: what the feature *v** and C* share is.

Notice that there is no incompatibility between Boeckx (2003a) and Rackowski & Richards (2005): for all these scholars, one can extract XP out of YP, if YP undergoes Agree. If agreement is impossible or else it has already occurred, sub-extraction fails.

Conceptually too, it is reasonable to relate islandhood to agreement, as Boeckx (2003a) does: if the status of some islands vary from language to language (see Stepanov 2001), it makes more sense to look for the key factor to islandhood within the agreement systems, as these vary crosslinguistically (I know of no changes in the phrase structure component of languages that can be compared to the ones found in the agreement realm; but see Boeckx 2003f).

I want to qualify Boeckx's (2003a) (and, to a less extent, Rackowski & Richards's (2005) analysis by considering why agreement is responsible for islandhood if, after all, φ -features always remain in some island domains (e.g., subjects, and also some objects)? In other words, it is not immediately obvious how, say, a subject DP is transparent before agreement, but opaque after it, since nothing has changed in such DP as far as φ -features are concerned (they never delete, because they are interpretable).

To overcome this issue I will focus on something that does change in DPs: Case. I therefore want to pursue a complementary flipside of Boeckx's (2003a) proposal and relate islandhood to both agreement and Case features. More particularly, I want to defend that Case allows Probes to establish Agree with syntactic objects: it is unvalued T (Case) on D that allows the φ -features of D to be matched, making the matched DP

‘transparent.’ This makes the next prediction: *syntactic objects bearing valued T will block φ -feature Match.*

In the system I have endorsed here, two types of elements bear valued T: DPs that have already been assigned Case and PPs.

Let us formalize this as follows, a modified version of (4):

(4) CASE/AGREEMENT CONDITION ON (SUB-)EXTRACTION (C/ACoE final version)

- a. A syntactic object whose φ -features can be matched is transparent
- b. φ -features of a syntactic object can be matched if it bears *unvalued T*

An additional advantage of (4) is that it is entirely consistent with Chomsky’s (2000b; 2001) *Activity Condition*: Case (here, T-features) renders elements active, capable of participating in syntactic operations.

Viewed this way, it is not that φ -features of adjuncts are inert, as per Boeckx (2003a): they are not (because they do not delete), but cannot be matched, because ‘valued T’ acts as a syntactic shield. This allows for a principled explanation of why these dependents behave as islands: since they are typically introduced by a preposition, we expect adjuncts to be immune to agreement, and, consequently, opaque to sub-extraction.

The chapter is divided as follows: section 2 introduces the notion of islandhood, considering some previous approaches to this phenomenon; section 3 is devoted to Chomsky’s (to appear) analysis of Huang’s (1982) *Subject Condition*, hence it concentrates on the first phase edge, SPEC-*v**, considering the two relevant candidates occupying that position (subjects and shifted objects); in sections 4 and 5 I consider the syntactic dependency between verbs, embedded C*Ps, and adjuncts; section 6 explores the different sub-extraction scenarios that concern SPEC-C*; finally, section 7 offers a brief set of conclusions.

2. Locality Revisited: *Cycles, Barriers, and Phases*

A profuse line of inquiry culminating in Chomsky (1986a) pursued the hypothesis that constraints on extraction follow from configurational considerations that are parasitic on notions such as *government* or *L-marking*. That was the key intuition behind *barrierhood*: object DPs are ‘transparent’ domains because the verb manages to create the appropriate environment for sub-extraction to go through. Other dependents (broadly, subjects and adjuncts) are opaque due to their configurational status –they are dependents with no lexical head (properly) governing them. This was, details aside, the logic of Huang’s (1982) *Condition on Extraction Domains* (CED):

(5) CONDITION ON EXTRACTION DOMAINS

A phrase A may be extracted out of a Domain B only if B is properly governed

[from Huang 1982: 505]

The relevant (i.e., object vs. non-object) asymmetry is illustrated in (6):

(6)

- a. [_{C*P} Who_i C* did you hear [a story about t_i]]? *Sub-extraction from Object*
 - b. *[_{C*P} Who_i C* did [a story about t_i] amuse you]? *Sub-extraction from Subject*
 - c. *[_{C*P} Which book_i C* did John go to class [after he read t_i]]? *Sub-extraction from Adjunct*
- [from Lasnik & Saito 1992: 42,12]

Such a configurational account drew a dramatic line between *complements* and *specifiers* (see Chomsky 1995b, Kayne 1994, Starke 2004, and Uriagereka 1999a). Implicit behind these investigations was the idea that the latter are problematic dependents for which specific licensing mechanisms (e.g., m-command, SPEC-head agreement, EPP features, and so on) have to be posited.

This overall approach to islandhood has remained virtually intact to the present: regardless of the particular perspective from which this phenomenon has been explored (e.g., Nunes 2004, Ormazabal et al. 1994, Rizzi 2006, Stepanov 2001, Takahashi 1994, and Uriagereka 1999a), it is *complex specifiers* that pose problems. Perhaps the

Case/agreement systems (e.g., resumption, expletives, agreeing vs. non agreeing subjects, clitic doubling, Case marked objects, etc.).

As said, the process rendering active XPs opaque is referred to as “freezing” in the recent literature, and can be thought of as indicated in (11):

(11) **FREEZING (of subjects in SPEC-T_S)**

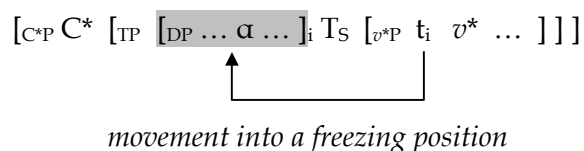

The idea in (7) and (11) is borrowed from Wexler & Culicover’s (1981) *Freezing Principle*, which has been recruited by Bošković (2005), Ormazabal et al. (1994), Rizzi (2006), Stepanov (2001), and Takahashi (1994) in different fashions:

(12) **FREEZING PRINCIPLE**

- (i) If a node A of a phrase marker is frozen, no node dominated by A may be analyzed by a transformation.
- (ii) If the immediate structure of a node in a phrase marker A is nonbase, that node is *frozen*.
- (iii) The *immediate structure* of A is the sub-phrase marker consisting of A, the nodes A_1, A_2, \dots, A_n that A immediately dominates, in order, and the connecting branches.
- (iv) The immediate structure of A is a *base immediate structure* if $A \rightarrow A_1, A_2, \dots, A_n$ is a base rule. Otherwise, it is nonbase.

[from Wexler & Culicover 1981: 119]

As Stepanov (2001) notes, at the end, freezing reduces to (13):

(13) **FREEZING EFFECT**

No extraction is possible out of a previously moved domain

[from Stepanov 2001: 52]

Going back to the *Activity Condition* as understood by Chomsky (2000; 2001), it is important to highlight that for such ϕ -freezing to take place, the relevant Probe must be ϕ -complete. Thus, the specifiers of ϕ -defective Probes should in principle allow sub-extraction. According to Chomsky (to appear), in fact, they do:

(14) **T ϕ -complete vs. T ϕ -defective**

- a. * $[_{C^*P}$ Of which car_z C^* did $[_{TP}$ [the driver t_z] $_i$ T_S [$_{v^*P}$ t_i v^* cause a scandal]]]?
- b. $[_{C^*P}$ Of which car_z C^* is $[_{TP}$ [the driver t_z] $_i$ T_S likely [t_i to [$_{v^*P}$ t_i v^* cause a scandal]]]]?
- c. $[_{C^*P}$ Of which car_z C^* did they believe [the driver t_z] $_i$ $[_{TP}$ t_i T_S to [t_i have caused a scandal]]]?

[from Chomsky to appear: 20]

In these examples, the DP subject *the driver of which car* undergoes successive cyclic A-movement from the base position, SPEC- v^* , to the final landing site, matrix SPEC- T_S . Crucially, Chomsky (to appear) argues that an edge-Probe launched from matrix C^* can target the wh-chunk of *which car* along the A-movement path, in a parallel fashion, so that sub-extraction occurs from a non-freezing, ϕ -defective, specifier. This is illustrated in (15), which corresponds to the raising case:

(15) *Sub-extraction from Specifiers of ϕ -defective T_S*

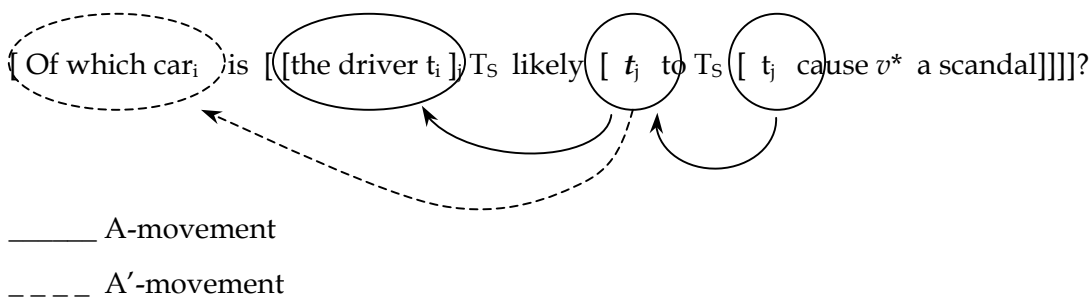

Also relevant to *Activity Condition*-based accounts is the observation, due to Cinque (1990),³ that standard configurational accounts fail to handle contrasts like those in (16):

³ See Cinque (1996), Rizzi (1990; 1991; 2001b; 2004), and Starke (2001) for additional discussion.

(16)

a. [_{C*P} Qué paquete_i C* no sabes [_{C*P} cuánto_j C* pesa t_i t_j]] (Spanish)

what package not know-2.SG how-much weigh-3.SG

‘Which package don’t you know how much it weighs’

b. * [_{C*P} Cuánto_j C* no sabes [_{C*P} qué paquete_i C* pesa t_i t_j]]? (Spanish)

how-much not know-2.SG what package weigh-3.SG

‘How much don’t you know which package weighs?’

[from Bosque 1994: 174]

Cases like (16b) indicate that not every kind of DP can be successfully extracted out of weak islands.⁴ In line with Starke (2001), one might take the extractable DPs to be endowed with a feature indicating “D(iscourse)-linking,” “presuppositionality,” or “aboutness.” Thus the relevant scenario would roughly be as depicted in (17b), where α and β (which we can think of as Probe and Goal) try to establish a syntactic dependency of the Agree sort, ignoring δ : Starke’s (2001) suggestion is that if α and β are F1-related, intervention will ensue, but if they are just F2-related (F2 would instantiate the [D-linking] or [topic] feature I just mentioned), no intervention emerges, as the intervener, δ , is not ‘of the same type:’

(17) MINIMALITY EFFECTS

a. $\alpha_{[F]}$. . . $\delta_{[F]}$. . . $\beta_{[F]}$ *standard minimality*

b. $\alpha_{[F1][F2]}$. . . $\delta_{[F1]}$. . . $\beta_{[F1][F2]}$ *complex minimality*

In recent work, configurational approaches to islandhood (like that of Chomsky’s 1986a *Barriers* framework) have been revamped. Specifically, Chomsky (to appear) takes Huang’s (1982) CED effects to be ruled by phrase structure factors, like unstable {XP, YP} configurations and pair Merge:

Minimal search is not uniquely defined in *XP-YP structures* where neither XP nor YP is a head: *the “wrong choice” yields island effects.*

[from Chomsky to appear: 13 –emphasis added, AJG]

⁴ Bosque (1994) treats the quantificational DP *cuánto* (Eng. *how much*) in (16) as an argument. See Real (2006) for a different analysis.

Consider the CED effects discovered by Huang (1982), involving XP-YP structures with island violations under the wrong choice. The adjunct-island subcase follows if an adjunct is not in the search domain of the probe. That in turn follows from the approach to adjuncts in Chomsky (2004), taking them to be entered into the derivation by pair-Merge instead of set-Merge to capture the fundamental asymmetry of adjunction. [from Chomsky to appear: 13]

As mentioned in chapter 2, Chomsky (to appear) suggests that phase edges are responsible for island effects. In the next section I discuss Chomsky's (to appear) analysis, which claims that, rather than related to the surface position of subjects (i.e., SPEC-T_S), the *Subject Condition* pertains to their base position: SPEC-*v**, a phase edge. Chomsky (to appear) provides the pair in (18) to illustrate this point:

(18)

- a. *[_{C*P} Of which car_i C* did [_{TP} [the driver t_i]_j T_S [_{v*P} t_j v* cause a scandal]]]?
 b. [_{C*P} Of which car_i C* was [_{TP} [the driver t_i]_j T_S [_{vP} v awarded t_j a prize]]]?

[from Chomsky to appear: 14]

As Chomsky (to appear) points out, the data in (18) are incompatible with the *Subject Condition* being related to SPEC-T_S: one should then expect both examples to be out, for the subject ends up occupying SPEC-T_S in both instances. Puzzlingly, (18a) seems worse than (18b). In this respect, Chomsky (to appear) suggests that phase edges create a locality problem:

Consider the subject-island subcase. It has been assumed since Huang's discovery of these properties that the surface subject is the island, but there is reason to doubt this assumption [...] the effect is determined by the base structures [...] not the surface structures [...] [I]t remains to explain why the probe for wh-movement cannot readily access the wh-phrase within the external argument of *a*. That could reduce to a locality condition: which in *a* is embedded in the lower phase, which has already been passed in the derivation. We know that the external argument itself can be accessed in the next higher phase, but there is a cost to extracting something embedded in it. [from Chomsky to appear: 13-14 –emphasis added, AJG]

Noam Chomsky elaborates on this through personal communication:

Extraction from within SPEC of a phase already passed poses a locality problem, by definition. It's necessarily not only to search into the exterior of the phase already passed (which is clearly OK), but also one level of depth further, into the interior of that exterior. Whether that deeper search is in fact legitimate is another question.

In Gallego & Uriagereka (2007) we propose an *Edge Condition* in order to capture the fact that edges freeze the internal part of syntactic objects, not syntactic objects in full:

(19) **EDGE CONDITION**

Syntactic objects in phase edges are internally frozen

[from Gallego & Uriagereka 2007: 19]

Chomsky's (to appear) proposal can thus be seen as a strategy to strengthen the leading role of phase edges, the positions that give rise to interpretive and computational effects of the cyclic sort in his system.

Consequently, both SPEC-T_S and SPEC-*v** render DPs opaque, but for different reasons: SPEC-*v** does so by pure locality (our *Edge Condition*), while SPEC-T_S does so by means of Case/agreement-freezing (the *Activity Condition*).

By parity of reasoning one would expect the *Edge Condition* to apply in the other phase edge as well, SPEC-C*, and that is what Chomsky (to appear) suggests, evoking data originally noted by Esther Torrego in the mid 80s and cited in Chomsky (1986a). However, the facts become more complex at this point, as Torrego's (1985) data were actually judged as grammatical:

- (20) [_{C*P} De qué autora_z C* no sabes [_{C*P} [qué traducciones t_z]_i C* . . .
of what author not know-2.SG what translations
. . . [_{TP} t_i han ganado premios internacionales]]? (Spanish)
have-3.PL won awards international
'Which author don't you know what translated books have won awards?'

[from Torrego 1985: 31]

As pointed out by Rizzi (2006), the same type of sub-extraction is possible in Italian:

(21)

- a. $?[_{C^*P}$ Di quale autore_z C* ti domandi $[_{C^*P}$ [quanti libri t_z]_i C* . . .
of which author CL-to-you wonder-2.SG how-many books
. . . $[_{TP}$ siano stati censurati t_i]]] (Italian)
be-3.PL been censored

‘Which author do you wonder how many books by have been censored?’

- b. Gianni, $[_{C^*P}$ del quale_z C* mi domando $[_{C^*P}$ [quanti libri t_z]_i . . .
Gianni, of-the which CL-to-me wonder-1.SG how-many books
. . . siano stati censurati t_i]]] (Italian)
be-3.PL been censored

‘Gianni, whom I wonder how many books by have been censored’

[from Rizzi 2006: 114-116]

Finally, to complicate things even further, consider (22), from Lasnik & Saito (1992), the only data consistent with Chomsky’s (to appear) analysis.

(22)

- a. $??[_{C^*P}$ Who_i C* do you wonder $[_{C^*P}$ [which picture of t_i]_j C* Mary bought t_j]] ?
b. $??[_{C^*P}$ Who_i C* do you wonder $[_{C^*P}$ [which picture of t_i]_j C* t_j is on sale]] ?

[from Lasnik & Saito 1992: 102]

Though problematic at first blush, the Romance-English asymmetry could simply follow from particular morphological mechanisms that Romance can resort to for sub-extraction purposes. This possibility is consistent with the ability to circumvent Wh-islands exhibited by Romance (see chapter 3):⁵

⁵ See also Lasnik & Saito (1992: 11-12), who note that the English counterpart of (i) is severely degraded (??, according to them):

(i) $[_{C^*P}$ Qué libro_i C* no sabes $[_{C^*P}$ por qué_j C* te han regalado t_i t_j]] ? (Spanish)
what book not know-2.SG for what CL-to-you have-3.PL given
‘Which book don’t you know why they have given you?’

(23)

a. *_{[C*P} Which student_i C* do you wonder [_{C*P} how_j C* t_i could solve the problem t_j]]?

b. [_{C*P} Che studente_i C* non sai [_{C*P} come_j C* potrà t_i risolvere . . .

what student not know-2.SG how will-manage solve-INF

. . . il problema t_j]]?

(Italian)

the problem

‘Which student don’t you know how will manage to solve the problem?’

[from Rizzi 1990: 73]

Rizzi (2006) studies different cases of sub-extraction from left peripheral positions, concluding that there is a freezing effect affecting criterial positions (those determining an interpretive import: SPEC-Focus, SPEC-Topic, etc.). Rizzi (2006) dubs this mechanism *Criterial Freezing*:

(24) **CRITERIAL FREEZING (non-final version)**

A phrase meeting a criterion is frozen in place

[from Rizzi 2006: 112]

(24) is akin to Bošković’s (2005) *Operator Freezing Effect*, which takes all XPs undergoing A-bar displacement to bear an uninterpretable operator feature [Op] that renders them active:

(25) **OPERATOR FREEZING EFFECT**

Operator in operator-variable chains cannot undergo further operator-movement

[from Bošković 2005: 1]

According to Bošković (2005), when the XP endowed with the [Op]-feature reaches the SPEC of the head bearing the relevant interpretable counterpart, XP is frozen.

Notice that Rizzi’s (2006) criterial positions seem to naturally qualify as edge ones (see Chomsky 2001) –if so, (24) is compatible with our (19).⁶

⁶ It is necessary to clarify that *criterial positions* and *edge positions* do not entirely overlap: while every SPEC-C* and SPEC-*v** qualifies as an edge, not every SPEC-C* and SPEC-*v** qualifies as a criterial SPEC. For instance, intermediate SPECS in long-distance displacement do not yield semantic effects.

In the remainder of this chapter I investigate the validity of the *Edge Condition* and *Criterionial Freezing* in the light of Chomsky’s *Phase Theory*. I will argue that although the *Edge Condition* is too strong for the *Subject Condition*, it appears to be correct as far as the Torrego (1985)/Rizzi (2006) paradigm is concerned.

3. Sub-extraction from SPEC-*v**

This section discusses sub-extraction from dependents occupying SPEC-*v**: subjects (EAs) and shifted objects. After considering different empirical evidence, I conclude that these DPs become islands after their structural Case has been valued, which happens when they reach a position where ‘maxima φ -feature’ checking is done (see Boeckx 2006a). I also explore the effects studied by Kuno (1973), relating them to the availability to sub-extract from non-freezing (φ -defective) specifiers.

3.1. The *Subject Condition*

Before delving into the island effects arising on the first phase edge we need to reproduce Chomsky’s (2000; 2001) PIC (see chapter 2).

(26) **PHASE IMPENETRABILITY CONDITION**

The domain H [of a strong phase] is not accessible to operations at ZP [the next strong phase]; only H and its edge are accessible to such operations.

[from Chomsky 2001: 14]

Recall that, by the PIC, operations within a phase are restricted to the complement domain, the rest being the *edge*:

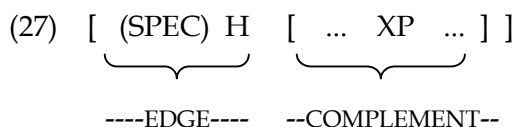

Under this logic, the base position of subjects (EAs) is precisely at *v**P’s *edge*, which can readily be targeted by C*-T_S Probes. The scenario is consistent with previous, not

phase-based, accounts of the *Subject Condition*: when in their base position, subjects never invoke ϕ -freezing, *Chain Uniformity*, or linearization conflicts (see Boeckx 2003a, Ormazabal et al. 1994, and Stepanov 2001 for discussion), so they should be transparent.

Chomsky (to appear), as already mentioned, adduces the asymmetry in (18), reproduced here as (28), to challenge those proposals:

(28)

- a. *[_{C*P} Of which car_i C* did [_{TP} [the driver t_i]_j T_S [_{v*P} t_j v* cause a scandal]]]?
- b. [_{C*P} Of which car_i C* was [_{TP} [the driver t_i]_j T_S [_{vP} v awarded t_j a prize]]]?

[from Chomsky to appear: 14]

This type of data was judged degraded by Kuno (1973) too. Uriagereka (2004) concurs, judging them grammatical, at least in those cases involving sub-extraction from the subject of a small clause, like (29a), with (29b), an ECM structure, being degraded:

(29)

- a. [_{C*P} Which artists_i C* did you find [_{SC} [works by t_i] offensive]]?
- b. *[_{C*P} Which artists_i C* did you find [[works by t_i]_j to t_j be [_{SC} t_j offensive]]]?

[from Uriagereka 2004: 10]

Sabel (2002: 293) also considers these structures, but he judges them as fully out when sub-extraction (not extraction) is at stake:

(30) *Extraction of Subject of SC and ECM*

- a. [_{C*P} Who_i C* does Mary consider [_{SC} t_i stupid]]?
- b. [_{C*P} Who_i C* does Mary believe [_{SC} t_i to t_i be t_i stupid]]

[from Sabel 2002: 293]

(31) *Sub-extraction from Subject of SC and ECM*

- a. *[_{C*P} Who_i C* does Mary consider [_{SC} [friends of t_i] idiotic]]]?
- b. *[_{C*P} Of whom_i C* does Mary consider [_{SC} [friends t_i] idiotic]]]?

- c. * $[_{C^*P}$ Who_i C* does Mary believe [[friends of t_i]_j to t_j be t_j stupid]])?
d. * $[_{C^*P}$ Of whom_i C* does Mary believe [[friends t_i]_j to t_j be t_j stupid]])?

[from Sabel 2002: 293]

By contrast, Kayne (1984: 189) finds some of such examples acceptable, as long as no stranding is at stake (see more discussion in section 3.2.):

(32)

- a. ? $[_{C^*P}$ Of which words_i C* is learning [_{SC} [the spellings t_i] difficult]])?
b. * $[_{C^*P}$ Which words_i C* is learning [_{SC} [the spellings of t_i] difficult]])?

[from Kayne 1984: 189]

Going back to Chomsky's (to appear) contrast, it must be pointed out that it could be accounted for by invoking the *Edge Condition*. Interestingly, not only does the *Edge Condition* cover (18): it also explains cases like (33):

(33)

- a. $[_{C^*P}$ Which candidate_i C* were [_{TP} there T_S [_{vP} v [posters of t_i] all over the town]]])?
b. * $[_{C^*P}$ Which candidate_i C* were [_{TP} [posters of t_i]_j T_S [_{vP} v t_j all over the town]]])?

[from Lasnik & Park 2003: 651]

In (33a) one could argue that sub-extraction goes through because the subject DP does not establish full agreement with T_S, as it does not check [person] (see Boeckx 2003b; 2006b). However, the *Edge Condition* still serves its purpose here, given that vPs do not qualify as (strong) phases for Chomsky (2001).⁷ In short, both the *Edge Condition* and Chomsky's PIC are inapplicable –hence, irrelevant.

In order to test the validity of the *Edge Condition* throughout, let us consider a NSL such as Spanish. As the data in (34) show, a system like Chomsky's (to appear) correctly predicts that sub-extraction from unaccusative (34a) and passive (34b) structures should be possible: since no phase boundary is involved, C*'s edge-Probes can directly target the relevant DPs in their first-Merge position.

⁷ Chomsky (2001) calls these defective vPs 'weak' phases –as opposed to the standard, or 'strong,' (transitive), ones. See Legate (2003) for further discussion.

(34)

- a. [_{C*P} De qué lingüista_i C* han llegado ya [_{vP} v [muchos libros t_i]]]? (Spanish)
of what linguist have-3.PL arrived already many books
‘Which linguist have many books by already arrived?’
- b. [_{C*P} De qué escritor_i C* han [_{vP} v sido [_{PrTP} vendidas [muchas novelas t_i]]]? (Spanish)
of what writer have-3.PL been sold many novels
‘Which writer have many novels by been sold?’

[from Gallego & Uriagereka 2007: 22]

Uriagereka (1988a; 2004) first noted that sub-extraction from subjects of transitive verbs (EAs), on the other hand, is worse –almost barred, for him.⁸

- (35) ??[_{C*P} De qué artistas_i C* han herido [_{TP} T_S [_{v*P} tu sensibilidad_j
of what artists have-3.PL hurt your sensitivity
... [_{v*P} [las obras t_i] v* t_j]]]? (Spanish)
the works
‘Which artists have the works of hurt your sensitivity?’

[from Uriagereka 1988a: 122]

The contrast between (34) and (35) falls into place if subjects of unaccusatives are accessed in their base position: the complement domain of (weak) *v*.

Compare (35) with (36) next:

⁸ To my ear, though, sub-extraction in the following Spanish examples is not too degraded (in section 7 I try to explain why):

- (i) (?) [_{C*P} De qué equipo_i C* han protestado T_S [_{v*P} [muchos jugadores t_i] v*]]?
of what team have-3.PL protested many players
‘Which team have the/much players of protested?’
- (ii) (?) [_{C*P} De qué universidad_i C* te respetan T_S [_{v*P} [muchos estudiantes t_i] v*]]?
of what university CL-you respect-3.PL many students
‘Which university do many students of respect you?’
- (iii) ? [_{C*P} De qué actor de cine_i C* causaron sensación [_{v*P} [las fotografías t_i] v*]]?
of what actor of cinema cause-PAST-3.PL sensation the pictures
‘Which actor did the pictures of caused sensation?’

- (36) * $[_{C^*P}$ De qué artistas_i C* han herido $[_{TP}$ T_S $[_{v^*P}$ [las obras t_i] v*
of what artists have-3.PL hurt the works
... tu sensibilidad]]]? (Spanish)
your sensitivity
‘Which artists have the works of hurt your sensitivity?’

[from Gallego 2005: 74]

(36) indicates that sub-extraction from non-final post-verbal subjects is much worse than sub-extraction from final post-verbal ones. Although the contrast is clear enough, it is not obvious why things should be so if (as I am assuming) subjects occupy the same position in (35) and (36). Further inquiry is needed to prove this assumption correct (see section 7).

Interestingly, a similar asymmetry was already reported by Uriagereka (1988a), who shows that sub-extraction from post-verbal subjects is preferred to sub-extraction from preverbal ones (in this case, the contrast is much clearer).

- (37) $[_{C^*P}$ De qué conferenciantes_i C* te parece que ... (Spanish)
of what speakers CL-to-you seem-3.SG that
a. ... (?) $[_{TP}$ T_S me_z van a impresionar_v $[_{v^*P}$ [las propuestas t_i] v* t_z t_v]]])?
CL-to-me go-3.PL to impress-INF the proposals
b. ... * $[_{TP}$ [las propuestas t_i]; T_S me_z van a impresionar_v $[_{v^*P}$ t_j v* t_z t_v]]])?
the proposals CL-to-me go-3.PL to impress-INF

‘Which speakers does it seem to you that the proposals by will impress me?’

[from Uriagereka 1988a: 118]

The importance of examples like (37a) lies on the fact that the post-verbal subject *las propuestas de qué conferenciantes* (Eng. *the proposals by which speakers*) is in the first-Merge position of a transitive predicate,^{9 10} SPEC-*v**, a *bona fide* phase edge. The prediction, under Chomsky’s (to appear) system, is that (37a) should be out, but it is not.¹¹

⁹ As done in Gallego (2005) and Gallego & Uriagereka (2007; to appear), I limit the data to structures where the object is either not realized at all (conflated, as in Hale & Keyser’s 2002 treatment of unergatives) or else realized as a clitic, concentrating on whether the verb is transitive or not.

By contrast, as we note in Gallego & Uriagereka (2007), it appears that sub-extraction from post-verbal subjects within pseudo-cleft constructions is not possible (I consider this, since this pattern is also focused on by Chomsky to appear):

- (38) *Fue [el coche (no el camión)] [_{C*P} del que_i C* causaron
 be-PAST-3.SG the car (not the truck) of-the which cause-PAST-3.PL
 . . . un escándalo [varios conductores t_i] (Spanish)
 a scandal several drivers
 ‘It was the CAR (not the TRUCK) of which several drivers caused a scandal’
 [from Gallego & Uriagereka 2007: 46]

¹⁰ The verb in (37) might be analyzed as a psychological predicate favoring a post-verbal position for its subject, as M. Lluïsa Hernanz and Luisa Martí observe through personal communication, which might somehow ameliorate sub-extraction (see section 7).

Note, however, that (i), a non-psychological transitive verb, still allows the relevant sub-extraction:

- (i) (?) [_{C*P} De qué equipo_i C* dices [que han bailado [dos participantes t_i]]? (Spanish)
 of what team say-2.SG that have-3.PL danced two participants
 ‘Which team do you say that two members of have danced?’

I return to this issue in section 7.

¹¹ Facts are murkier in Catalan or Italian, where sub-extraction from post-verbal subjects varies from speaker to speaker:

- (i) ?* [_{C*P} Di quale macchina_i C* [_{TP} [il guidatore t_i]_j T_S causò [_{v*P} t_j v* uno scandalo]]?]
 of which car the driver cause-PAST-3.SG a scandal
 ‘Of which driver did the driver cause a scandal?’
 (ii) [_{C*P} Di quale macchina_i C* [_{TP} T_S causò [_{v*P} uno scandalo]_j [_{v*P} [il guidatore t_i] v* t_j]]?]
 of which car cause-PAST-3.SG the driver a scandal
 ‘Of which car did the driver cause a scandal?’

[from Donati 2006b: 4]

Belletti (2004) and Fortuny (2007), on the other hand, find sub-extraction from subjects barred in almost every environment of Italian and Catalan. Consider Italian first:

- (i) ??Il giornale [_{C*P} di cui_i C* ha telefonato [il direttore t_i] al presidente]
 the newspaper of which have-3.SG phoned the director to-the president
 ‘The newspaper whose director has phoned the director’
 (ii) ?* [_{C*P} Di quale giornale_i C* ha telefonato [il direttore t_i] al presidente]?
 of which journal have-3.SG phoned the director to-the president
 ‘Which journal has the director of phoned the president?’

[from Belletti 2004: 20, 43]

As Fortuny (2007) notes, the same carries over to Catalan:

- (iii) * [_{C*P} De quina pel.lícula_i C* va provocar [el director t_i] un escàndol]?
 of which film AUX-3.SG cause-INF the director a scandal
 ‘Of which film did the director cause a scandal?’
 (iv) * [_{C*P} De quina pel.lícula_i C* va provocar un escàndol [el director t_i]]?
 of which film AUX-3.SG cause-INF a scandal the director
 ‘Of which film did the director cause a scandal?’

[from Fortuny 2007: 117]

It is intriguing that Catalan and Italian, contrary to Spanish, can barely circumvent the *Subject Condition*. It is tempting to speculate that this follows from the fact that Spanish allows for more word order possibilities (a more active *v*P* and *C*P* peripheries), as we saw in chapter 3.

(38) appears to us to be degraded, but for irrelevant reasons: additional factors interfere in this type of structure, whose status has been highly debated in the literature (see Brucart 1994b: 151-163 for discussion). Note, in particular, that (39a) and (39b), which are minor parametric variants of (38), are much better:¹²

(39)

a. Fue del coche (no del camión) [_{C*P} del que_i C* causaron un
 be-PAST-3.SG of-the car (not of-the truck) of-the which cause-PAST-3.PL a
 escándalo [varios conductores t_i]] (Spanish)
 scandal several drivers

‘It was the CAR (not the TRUCK) of which several drivers caused a scandal’

b. Fue del coche (no del camión) [_{C*P} C* que causaron un
 be-PAST-3.SG of-the car (not of-the truck) that cause-PAST-3.SG a
 escándalo [varios conductores t]] (Spanish)
 scandal several drivers

‘It was the CAR (not the TRUCK) of which several drivers caused a scandal’

[from Gallego & Uriagereka 2007: 46-47]

I cannot address the specifics of these pseudo-cleft constructions here (see Brucart 1994b for an analysis), but the key thing is this: in both (39a) and (39b), the relative clause where sub-extraction takes place is left intact (only the focused constituent’s categorial status is modified: *el coche* vs. *del coche*), and the outcome is fine.

Importantly for our analysis, if the subject leaves its base position, sub-extraction should be degraded, as in Uriagereka’s (1988a) data. (40) shows that the prediction is borne out.

¹² The contrast between (38) and (39) is reminiscent of the discussion in Kuno (1973) with respect to pied-piping. See below.

(40)

- a. ??Fue del coche (no del camión) [_{C*P} del que_i C*
 be-PAST-3.SG of-the car (not of-the truck) of-the which cause-PAST-3.PL
 [_{TP} [varios conductores t_i]_j T_S causaron [_{v*P} t_j v* un escándalo]]] (Spanish)
 several drivers cause-PAST-3.SG a scandal

‘It was the CAR (not the TRUCK) of which several drivers caused a scandal’

- b. ??Fue del coche (no del camión) [_{C*P} Op_i C* que
 be-PAST-3.SG of-the car (not of-the truck) that
 [_{TP} [varios conductores t_i] T_S causaron [_{v*P} t_i v* un escándalo]]]] (Spanish)
 several drivers cause-PAST-3.PL a scandal

‘It was the CAR (not the TRUCK) of which several drivers caused a scandal’

[from Gallego & Uriagereka 2007: 47]

Similar observations are made by Broekhuis (2005), who provides Dutch data involving the *wat-voor*-split phenomenon. Just as seen in the Spanish examples in (37), the contrast between (41) and (42) below shows that sub-extraction from subjects is possible only if these stay in their first-Merge position: SPEC-*v**.

Consider first sub-extraction from IAs. According to Chomsky (to appear), this operation should yield a grammatical result, independently of the final (landing) site of the object. Facts, however, prove otherwise: when moved to SPEC-T_S, sub-extraction is ruled out.

(41)

- a. [_{C*P} Wat_i C* zijn [_{TP} (er) T_S [_{vP} v jouw vader [t_i voor rare verhalen] verteld]]]?
 what be-3.PL EXP your father for strange stories told

‘What kind of strange stories have been told your father?’

- b. * [_{C*P} Wat_i C* zijn [_{TP} [t_i voor rare verhalen]_j T_S [_{vP} v jouw vader t_j verteld]]]?
 what be-3.PL for strange stories your father told

‘What kind of strange stories have been told your father?’

[from Broekhuis 2005: 64-65]

Consider now sub-extraction from a non-derived subject (again, data are from Dutch):

(42)

- a. [_{C*P} Wat_i C* hebben [_{TP} er T_S [_{v*P} [t_i voor mensen] v* je moeder bezocht]]]?
 what have-3.PL EXP for people your mother visited
 ‘What sort of people has visited your mother?’
- b. *[_{C*P} Wat_i C* hebben [_{TP} [t_i voor mensen] T_S [_{v*P} t_j v* je moeder bezocht]]]?
 what have-3.PL for people your mother visited
 ‘What sort of people has visited your mother?’

[from Broekhuis 2005: 65]

Considered together, these facts are telling enough: it does not matter whether sub-extraction targets a base object or a base subject –what is important is whether the relevant DP has been de-activated by means of the T-Probe launched from the C*-T_S complex: when moved to SPEC-T_S, subjects stop being active, which blocks further agreement, and, as a consequence, sub-extraction.

Notice that the overall analysis presupposes that only preverbal subjects display full agreement. This assumption is supported by the data in (43):^{13 14}

(43)

- a. {Han/ha} llegado tu padre y tu hermano. (Spanish)
 have{3.PL/3.SG} arrived your father and your brother
 ‘Your father and your brother have arrived’

¹³ As pointed out in chapter 3, the agreement datum is a classical observation, first noted by Bello (1847). See Camacho (2003) for updated discussion.

¹⁴ Juan Uriagereka observes through personal communication that full-agreeing subjects block sub-extraction even if these remain *in situ*. This can be seen with the existential impersonal sentences in (i) and (ii), whose standard agreement pattern involves default agreement (i.e., [person 3]). However, for a large group of speakers (in which I am not included), full agreement is possible. In the latter cases, sub-extraction is worse.

- (i) [_{C*P} De qué escritor_i C* [_{TP} T_S había [_{vP} v [muchos libros t_i] encima de la mesa]]]?
 of which writer there-be-PAST-3.SG many books over of the table
 ‘Which writer were there many books by over the table?’
- (ii) ??[_{C*P} De qué escritor C* [_{TP} T_S habían [_{vP} v [muchos libros t_i] encima de la mesa]]]?
 of which writer there-be-PAST-3.PL many books over of the table
 ‘Which writer were there many books by over the table?’

- b. Tu padre y tu hermano {han/*ha} llegado. (Spanish)
 your father and your brother have{3.PL/3.SG} arrived
 ‘Your father and your brother have arrived’

[from Uriagereka 2004: 25]

The conclusion is further reinforced by (44), where sub-extraction from base objects yields deviance when these move to SPEC-T_S:

(44)

- a. [_{C*P} De qué países_i C* quieres [_{C*P} C* que [_{vP} v vengán [muchos delegados t_i]]]]?
 of what countries want-2.SG that come-3.PL many representatives
 ‘Which country do you want many representatives of to come?’
- b. ??[_{C*P} De qué países_i C* quieres que [_{TP} [muchos delegados t_i]_j T_S [_{vP} v vengán t_j]]]?
 of what countries want-2.SG that many representatives come-3.PL
 ‘Which country do you want many representatives of to come?’

[from Gallego & Uriagereka 2007: 25-26]

The fact that sub-extraction from the preverbal subject in (44b) is degraded, even when C*’s edge-Probe can target the transparent base position, is unexpected within Chomsky’s (to appear) system. Things are different within Boeckx’s (2003a) approach: sub-extraction targets the subject in its derived position, SPEC-T_S, where de-activation has already occurred.

To be sure, one can think of alternative strategies to tackle the facts. Perhaps post-verbal subjects pass through a position analogous to ϕ -defective T_S, rendering them transparent, or else sub-extraction exceptionally obtains due to the semantic (focal) interpretation of post-verbal subjects.

The first possibility is tempting, but unavailable within the minimalist framework, where only two subject positions, SPEC-*v** and SPEC-T_S, are assumed.¹⁵ In turn the possibility of focal interpretation of subjects would face additional difficulties under a proposal along the lines of Belletti’s (2004), where post-verbal subjects are said to move

¹⁵ Plus the base one, SPEC-V, as previously discussed (see chapter 3). See Cardinaletti (1997, 1999; 2001a; 2004) for a different view.

to a left-peripheral functional projection above the *v**P –given the logic of Belletti’s (2004) analysis, satisfaction of a *Focus Criterion* should trigger a freezing effect blocking sub-extraction, contrary to fact.¹⁶

Clausal subjects constitute a final datum in favor of a C/ACoE based account put forward here. In Spanish, clauses can be introduced by a definite article, but there is a preference for having it when the clause is in preverbal position. One could take that as additional evidence for richer agreement in preverbal position.

(45)

a. (El) que leas tanto es sorprendente. (Spanish)

the that read-SUBJ-2.SG so-much be-3.SG surprising

‘That you read so much is surprising’

b. ?/??Es sorprendente el que leas tanto. (Spanish)

be-3.SG surprising the that read-SUBJ-2.SG so-much

‘It is surprising that you read so much’

As noted by Uriagereka (1988a), the definite article introduces clauses when they are subjects, not objects (with the only exception of factive verbs):

(46)

a. El que vengas les impresiona. (Spanish)

the that come-SUBJ-2.SG CL-to-them impress-3.SG

‘That you come impresses them’

b. *Quieren el que vengas. (Spanish)

want-3.PL the that come-SUBJ-3.SG

‘They want that you come’

[from Uriagereka 1988a: 121-122]

All other things being equal, the presence of the article should not be innocuous, and in fact it is not. Consider (47), which is similar to (45): again, the subject clause is

¹⁶ Yet a third route is pursued by Gallego (2005), and, following him, Gallego & Uriagereka (in press). Assuming Chomsky’s (to appear) phase based analysis, in those papers it is argued that *Phase Sliding* (chapter 2) redefines phase boundaries, rendering SPEC-*v** within the *complement domain* of *v**-*T*_s, and thus transparent for sub-extraction.

either preverbal or post-verbal, and, again, only the former has the possibility of showing the article.

(47)

- a. (El) que Juan haya leído esos libros es sorprendente. (Spanish)
 the that Juan have-SUBJ-3.SG read those books be-3.SG surprising
 ‘For John to have read those books is surprising’
- b. ?/??Es sorprendente el que Juan haya leído esos libros. (Spanish)
 be-3.SG surprising the that Juan have-SUBJ-3.SG read those books
 ‘It is surprising for John to have read those books’

As (48) shows, only the post-verbal clause allows extraction of the wh-object *qué libros* (Eng. *which books*):

(48)

- a. *[_{C*P} Qué libros_i C* es [_{TP} [_{C*P} que haya leído Juan t_i]_j T_S [t_j sorprendente]]]? (Spanish)
 what books be-3.SG that have-SUBJ-3.SG read Juan surprising
 ‘What books it is surprising for Juan to have read (them)?’
- b. [_{C*P} Qué libros_i C* es [_{SC} sorprendente [_{C*P} que haya leído Juan t_i]]]? (Spanish)
 what books be-3.SG surprising that have-SUBJ-3.SG read Juan
 ‘What books it is surprising for Juan to have read (them)?’

Interestingly, even post-verbal clauses block extraction if the article appears:

- (49) *[_{C*P} Qué libros_i C* es [_{SC} sorprendente [_{C*P} el que haya leído Juan t_i]]]? (Spanish)
 what books be-3.SG surprising the that have-SUBJ-3.SG read Juan
 ‘What books it is surprising for Juan to have read (them)?’

The same is observed with more complex patterns, like that in (50), where we have wh-sub-extraction from a wh-moved phrased in SPEC-C* (see section 4 for more discussion): the outcome is bad in both cases, but if the embedded interrogative clause has moved to a preverbal subject position, it is word-salad (hence the double star).

(50)

- a. * $[_{C^*P}$ De qué escritor_i C* te parece que $[_{TP}$ T_s es $[_{SC}$ increíble
of what writer CL-to-you seem-3.SG that be-3.SG incredible
... $[_{C^*P}$ [qué novelas t_i] C* han ganado premios]]]?
which novels have-3.PL won awards
‘Which writer does it seem to you that which novels by have won
awards is incredible?’
- b. ** $[_{C^*P}$ De qué escritor_i C* te parece que $[_{TP}$ $[_{C^*P}$ [qué novelas t_i]]_j C*
of what writer CL-to-you seem-3.SG that what novels
... t_j han ganado premios]_z T_s es $[_{SC}$ increíble t_z]]]? (Spanish)
have-3.PL won awards be-3.SG incredible
‘Which writer does it seem to you that which novels by have won
awards is incredible?’

The main goal of this section was to reinforce Boeckx’s (2003a) hypothesis that the *Subject Condition* is parasitic on Chomsky’s (2000b; 2001) *Activity Condition*, and not on structural factors concerning phase edges. I have drawn data from Dutch and Spanish showing that what matters for viable sub-extraction from subjects is the possibility for these DPs to remain *in situ*, circumventing de-activation. This possibility is normally barred in English (due to the effect of the EPP₂), which is why the *Subject Condition* holds in a pervasive way.

In line with Gallego & Uriagereka (2007), I have largely kept the implementation of the analysis to Boeckx’s (2003a) idea that the relevant freezing is connected to agreement features of subjects. However, as I said in section 1, it is odd to blame φ -features for islandhood, because they never delete: a more coherent explanation is that it is valuation of the T feature of DPs that renders them opaque. This is in accordance with the C/AoE:

(51) CASE/AGREEMENT CONDITION ON (SUB-)EXTRACTION (C/ACoE final version)

- a. A syntactic object whose φ -features can be matched is transparent
- b. φ -features of a syntactic object can be matched if it bears unvalued T

Hence, if a subject DP does not abandon SPEC- v^* , the T feature of the subject remains unvalued until the Transfer point: the DP is ‘active,’ and sub-extraction is possible. If the subject DP moves to SPEC- T_S , its T feature receives the nominative value at once: the DP is deactivated, and sub-extraction is barred.

Crucially, note that I must assume that valuation of subject’s T is obtained only if it is raised to SPEC- T_S , as it appears that C^* can target the subject in its base position, which suggests that C^* and T_S do not probe ‘in parallel,’ derivational steps being strictly cyclic: the subject first DP moves to SPEC- T_S , and then sub-extraction takes place.

I suggest that this SPEC- v^* vs. SPEC- T_S contrast with respect to Case is a side-effect of ‘maxima’ φ -checking taking place there (see Boeckx 2006a) –in a sense, then, I am relating Case checking to [person] checking through the SPEC of T_S .

(52) *Subject Condition qua Activity Condition*

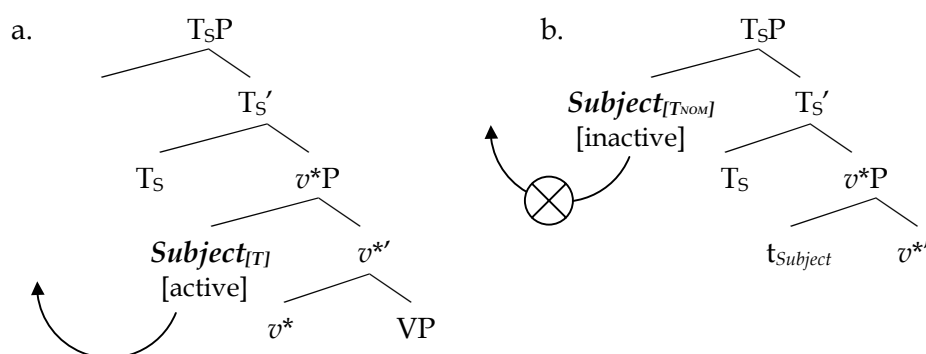

In the following subsection I reassess the data raised by Chomsky (to appear). If subject islandhood arises at SPEC- T_S , we must find out what factor Chomsky’s (to appear) contrast follow from.

3.2. Kuno’s (1973) Incomplete Constituent Effects

The last subsection was devoted to elaborate on Gallego & Uriagereka’s (2007) analysis of the *Subject Condition*, which concluded that *only SPEC- T_S blocks sub-extraction*. This, however, still raises the question of how come (18b), repeated below as

(53), is grammatical: assuming strict cyclicity, sub-extraction here should occur in SPEC-T_S, wrongly predicting an illicit output.

(53) [_{C*P} Of which car_i C* was [_{TP} [the driver t_j]_j T_S [_{vP} v awarded t_j a prize]]]?

Things become even more perplexing as soon as (54), from Chomsky (1995b: 328), is considered. The example is almost identical to (53) (except for pied-piping), but it is out.

(54) * [_{C*P} Who_i C* was [_{TP} [a picture of t_i]_z T_S [_{vP} v taken t_z by Bill]]]?



Attributing the original observation to Kuno (1973), Chomsky (1986a) notes that facts like (53) and (54) indicate that sub-extraction and pied-piping are somehow connected (see also Chomsky to appear: fn.38).¹⁷

Let us consider different pieces of evidence adduced in this regard, starting with (55). In these examples, both pied-piping and stranding yield a correct result.

(55)

a. [_{C*P} Who_i C* did Peter take [a picture of t_i]]?

b. [_{C*P} Of whom_i C* did Peter take [a picture t_i]]?

In turn compare (56) vis-à-vis (57) (only the latter pair taken from Kuno 1973), which suggest that sub-extraction from a displaced constituent is licit only if it involves pied-piping:

(56)

a. * [_{C*P} Who_i C* was [_{TP} [a picture of t_i]_z T_S taken t_z by Peter]]]?

b. [_{C*P} Of whom_i C* was [_{TP} [a picture t_i]_z T_S taken t_z by Peter]]]?

¹⁷ Chomsky (1986a: 32) suggests that the contrast might be due to the fact that PP-extraposition applies prior to wh-movement. See Hirata (1997) for discussion.

(57)

a. * $[_{C^*P}$ Which words_i C* is $[_{TP}$ [learning the spellings of t_i]_z T_S [_{SC} t_z difficult]]]?

b. ? $[_{C^*P}$ Of which words_i C* is $[_{TP}$ [learning the spellings t_i]_z T_S [_{SC} t_z difficult]]]?

[from Kuno 1973: 379]

(56) and (57) pose a very intriguing question: the position we identified as triggering freezing effects (namely, SPEC-T_S) actually seems to allow sub-extraction *when mediated via pied-piping*.¹⁸ The issue is how, of course.

In the 70s, Susumu Kuno argued for a solution that emphasized on the incomplete status of the domain from which sub-extraction takes place. That is, assuming DPs of the form [D [N of t]] are ‘incomplete,’ Kuno (1973) put forward the constraint in (58):

(58) **THE INCOMPLETE SUBJECT CONSTRAINT**

It is not possible to move any element of a subject noun phrase/clause if what is left over constitutes an incomplete noun phrase/clause

[from Kuno 1973: 380]

NP-incompleteness could be defined as follows:

(59) **NP INCOMPLETENESS**

A noun phrase/clause is incomplete if an obligatory element is missing. Thus, the [NP Prep] pattern is incomplete because the object of the preposition is missing

[from Kuno 1973: 380]

Unfortunately, it is not obvious how Kuno’s (1973) proposal could be formulated in current terms. To start with, it would be puzzling if ‘incompleteness,’ as defined in (59), imposed a constraint on sub-extraction.

Being deliberately naïve about it, it seems that displacement is the key when comparing (55) and (56)-(57): if a DP has moved to a freezing position, only pied-

¹⁸ These judgments are admittedly subtle. As Kuno (1973: 378) puts it: “[j]udgment of the degree of acceptability of [sub-extraction qua pied-piping] may differ from speaker to speaker, but it seems clear to all that [sub-extraction qua pied-piping] is considerably better than [sub-extraction without pied-piping].”

piping allows sub-extraction. But this is at odds with the very idea of freezing, since frozen DPs are islands, no matter what. Furthermore, pied-piping does not rescue the insular status of adjuncts, as (60) shows:

(60)

- a. * $[_{C^*P}$ Of which author_i C* did $[_{TP}$ John_j T_S $[_{v^*P}$ t_j call Mary [after he read the book t_i]]]?
- b. * $[_{C^*P}$ Which author_i C* did $[_{TP}$ John_j T_S $[_{v^*P}$ t_j call Mary [after he read the book of t_i]]]?

In order to solve the puzzle, in Gallego & Uriagereka (2007) we consider first why – in the specific case of Chomsky’s (to appear) example– *of which car* can be sub-extracted from a DP that has been displaced.

We know two things for sure: first, sub-extraction cannot have occurred from the final landing site, because of freezing; and, second, sub-extraction cannot have occurred from the base position either, since it would predict grammatical the stranding version (e.g., **Which car was the driver of awarded a prize?*), and this is contrary to fact.

The conclusion, as we underscore, is much in the spirit of Chomsky’s (to appear) analysis of sub-extraction from subjects in ECM and raising constructions: *sub-extraction occurs from an intermediate step* (signalled as *t* in 61 below) along the movement path of the phrase under investigation. Happily, this explains also why (18a) is out: since in this case *there is no intermediate position available* between the base and the final sites, sub-extraction is barred.

- (61) $[_{C^*P}$ Of which car_i C* was $[_{TP}$ [the driver of t_i]_Z T_S $[_{vP}$ t_Z $[_{vP}$ v awarded t_Z a prize]]]
- ↓
sub-extraction takes place HERE

In a nutshell, Gallego & Uriagereka (2007) assume that, in (61), sub-extraction of *of which car* takes place from SPEC-*v*, an intermediate landing side (i.e., neither the base nor the final one).

An appealing advantage of this solution is that it appears to fit with the observation by Postal (1974) that stranding is disallowed in intermediate positions:

(62)

- a. [_{C*P} Who_i C* do you think [_{C*P} (that) John talked [_{PP} to t_i]]]?
 b. * [_{C*P} Who_i C* do you think [_{C*P} [_{PP} to t_i]_z (that) John talked t_z]]?

Having explored sub-extraction patterns from subjects (EAs), I turn my attention to a second kind of dependent that may end up occupying SPEC-*v**: shifted objects. Once again, I will base my discussion on the analysis put forward by Gallego & Uriagereka (2007; to appear):

3.3. Sub-extraction from Shifted and Agreeing Objects

In this section I explore the consequences of a C/ACoE-based approach to sub-extraction from objects. As noted in section 2, these dependents (contrary to subjects and adjuncts) typically behave as transparent domains:¹⁹

(63)

- a. [_{C*P} What_i C* do you want to see *v** [a picture of t_i]]?
 b. [_{C*P} What_i C* do you want to see *v** [pictures of t_i]]?
 c. [_{C*P} What_i C* do you want to see *v** [some pictures of t_i]]?

[from Boeckx 2003a: 106]

As noted in section 3.1., sub-extraction from objects is possible in Spanish as well:

- (64) [_{C*P} De qué lingüista_i C* vais a leer [_{v*P} *pro v** [muchos artículos t_i]]]? (Spanish)
 of what linguist go-2.PL to read-INF many papers
 ‘Which linguist are you going to read many papers by?’

¹⁹ As is well-known since Chomsky (1973), specific objects block sub-extraction:

- (i) * [_{C*P} What_i C* do you want to see *v** [a given picture of t_i]]?
 (ii) * [_{C*P} What_i C* do you want to see *v** [these pictures of t_i]]?
 (iii) (*) [_{C*P} What_i C* do you want to see *v** [the picture(s) of t_i]]?

[from Boeckx 2003a: 106]

Here I do not investigate the factor responsible for this interpretive effect, nor its implications for sub-extraction. See Boeckx (2003a), Mahajan (1992), Ormazabal (1992), Stepanov (2001), and Uriagereka (1993) for different analyses of the *Specificity Condition*.

Given the nature of our discussion what is relevant here is whether objects end up occupying a phase edge, hence undergoing a raising process to an outer-SPEC-*v**. Chomsky’s position has gone back-and-forth in this respect, but none of his minimalist accounts assumes overt object raising in English: in Chomsky (1995b) objects are said to raise to SPEC-*v** in the covert component,²⁰ whereas Chomsky (2000; 2001) appeals to long-distance Agree. If objects do not overtly shift to SPEC-*v**, Gallego & Uriagereka’s (2007) *Edge Condition* cannot be tested.

However, as an alternative to Chomsky’s (1995b; 2000; 2001) analyses, several researchers (most notably, Johnson 1991, Koizumi 1995, and Lasnik 1999b; 2001a; 2002) have argued that English objects do undergo overt raising. Importantly, for these scholars object raising targets a position below the EA, hence not a phase edge.²¹

Lasnik (1999b; 2001a; 2002), for instance, takes SPEC-Agr_O to be the landing site of objects:²²

(65) [_{VP} Subject V [_{Agr-oP} Object_i Agr_O [_{VP} V t_i]]]

[from Lasnik 1999b: 147]

Adapted to our system, Lasnik’s (1999b; 2001a; 2002) SPEC-Agr_O can be identified with Pesetsky & Torrego’s (2004) SPEC-T_O. It is important to highlight, as Lasnik (1999b; 2001a; 2002) does, that this projection is a lower counterpart of SPEC-T_S: hence, if the latter triggers a freezing effect, the former must do so too.

Lasnik and Saito (1999) and Lasnik (1999b; 2001a; 2002) provide ample empirical evidence that objects optionally raise to a Case checking position internal to the *v**P in

²⁰ Chomsky’s (1995b) analysis is a reformulation of Chomsky’s (1993a), where objects move to a dedicated agreement projection above the subject.

²¹ See Stepanov (2001) for a different analysis. According to him, object raising is restricted to specific objects, which move to SPEC-*v** (not SPEC-V or SPEC-Agr_O).

²² Chomsky (2007) adopts this analysis, rephrasing it so that objects raise to SPEC-V. As Cedric Boeckx points out through personal communication, object raising cannot target SPEC-V, due to anti-locality reasons (see Abels 2003). That entails that an additional projection is needed –for instance, Pesetsky & Torrego’s (2004) SPEC-T_O or Lasnik’s (1999a; 2001a) SPEC-Agr_O.

English.²³ Consider, first, anaphoric binding (66a) and NPI licensing (66b) in ECM environments:

(66)

- a. [_{C*P} C* [_{TP} The DA proved *v** [two men_i [_{TP} t_i to have been t_i at the scene of crime]] . . .
 . . . during **each other**_i's trials]
- b. [_{C*P} C* [_{TP} The DA proved *v** [none_i [_{TP} t_i to have been t_i at the scene of crime]] . . .
 . . . during **any** of the trials]

[from Lasnik 2001a: 103-104]

A second argument comes from pseudogapping, which Lasnik (1999b; 2001a) analyzes as a VP segment deletion, preceded by obligatory object raising:

(67) Mary hired John, and [_{TP} Susan_j T_S will [_{v*P} t_j *v** [_{AgroP} Bill_i Agro [_{VP} ~~hire t_i~~]]]]

[from Lasnik 2001a: 107]

A third argument is provided by verb-particle constructions. Following Johnson (1991), Lasnik (2001a) takes the V-DP-Prt order to follow from objects escaping from their base position:

(68)

- a. [_{C*P} C* [_{TP} Mary_i T_S [_{v*P} t_i *v** called up [friends of John]]]]
- b. ?[_{C*P} C* [_{TP} Mary_i T_S [_{v*P} t_i *v** called [friends of John]_i up t_i]]]

[from Lasnik 2001a: 111]

Most relevantly, as Lasnik (2001a) observes, sub-extraction from shifted objects is severely degraded:

(69)

- a. [_{C*P} Who_i C* did Mary *v** call up [friends of t_i]]?
- b. ?*[_{C*P} Who_i C* did Mary *v** call [friends of t_i]_j up t_j]]?

[from Lasnik 2001a: 111]

²³ Optionality depends on specific properties of the phenomena under consideration: pseudogapping, for instance, forces raising, while ECM does not.

The same facts are noted by Kayne (2002) (see Kayne 2000: chapter 13):

(70)

- a. Tell me [_{C*P} who_i C* you're v* touching up [a picture of t_i]]?
 b. ??Tell me [_{C*P} who_i C* you're v* touching [a picture of t_i] up t_j]

[from Kayne 2002: 74]

As (71) and (72) show, sub-extraction is also barred in both pseudogapping and ECM contexts. Notice that, in these cases, raising must have taken place.

(71) ?*[_{C*P} Who_j C* will Bill v* select [a painting of t_j]], and . . .

. . . [who_i C will Susan [[a photograph of t_i]_z v* [~~select t_z~~]]]

[from Lasnik 2001a: 110]

The case of ECMs is particularly telling, as it reinforces the hypothesis that Case checking positions are the ones rendering DPs opaque. This can be seen in (72), where sub-extraction is always ruled out, since even if the object does not raise into the matrix clause (see 72b), it does into the embedded subject position: SPEC-T_{φ-def}.²⁴

(72)

- a. ?*[_{C*P} Who_i C* did Mary [_{v*P} v* make [friends of t_i]_j out [TP t_j to be t_j fools]]]]
 b. ?*[_{C*P} Who_i C* did Mary [_{v*P} v* make out [TP [friends of t_i]_j to be t_j fools]]]]

[from Lasnik 2001a: 112]

Summarizing, Lasnik's (1999a; 2001a; 2002) findings convincingly show that *objects optionally shift to a φ-freezing position within the v*P phase: crucially, that position does not coincide with an edge, but with a lower, Case related, specifier*. It is therefore important to highlight that the data just reviewed, as such, do not go against Chomsky's (to appear) claims (since object raising does not target phase edges to begin with), but it does reinforce an *Activity Condition* based analysis of sub-extraction.

²⁴ The datum in (72b) is at odds with the facts in (14), where sub-extraction out of subjects was argued to take place from the specifier of φ-defective T_S (ECM and raising). I believe, however, that (72) has an additional interfering factor: the 'incomplete constituent' effects of Kuno (1973). See previous section.

To end this section, I would like return to Spanish, which, as argued in chapter 3, it also manifests a variety of *Object Shift*. In particular, as argued by Ordóñez (1998b), VOS sequences in Spanish are created by means of object scrambling across the subject. That this analysis is the correct one in Spanish (but perhaps not in Catalan and Italian; see Belletti 2004) can be shown by the binding effect in (73), taken from Ordóñez (2005):

- (73) Ayer visitó a cada chico_i su_i mentor. (Spanish)
 yesterday visit-PAST-3.SG to each boy his mentor
 ‘His mentor visited each boy yesterday’

[from Ordóñez 2005: 45]

Surprisingly, object movement appears to be orthogonal to sub-extraction in Spanish: even in its derived position, objects are ‘transparent:’

- (74)
 a. [_{C*P} De qué escritor_i C* ha comprado [_{v*P} María v* [dos libros t_i]]]? (Spanish)
 of what writer have-3.SG bought María two books
 ‘Which writer has María bought two books by?’
 b. [_{C*P} De qué escritor_i C* ha comprado [_{v*P} [dos libros t_i]_j [_{v*P} María v* t_j]]]? (Spanish)
 of what writer have-3.SG bought two books María
 ‘Which writer has María bought two books by?’

The unexpected case is (74b): why does moving *dos libros de qué escritor* (Eng. *two books of which writer*) yield no freezing effect? Perhaps the lack of overt object agreement in Spanish is responsible for this.

In stark contrast, Basque, which has overt object agreement, does block sub-extraction, as noted by Uriagereka (1988a; 2004) following an observation of Patxi Goenaga’s:

- (75) * [_{C*P} Noren_i C* ikusi ditu [_{v*P} [t_i argazkiak]_j [Jon_ek v* t_j]]]? (Basque)
 who-GEN see-INF 3.PL-AUX-3.SG pictures-ABS Jon-ERG
 ‘Who has Jon seen pictures of?’

[from Uriagereka 2004: 18]

English, though, still remains problematic: this language lacks overt object agreement (even if the relevant dependents move to *AgroP*), and it blocks sub-extraction regardless.

But perhaps this is too hasty a conclusion. Spanish actually has some form of object agreement, though disguised in clitic fashion (see Torrego 1995a; 1998a and Solà 2002). In this vein, it is interesting to note that in so-called clitic doubling contexts, the double (pleonastic) DP must be introduced by a Case marker –in accord with *Kayne’s Generalization* (see Kayne 1975; 1991; 2000). This is shown by the data in (76), where the clitics *lo* (Eng. *him*-ACC) and *le* (Eng. *him/her*-DAT) are doubled by *él* (Eng. *he*) and *María*, both of which must be introduced by the dative preposition *a*:

(76)

a. Lo vimos *(a) él. (Spanish)

CL-him see-PAST-1.PL to him

‘We saw him’

b. Le dimos el libro *(a) María. (Spanish)

CL-to-him give-PAST-1.PL the book to María

‘We gave the book to María’

[from Gallego & Uriagereka to appear: 12]

If object clitics (whether they are actually pronounced or not) somehow count as agreement morphemes attached to the verb, then a rationale emerges for why both Case marked direct objects (77a and 77b) and indirect objects (77b) are islands:

(77)

a. *[_{C*P} De quién_i C* has visitado [_{v*P} *pro* v* [a muchos amigos t_i]]]? (Spanish)

of whom have-2.SG visited pro to many friends

‘Who have you visited many friends of?’

b. *[_{C*P} De qué estudiante_i C* has criticado [_{v*P} *pro* v* [a los padres t_i]]]? (Spanish)

of what student have-2.SG criticized pro to the parents

‘Which student have you criticized the parents of?’

- c. *_{[C*P} De quién_i C* le diste [_{v*P} *pro v** los libros [a los padres <sub>t_i]]]? (Spanish)
of whom CL-to-him give-PAST-2.SG pro the books to the parents
‘Who did you give the books to the parents of?’</sub>

Things could actually become trickier here, for Spanish Case marked objects have been analyzed as occupying a *v*P* specifier (see Torrego 1998a), a possibility that brings the role of the *Edge Condition* back to the fore.

Be that as it may, it is not obvious how the same logic could be pushed to account for indirect objects, which are generally analyzed as dependents of applicative heads (see Jeong 2007 for recent discussion). A more plausible and unifying way to go about the facts in (77) would simply take Case (more precisely, the *lack of unvalued T*) to be responsible for the island status of Spanish Case marked DPs.

As we note in Gallego & Uriagereka (2007; to appear), this conclusion is supported by the so-called impersonal/passive alternation involving the clitic *se* in Spanish (see Raposo & Uriagereka 1996). In (78a), which features a “passive-*se*,” the verb overtly agrees with the object DP *los cuadros* (Eng. *the paintings*). Importantly, the “impersonal-*se*” in (78b) involves a Case marked object, which blocks verb-object agreement:²⁵

- (78)
- a. Se limpiaron los cuadros. PASSIVE SE (Spanish)
CL-SE clean-PAST-3.PL the paintings
‘Paintings were cleaned up (by someone)’
- b. Se limpió a los chicos. IMPERSONAL SE (Spanish)
CL-SE clean-PAST-3.SG to the children
‘The children were cleaned up (by someone)’

[from Gallego & Uriagereka to appear: 13]

As indicated by traditional grammarians, “passive-*se*” and “impersonal-*se*” are plausibly related: in both cases, the clitic *se* blocks the presence of the EA, forcing the

²⁵ In (78) I choose a verb in which Case marking is optional (*limpiar* – Eng. *clean*), but I hasten to add that this particular phenomenon depends on many different factors (e.g., specificity, affectedness, stativity, animacy, etc.; see Torrego 1998a). It is beyond the scope of this thesis to address what factors govern object Case marking in Spanish.

verb to agree with the object. Now, if the object ends up being Case marked by the preposition *a*, as in (78b), agreement is blocked and sub-extraction becomes impossible:

(79)

- a. (?)_{[C*P De qué artistas_i C* se_j limpiaron ya [_{v*P t_j v*} [los cuadros t_i]]]?} (Spanish)
of what artists CL-SE clean-PAST-3.PL already the paintings
‘Which artists were the paintings by already cleaned up (by someone)?’
- b. *_{[C*P De qué padres_i C* se_j limpió ya [_{v*P t_j v*} [a los hijos t_i]]]?} (Spanish)
of what parents CL-SE clean-PAST-3.PL already to the children
‘Which parents were the children of already cleaned up (by someone)?’

Consider, for the punch line, the following paradigm, due to Torrego (1998a):

(80)

- a. El chico _{[C*P del que_i C* he visto [varias hermanas t_i] ayer]} (Spanish)
the boy of-the which have-1.SG seen several sisters yesterday
‘The boy of whom I have seen several sisters yesterday’
- b. ?El chico _{[C*P del que_i C* han visto [a varias hermanas t_i] ayer]} (Spanish)
the boy of-the which have-3.PL seen to several sisters yesterday
‘The boy of whom they have seen several sisters yesterday’
- c. *El chico _{[C*P del que_i han acusado [a una hermana t_i]]} (Spanish)
the boy of-the which have-3.PL accused to a sister
‘The boy of whom they have accused one sister’

[from Torrego 1998a: 37-38]

The contrast between (80b) and (80c) is subtle and slightly problematic: since both DPs bear the Case marker *a*, it is not easy to see why sub-extraction is worse in the latter example.

Torrego (1998a: 38) accounts for the asymmetry by arguing that the ‘affected’ object in (80c) receives *inherent accusative Case* (standard datives would always involve inherent Case, as indicated by the directional semantics of the preposition). Torrego’s (1998a) idea can possibly be recast by positing a more complex structure to verbs

assigning inherent accusative, such as *acusar* (Eng. *accuse*). In particular, I want to propose the structure in (81b) to capture the particular semantics of this verb:

(81)

- a. [_{v*P} v* [_{VP} EA V see [_{DP} several sisters of whom]]
 b. [_{v*P} v* [_{VP} EA V *provide* [_{PP} several sisters of whom [_P P *with* √*accusation*]]

The structure in (81b) tries to embody the idea that inherent accusative depends on a more complex structure, where the object starts being the complex specifier of a small clause selected by the light verb *provide*, just like in the analysis of locatum verbs put forward by Hale & Keyser (2002). As for structural accusative, (81) claims it is assigned to objects which are base generated as direct dependents of the verb.²⁶

An analysis along these lines might shed some light as to why sub-extraction from both objects with inherent accusative Case and DPs that receive oblique Case (e.g. datives and some adjuncts), is entirely impossible: if the preposition that appears in the case of structural accusative does not label the object DP, we may have an explanation for why sub-extraction, though degraded, is still possible (see section 5 for additional discussion).

The idea I am trying to express is that the *a* of structural accusative does not give rise to a PP: the *a* of inherent accusative does, just like the *a* of datives and all prepositions heading adjuncts. This idea was already presented in chapter 3, which I repeat here:²⁷

(82)

- a. [_{DP} *a* D NP] *structural accusative "a"*
 b. [_{PP} P *a* [D NP]] *inherent accusative (and dative) "a"*

²⁶ This raises many questions, starting with how the *structural* vs. *inherent* distinction is to be understood within minimalism, particularly so if S-Structure and D-Structure representations are dispensed with.

²⁷ See Stepanov (2002) for related ideas with respect to inherent Case. In his account, Stepanov (2002) relates the impossibility of these dependents to agree to late insertion: the DP bearing inherent Case is inserted postcyclically and cannot establish Agree. As can be seen, Stepanov (2002) treats such DPs as structural adjuncts: this is formally different from my proposal, but it also relates DPs receiving inherent (for me, *oblique*) Case with adjuncts in that both are opaque.

If the structures in (82) are correct then the C/ACoE can explain why sub-extraction is much worse with Goals that have the shape of (82b): *valued T act as syntactic shields, making DPs ‘ φ -Probe-proof.’*

Of particular relevance for the asymmetry in (82) is the fact that while agreement with Case marked objects is degraded in Spanish, it is better than agreement with datives:²⁸

(83)

a. ??/*Se vieron a los estudiantes. (Spanish)

CL-SE see-PAST-3.PL to the students

‘The students were seen’

b. **Se dieron la noticia a los estudiantes. (Spanish)

CL-SE give-PAST-3.PL the news to the students

‘The students were given the news’

c. **Se dieron consejo a los niños. (Spanish)

CL-SE give-PAST-3.PL advice to the boys

‘Advice was given to the boys’

Actually, Torrego (1995a) herself notes that Case marked objects can agree with participles:

(84) Tengo a mis hijas castigadas. (Spanish)

have-1.SG to mi daughters-FEM-PL punished-FEM-PL

‘I have my daughters punished’

Crucially, this participial agreement is out with regular datives.

(85) *Tengo a mis hijas dadas muchos libros. (Spanish)

have-1.SG to my daughters given-FEM.PL many books

‘I have my daughters given many books’

²⁸ As Paco Ordóñez observes through personal communication, it is rather usual that verb-object agreement takes place with Case marked objects in the Spanish variety spoken in Mexico.

Likewise, it is impossible for T_S to establish Agree with DPs within adjuncts. Under the system I am outlining here, this follows from the preposition creating a syntactic barrier (see section 5):

(86)

- a. *Cantamos Juan [_{PP} P para [_{DP} los niños]] (Spanish)
 sing-1.PL Juan for the kids
 ‘Juan sing for the kids’
- b. *Se pintaron el cuadro [_{PP} P por [_{DP} los artistas]] (Spanish)
 CL-SE paint-3.PL the painting by the artists
 ‘The painting were painted by the artists’

I take these facts to reinforce the role played by the C/ACoE: *if a SO is inactive (either because its Case has been checked or else because it is introduced by a ‘projecting’ preposition), sub-extraction is impossible.* This is all we need to explain why sub-extraction is impossible out of datives, adjuncts, and inherent Case marked accusatives –and degraded from within structural Case marked accusatives.²⁹

²⁹ Chomsky (1986a) mentions the pair in (i) and (ii) to show that sub-extraction from adjuncts also shows a Kuno-like effect:

- (i) [_{C^P} To whom_i C* did they leave before speaking t_i]?
 (ii) [_{C^P} Who_i C* did they leave [before speaking to t_i]] (before meeting t_i)?
 [from Chomsky 1986a: 31]

In Chomsky (1986a), one can read the following:

Adriana Belletti has pointed out that [ii] is a less severe violation than [i], a distinction that some speakers find clearer in the corresponding relatives: *He is the person to whom they left before speaking* [and] *He is the person who they left before speaking to before meeting.*
 [from Chomsky 1986a: 32]

The examples in (i) and (ii) are not, strictly speaking, cases of sub-extraction from adjuncts, but parasitic gaps. Putting aside the effect of stranding, sub-extraction takes place from a gerund clause, which is normally translated as an infinitive (or a subjunctive) in Spanish. With this in mind, consider the data in (iii), (iv), and (v), taken from Gallego (2006c) –as can be seen, the same effect obtains:

- (iii) * [_{C^P} Qué libro_i C* compraste t_i [_{porP} porque Juan leyó t_i]]? (Spanish)
 what book buy-PAST-2.SG for-that Juan read-PAST-3.SG
 ‘What book did you buy because Juan read?’
- (iv) [_{C^P} Qué libro_i C* compraste t_i [_{paraP} para que Juan leyese t_i]]? (Spanish)
 what book buy-2.SG to that Juan read-SUBJ-3.SG
 ‘What book did you buy for Juan to read?’
- (v) [_{C^P} Qué libro_i C* compraste t_i [_{paraP} para leer t_i]]? (Spanish)
 what book buy-PAST-2.SG to to-read

The conclusion is compatible with the English facts: frozen objects are islands, and, as (87) indicates, datives are too –regardless of whether pied-piping is invoked or not.

(87)

- a. *_[C*P] Of who_i C* did you send presents [_{PP} to friends t_i]]?
- b. *_[C*P] Who_i C* did you send presents [_{PP} to friends of t_i]]?

In the following two sections I want to explore the syntactic dependency established between verbs, embedded C*Ps (when developing an object role), and PPs.

4. The C/ACoE and C*P Dependents

In what follows I consider the empirical coverage of the C/ACoE with respect to clausal dependents: C*Ps in object position. Following the system put forward in chapter 2, I assume that both D and C* have the featural specification indicated in (88) (see Pesetsky & Torrego 2001 and Szabolcsi 1992):

(88) *Composition of C* and D*

- a. ϕ -features
- b. Case (T) feature

At this point I would like to go back to Rackowski & Richard’s (2005) proposal, mentioned in section 1. Recall that the key of their account is that v^* must establish Agree with C* for the latter to become transparent. Although these scholars are not very precise in the formulation of such a process, they do argue that the relevant feature is Case: v^* and C* undergo Agree, and Case morphology shows up in the verb.³⁰

‘What book did you buy to read?’

See section 5 for additional discussion about sub-extraction from adjuncts.

³⁰ Rackowski & Richards (2005: 583) actually endorse the idea that C* and D “have similar requirements with respect to Case.” I would like to reinterpret this by taking C* and D to both bear T.

As Rackowski & Richards (2005) show, Agree operates the same way, regardless of whether the relevant argument of the verb is a DP or a C*P. This can be seen in (89) and (90), where Case morphology appears in **boldface letter** and the agreeing dependents in *italics*.³¹

(89) *Agree (v*, DP)*

a. **N-agbigay** *ang magsasaka* ng bulaklak sa kalabaw. (Tagalog)

NOM.ASP-give ANG farmer CS flower DAT water.buffalo

‘The farmer gave a flower to the water buffalo’

b. **I-b-in-igay** ng magsasaka *ang bulaklak* sa kalabaw. (Tagalog)

OBL-ASP-give CS farmer ANG flower DAT water.buffalo

‘A/The farmer gave the flower to the water buffalo’

c. **B-in-igay-an** ng magsasaka ng bulaklak *ang kalabaw*. (Tagalog)

ASP-give-DAT CS farmer CS flower ANG water.buffalo

‘A/The farmer gave a/the flower to the water buffalo’

[from Rackowski & Richards 2005: 585]

(90) *Agree (v*, C*P)*

Sa-sabih-in ng kalabaw [_{C*P} C* *na masarap ang bulaklak*] (Tagalog)

ASP-say-ACC CS water.buffalo that delicious ANG flower

‘A/The water buffalo will say that the flower is delicious’

[from Rackowski & Richards 2005: 586]

Also importantly: no matter what the Case value of C* turns out to be, *v** must agree with it. In (91) below, each verb imposes different Case constraints on the C*P it subcategorizes, so different T values show up on *v**:

(91) *Agree (v*, C*P)*

a. Kailan [sa-sabih-**in** ng sundalo [*na Ø-u-uwi ang pangulo e*]]? (Tagalog)

when **ASP-say-ACC** CS soldier that **NOM-ASP-go.home** ANG president

‘When will the soldier say that the president will go home?’

³¹ Recall that the Tagalog *ang*-marker is related to a semantic effect –usually, specificity.

- b. Kailan [i-p-inangako ng sundalo [na Ø-u-uwi ang pangulo e]]? (Tagalog)
when OBL-ASP-promise CS soldier that NOM-ASP-go.home ANG president
'When did the soldier promise that the president would go home?'
- c. Kailan [i-in-aniwala-an ng sundalo [na Ø-u-uwi ang pangulo e]]? (Tagalog)
when ASP-believe-DAT CS soldier that NOM-ASP-go.home ANG president
'When did the soldier believe that the president would go home?'

[from Rackowski & Richards 2005: 586]

If we try to translate this into the system I have been assuming all along, we reach a conclusion which is compatible with Pesetsky & Torrego's (2004) claim about the nature of complements of verbal T_0 :

(92) *Special property of (verbal) T_0*

The Goal of T's φ -Probe must bear unvalued T

[from Pesetsky & Torrego 2004: 511]

Recall that (92) was motivated by facts like (93):

(93)

- a. John fears the dark.
b. *John fears of the dark.

[from Pesetsky & Torrego 2004: 511]

Within the proposal put forward here, it is unvalued T that makes the φ -bundle of the object DP visible (i.e., 'matchable') to the φ -Probe of v^* - T_0 -V complex. Let us then assume that the process of sub-extracting from a C*P/DP involves a complex Agree procedure: first, the v^* - T_0 -V complex launches its φ -Probe in order to match that of the object C*P/DP; second, only if the latter bears unvalued T will matching succeed, and sub-extraction will be granted; third, the v^* - T_0 -V complex assigns a value to the T feature of the C*P/DP, which is rendered opaque from that moment on.

The mentioned steps seem to be coherent, but a problem remains. As we have seen, the key for C*P/DPs to be transparent is to bear unvalued T. This is straightforward in the case of DPs, whose T-feature is valued by T_0 's, but things are not so clear when one

looks at C*Ps, because their T has been deleted in the previous phase (by means of some clause internal C*-T dependency; see chapter 2).³² The problematic asymmetry is illustrated in (94) and (95):

(94) *Agree* (v^* - T_O - V , DP)

$[_{v^*P} v^*-T_O-V_{[T_{ACC}]}]_{[\varphi]} [DP D_{[T]} [2.SG]} \dots]]$ *D has unvalued T*

(95) *Agree* (v^* - T_O - V , C^*P)

$[_{v^*P} v^*-T_O-V_{[T_{ACC}]}]_{[\varphi]} [C^*P C^*_{[T_{NOM}]} [3.SG]} \dots]]$ *C* lacks unvalued T*

The asymmetry between (94) and (95) concerns the way C* and D delete their T features within Pesetsky & Torrego's (2001; 2004; 2006; 2007) system: D needs external help (the verb assigns Case), while C* can do it within its own projection (T_s does the job). If this is so, then C*Ps should have no T-feature for higher v^*/T_O to agree with, which is at odds with (92). In this regard, Pesetsky & Torrego (2004) make the following observation:

As long as uT on C is undeleted at the stage in the derivation at which $u\varphi$ on T_O acts as a probe, [92] will be satisfied [...] in [a configuration like *I said Mary left*] the uT feature on C, marked for deletion by the nominative DP that moves to Spec-CP, must still be present at the point in the derivation at which $u\varphi$ on T_O probes the CP complement of V. [from Pesetsky & Torrego 2004: 516 –emphasis added, AJG]

In short, Pesetsky & Torrego (2004) suggest that the T feature of an object C*P must remain unvalued in the higher phase, but this is incompatible with standard assumptions about cyclic deletion (the *Phase Condition* of chapter 2).

Notice that the problem extends to C*'s φ -features, as these should delete by the end of the C*P phase too.

For consistency, I will continue to assume that both T and φ -features on C* can be valued internally to the C*P, and that they delete by the time the C*P is transferred. Now, in order to get around the problem that arises as soon any higher Probe wants to establish Agree with a dependent C*P, I assume (inspired by ideas of Abels 2003,

³² I am assuming that deletion processes do not operate in the same way in DPs and C*Ps, in accordance with what Pesetsky & Torrego (2001; 2004; 2006; 2007) claim.

Boeckx 2006b, and Picallo 2002) that the φ -Probe launched by higher T_O can be valued by (receiving a) default (value) (see, in particular, Abels 2003: 53 and ff.).

This cannot be tested in the case of complement clauses in languages like Spanish, but Picallo (2002) provides the relevant evidence in the case of subject C*Ps. As she shows, subject C*Ps, even if coordinated, always show default, [person: 3] [number: SG], agreement:

(96)

- a. Es necesario [C*P C* que hablemos un rato] (Spanish)
 be-3.SG necessary-MASC.SG that talk-SUBJ-1.PL a while
 ‘It is necessary for us to talk for a while’
- b. {Es/*Son} necesario{-Ø/*-s} [C*P C* que hablemos un rato] ... (Spanish)
 be-3.{SG/PL} necessary-MASC.{SG/PL} that talk-SUBJ-1.PL a while
 ... y [C*P C* que nos pongamos de acuerdo]
 and that CL-us put-1.PL of agreement
 ‘It is necessary for us to talk for a while and for us to agree’

[from Picallo 2002: 117]

Picallo (2002) claims that the φ -specification of C* is negative: [-P, -G, -N]. For reasons I have already mentioned, I cannot follow Picallo (2002). However, I want to recruit her claim by assuming that deletion of C*'s φ -features in the C*P phase are responsible for default agreement.

As for C*'s T feature, there is no much room to manoeuvre: I also take it that it is deleted within the C*P. The question is whether this deletion causes a crash at a subsequent derivational stage. We have already seen that there is no crash, which I take to indicate that the system must make use of some last resort strategy to satisfy (92). One way to go about this puzzle is to say that for both (92) and the C/ACoE to be satisfied *it suffices if embedded C*P does not bear valued T*. In other words: I am assuming that the system can get around this conundrum as far as no P/T element is heading the C*P. Since such an undesired scenario only arises with adjunct clauses in my proposal (see 97b), the correct predictions are made.

(97)

- a. [_{v*P} v*-T_O-V_[TACC] [_φ] [_{C*P} C*_{[FNOM][2.SG]} . . .]] *complement clause (C* lacks unvalued T)*
- b. * [_{v*P} v*-T_O-V_[TACC] [_φ] [_{PP} P_[TOBL] [_{C*P} C*_{[FNOM][2.SG]} . . .]]] *adjunct clause (C* has valued T)*

A residual problematic case concerns embedded C*Ps introduced by *that*, which is an instance of *valued T* in Pesetsky & Torrego (2001). The prediction is then that *that*-dependents should also be opaque, which is clearly not correct. To avoid this problem, I want to emphasize the idea (sketched in chapter 2) that T-to-C movement gives rise to a hybrid label –given the dual nature of the label, the C*P cannot be said to be introduced by valued T entirely.

Summing up, the essence of the C/ACoE extends to clausal dependents: these allow sub-extraction as long as they are not introduced by valued T (a preposition) or moved to a position triggering full ϕ -feature checking (see section 3.1.).

5. Some Observations about PPs: Consequences for the Argument/Adjunct Distinction and Prepositional *Phase Sliding*

Building on Pesetsky & Torrego (2004) and their (92) I have been assuming that PPs are adjuncts of sorts.³³ Such an assumption, however, is not standardly entertained, since many types of PPs are said to be s-selected by verbs. Some such cases are mentioned by Pesetsky & Torrego (2004):

(98)

- a. [_{v*P} This issue v* matters [_{TP} T_O[_{TACC}] [_{PP} P_[TOBL] *to* Sue]]]
- b. [_{v*P} The dogs v* barked [_{TP} T_O[_{TACC}] [_{PP} P_[TOBL] *at* the mailman]]]
- c. [_{v*P} We v* spoke [_{TP} T_O[_{TACC}] [_{PP} P_[TOBL] *to* the president]]]]
- d. [_{v*P} Bill v* looked [_{TP} T_O[_{TACC}] [_{PP} P_[TOBL] *at* the statue]]]

[from Pesetsky & Torrego 2004: 513]

³³ Putting forward a comprehensive proposal with respect the argument vs. adjunct distinction goes beyond my aim. Nevertheless, and given that my analysis of sub-extraction has some bearing on the strong island nature of PPs, some comments are in order.

In order to make the data in (98) compatible with (92), Pesetsky & Torrego (2004) argue that these PPs must be analyzed as (concealed) second objects, under the assumption that true first objects have been either promoted to the subject position or incorporated into the verb.³⁴

In this thesis, I tentatively stick to (92) as a formal criterion to define ‘argumenthood.’ More radically, I propose to modify (92) as (99):

(99) **ARGUMENT VS. ADJUNCT DISTINCTION**

- a. Arguments bear unvalued T
- b. Adjuncts/Modifiers bear valued T (i.e., prepositions)

As intended, the logic in (99) is consistent with the PP dependents in (98) being not arguments, but adjuncts of sorts.

More cases challenging (92) have been reported in the literature, consider some of them in turn. Locative PPs in locatum/location predicates (100), Case marked direct objects (101), dequeísta C*Ps (102), and so-called governed prepositional objects (103), are usually taken to be arguments.

(100) John put the books on the shelf.

(101) Ana saludó a un amigo. (Spanish)
Ana greet-PAST-3.SG to a friend
‘Ana greeted a friend’

(102) Pienso de que los conozco poco. (D. Spanish)
think-1.SG of that CL-them know-1.SG few
‘I think I do not know them much’

³⁴ Pesetsky & Torrego (2004) end their reasoning as follows:

[I]f it should turn out that some PPs are genuine first objects of verbs, *we might propose that satisfaction of the selectional properties of a verb takes priority over satisfaction of [92] –in other words, that a violation of [92] by a goal that bears iT for selectional reasons is permitted.*
[from Pesetsky & Torrego 2004: 514 –emphasis added, AJG]

- (103) Esta autora discrepa de mis opiniones. (Spanish)
 this author disagree-3.SG of my opinions
 ‘This author disagrees with my opinions’

Consider locative PPs first. Hale & Keyser (2002: 94-98) argue that location and locatum verbs take the complement of P as their direct dependent: this is so –Hale & Keyser (2002) suggest– because they are the elements that end up incorporating into the verb, as indicated in (104):

- (104) $[_{C^*P} C^* [_{TP} John_i T_S [_{v^*P} t_i v^* [_{VP} put [_{PP} the\ books [_{P'} P\ on\ \check{v}shelf]]]]]]]$
-

At first glance, though, this claim is not so obvious. For one, it is not entirely clear how the would-be object ($\check{v}shelf$, in 104) is not directly merged with the verb, being generated as P’s direct dependent, instead. Second, a strict interpretation of (92) actually makes the opposite prediction: it is the DP *the books* that the verb selects as its direct dependent, for it is this DP that receives accusative Case.

In order to stick to (92), it could be argued that (104) is not analyzed as (105a), but as (105b), contrary to Hale & Keyser’s (2002) proposal. Such a move is worrisome, for the structure does not capture the relevant Figure-Ground semantics between *the books* and *shelf*.

- (105)
- a.

b.

Adopting ideas that were presented in chapters 1 and 3, I would like to argue that the syntactic object undergoing external Merge with *put* is not labeled:

(106)

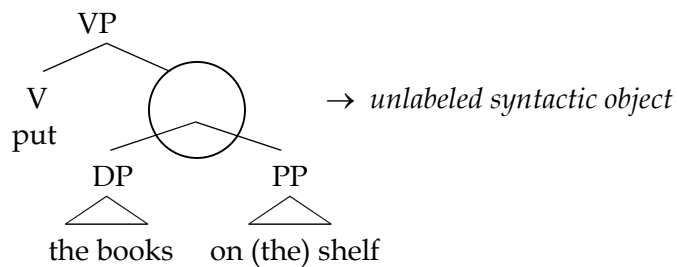

If this possibility is tenable, then (92) need not be abandoned. Consider now the cases in (102) and (103).³⁵ Again, for (92) to hold, we need to analyze the prepositions as a mere reflex of Case (*a* and *de* being the way T features are spelled-out when on D and C*) or else assume they do not to project a PP, being more like prefixes.³⁶ Given that both *a* and *de* yield interpretive effects (*a* is related to animacy and *de* to evidentiality; see Torrego 1998a and Demonte & Fernández-Soriano 2005), I will assume that they are prepositions, but I will only take *de* to project a *bona fide* PP (see section 3.3. above for arguments against *a* projecting a PP in direct objects).

Demonte & Fernández-Soriano (2005) argue that *de* in dequeista C*Ps is a prepositional complementizer, in the sense of Kayne (1994; 2000). However, it seems problematic for *de* to be analyzed as a T head moved to C*, for we already have an instance of T-to-C movement in this structure: *que*.

An analysis that fares better is suggested by Demonte & Fernández-Soriano (2002: 5) themselves: “we would like to propose instead that *de* in the cases under study is the head of a dyadic structure (in the sense of Hale and Keyser’s proposal) taking C*P headed by *que* as its complement and a (null) neuter pronoun (similar to *lo* or *eso*, “that”) as its Specifier.” Their analysis is shown in (107):

³⁵ Although the logic in (92) is clear about the adjunct status of “governed prepositional objects,” I cannot offer a detailed analysis of these dependents. For my purposes, I adopt Demonte’s (1991) idea that the preposition is the spell-out of an aspectual head, and not a true preposition: in the terms explored here, this means that those prepositions are the manifestation of Agr_O or T_O. For additional discussion, see Demonte (1991) and Simoni (2003).

³⁶ In fact, Pesetsky & Torrego (2004) argue that Spanish *a* in examples like (102) is not a preposition, but a mere Case marker (an instance of *uT*, not *iT*).

(107)

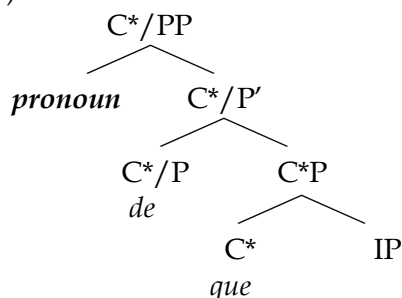

[from Demonte & Fernández-Soriano 2002: 5]

Data like those in (108) reinforce the paratactic analysis of (107):³⁷

(108)

- a. No repitas {**eso/lo**} de que no quieres venir. (D. Spanish)
 not repeat-SUBJ-2.SG that/it of that not want-SUBJ-2.SG come-INF
 ‘Don’t repeat that stuff about you not wanting to come’
- b. Cuando **eso** que me aconsejaron de que no me fuera... (D. Spanish)
 when that that CL-to-me advise-PAST-3.PL of that not CL-me go-SUBJ-PAST-1.SG
 ‘When that they told me about not leaving’

[from Demonte & Fernández-Soriano 2002: 7]

If the analysis in (107) is on track, then the C*P introduced by *de* is not a real dependent of the verb: the (null) pronoun is instead, with the C*P being a paratactic modifier. Refining (107) so that it fits with (92), I propose that dequeísta C*Ps are unlabeled syntactic objects too:

(109)

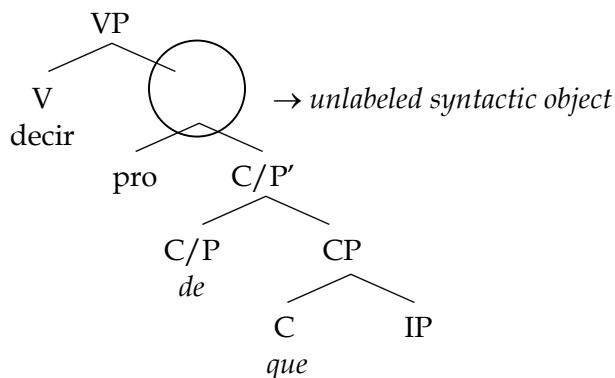

³⁷ Note that the analysis in (109) is virtually identical to that proposed by Torrego & Uriagereka (1992) in the case of indicative dependents.

With these ideas as background, let us go back to the C/ACoE: recall that the key intuition is that prepositions block agreement, ‘shielding’ the DP/C*P they undergo Merge with (prepositions qualify as *valued T* and render the relevant syntactic objects inactive, blocking ϕ -feature Match). The idea fits with Boeckx’s (2003a) observations on islandhood:

Agree cannot target adjuncts, as adjuncts have inert ϕ -features. Nor can it target anything inside adjuncts, as no material contained inside adjuncts ever triggers agreement outside them. It is an interesting issue to determine why the ϕ -features of adjuncts are inert, and why it renders everything the adjunct dominates opaque to ϕ -feature agreement. But the fact is that they are. Language after language, we see that adjuncts never participate in ϕ -feature sharing, unlike arguments. Also, the Case of adjuncts always appears to be inherent, either through the use of a preposition, or the default use of some Case form (accusative, e.g.), or of a peripheral Case (allative, e.g.). I will not speculate here about what that follows from, but I will make this as a fact: Agree is restricted to selected domains (arguments). [from Boeckx 2003a: 100]

Let us be a little bit more precise about this reasoning. What we need to understand is why a ϕ -Probe launched by, say, v^* or T_O , cannot bypass the preposition in order to Match the ϕ -features of P’s complement DP, as indicated in (110):³⁸

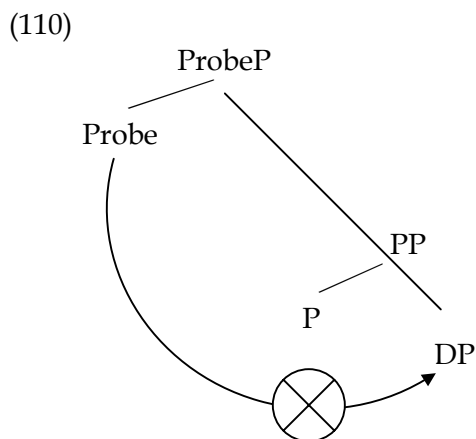

Given the availability of long-distance Agree, it is not clear what should go wrong in (110). According to the C/ACoE, the PP is an island because it bears valued T, this is

³⁸ It could be argued that adjuncts are opaque due to their being projected in a parallel plane (see Chomsky 2004). Although this idea can be maintained for some phenomena (Lebeaux’s effects), it is a robust observation that adjuncts show standard connectivity effects (see Hornstein et al. 2005, Pesetsky 1995, and Uriagereka 2003).

what causes the minimality effect. However, minimality effects are typically understood as there being a *defective intervener* (see chapter 3): that is, for P to be an intervener, it should be endowed with some feature both the would-be Probe and the would-be Goal have. I will assume so, taking it that the φ -Probe matches the preposition, because it bears φ -features.

Here technical details become important: what is the nature of the φ -bundle of prepositions? I will assume, following Abels (2003) that PPs are phase domains. Hence, in accord with what was discussed in chapter 2, I assume that prepositions bear all the relevant features their complements do, as indicated in (111):³⁹

(111)

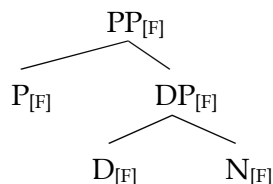

In (111), F stands for both T and φ -features, the latter being valued in the DP, the former in the preposition. Suppose that after the necessary valuation processes within the PP phase take place, we get (112):

(112)

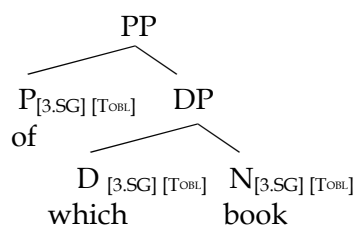

Once Transfer applies, only interpretable features should remain. Consequently, P has no φ -features left. How can there be an intervention effect, then? I claim that, by the fact of having had a φ -feature bundle, P (much like C* in embedded clauses) allows for default (just [person]) agreement, precluding the higher φ -Probe to go deeper: if P were to keep its φ -feature bundle undeleted, then verbs should be able to freely agree with DPs within all kinds of PPs, contrary to fact.

³⁹ See Kitahara (1997), Salles (2001), and Stepanov (2002) for alternatives implementations of the same basic idea, which goes back to Chomsky (1973).

If properly qualified, this analysis can provide us with an account of why sub-extraction from adjuncts is impossible: if these dependents are always headed by a preposition, then they will run the same fate than the *wh*-phrases in (113). The only way for the derivation not to crash would be to move the whole adjunct –that is, to extract the adjunct, not sub-extract from it. Both situations are pictured below:

(113)

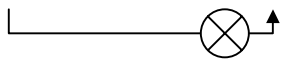
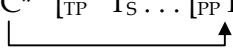
- a. $[_{C^*P} C^* [_{TP} T_S \dots [_{PP} P [_{DP} \dots]]]]$ *sub-extraction from PP*

- b. $[_{C^*P} C^* [_{TP} T_S \dots [_{PP} P [_{DP} \dots]]]]$ *extraction of PP*

Consider a particular case of the relevant asymmetry:

(114)

- a. $*[_{C^*P} \text{When}_i C^* \text{ do } [_{TP} \text{you talk to John } [_{PP} \text{since } t_i]]] ?$
 b. $[_{C^*P} \text{Since when}_i C^* \text{ do } [_{TP} \text{you talk to John } t_i]] ?$

The analysis carries over to clausal environments, as the Spanish data in (115) show: whenever a complement *C*P* is introduced by a preposition (*de*, in so-called *dequeísta* Spanish dialect), extraction is barred.

(115)

- a. $*[_{C^*P} \text{Qué cosa } C^* \text{ me dijiste } [_{PP} P \text{ de que habías comprado } t_i]] ?$ (D.Spanish)
 what thing CL-to-me tell-PAST-2.SG of that have-PAST-32.SG bought
 ‘What did you tell me of that you had bought?’
- b. $*[_{C^*P} \text{Dónde}_i C \text{ sabes } [_{PP} P \text{ de que vive } t_i]] ?$ (D.Spanish)
 where know-2.SG of that live-3.SG
 ‘Where do you know of that he lives?’
- c. $*[_{C^*P} \text{De qué modo}_i C^* \text{ dijiste } [_{PP} P \text{ de que resolvió el problema } t_i]] ?$ (D.Spanish)
 of what way say-PAST-2.SG of that solve-PAST-3.SG the problem
 ‘Which way did you say of that he solved the problem?’

[from Demonte & Fernández-Soriano 2005: 1070]

The just sketched analysis must also face non-trivial empirical problems. As is known, languages like English allow sub-extraction from adjuncts if the preposition they are introduced by is stranded:

(116)

- a. [_{C*P} Which city_i C* does Mary work [_{PP} P in t_i]]?
- b. [_{C*P} Who_i C* does your brother work [_{PP} P with t_i]]?
- c. [_{C*P} What topic_i C* you do not want to talk [_{PP} about t_i]]?

The literature has considered different ways to account for preposition stranding, normally assuming processes of “V-P reanalysis” or “D-to-P incorporation” (see Abels 2003: chapter 4 and Law 2006 for a recent review).

I would like to argue that facts like (116) pose no problem to the C/CoAE. In particular, I claim that for sub-extraction to be possible in these examples, the preposition must have undergone a reanalysis process with v^* -V, as originally proposed by Hornstein & Weinberg (1981) (recall also Boeckx’s 1991 account of the *Experiencer Paradox* as involving reanalysis).

Technically, for reanalysis to take place there must be an Agree dependency between v^* -V and the P that ‘removes’ the PP boundary out of the way, allowing v^* to probe the wh-phrase, and that should be possible if v^* -V and P share T and ϕ -features.

Notice that the logic is essentially that of *Phase Sliding* (see chapter 2): the moment we move a phase head (here, P), we slide the phase up to the projection where the phase head moves, and the PP becomes (at the relevant level of abstraction) a *bona fide* complement, being transparent.⁴⁰

⁴⁰ Putting differences aside, the same happens with those PPs that are analyzed as complements by Hale & Keyser (2002), in locatum and location verbs.

(117) Prepositional Phase Sliding

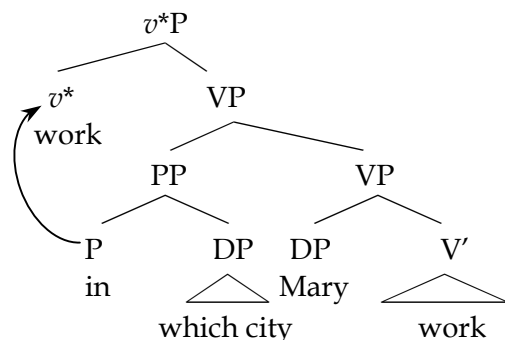

Interestingly, it seems that the process sketched in (117) requires prepositions to be light, for otherwise incorporation fails, and islandhood cannot be circumvented:

(118)

- a. *[_{C*P} Which film_i C* did John sleep [_{PP} during t_i]]?
- b. *[_{C*P} What day_i C* did you call Mary [_{PP} after t_i]]?

This idea is reinforced by data from Spanish. Consider the following contrast, taken from Gallego (2007a) (for similar observations, see Browning 1987): as (119) shows, only light *a* (as opposed to heavier *para*) allows sub-extraction of *a quién* (Eng. *to whom*):⁴¹

(119)

- a. [_{C*P} A quién_i C* vienes [a ver t_i]]? (Spanish)
to whom come-2.SG to see-INF
‘Who do you come to see?’
- b. *[_{C*P} A quién_i C* vienes [para ver t_i]]? (Spanish)
to whom come-2.SG for see-INF
‘Who do you come to see?’

⁴¹ The analysis predicts that sub-extracting out of *about* PPs should be ruled out, but it is not (see also 116c above):

(i) [_{C*P} What_i C* are you talking [_{PP} about t_i]]?

For reasons I fail to see, *about*, though heavy, allows reanalysis. Perhaps decomposition of *about* as *ab* + *out* would provide a way to account for (116c) and (i) –*about* would then qualify as a complex preposition, resulting from incorporation of *ab* into *out*. I leave this issue unsolved.

The fact that some languages (mostly, Germanic ones, but not all of them) can resort to this reanalysis strategy calls for an explanation in parametric terms. Syntactically, it is very intriguing to note, in addition, that precisely those languages displaying *P-Phase Sliding* appear to lack *v*-Phase Sliding*. The correlation, thus, appears to be as in (120):

(120) Languages with ‘rich’ C*-T-*v** system, have a weak P-D-N system, and vice-versa

(120) tries to encode the hypothesis that languages like English, which lack *v*-Phase Sliding*, display *P-Phase Sliding*. It is tempting to relate these facts to parametric variation within the PP (as pointed out by Boeckx 2006a: 143 and Sigusaki 2002; see Abels 2003: 242 and ff.). To be concrete, the mentioned authors argue that P-stranding languages allow for an additional layer above PP that grants movement without violating anti-locality. In non-P-stranding languages, P behaves like a syntactic affix, blocking extraction.

(121)

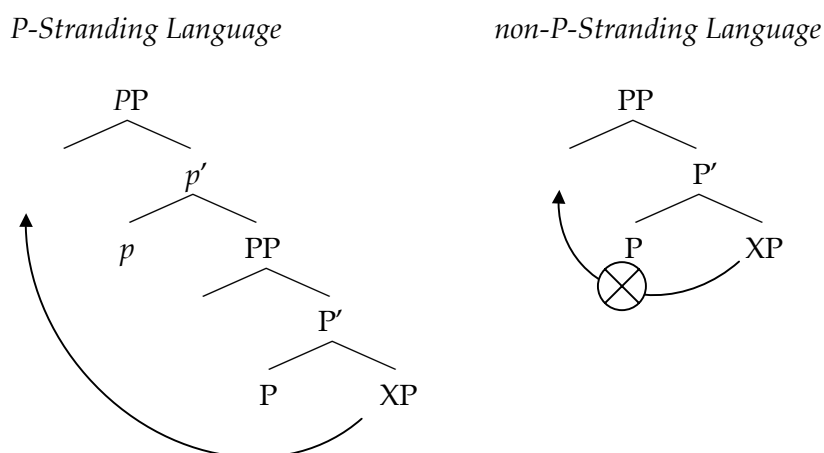

At first glance, (121)'s *pP* is identical to Torrego's (1998a) *pP*, an inflectional category introducing datives, suggesting (again) an asymmetry between having rich verbal inflection and rich prepositional inflection.

Most interestingly, Sugisagi (2002) argues that the structural difference in (121) has non-trivial consequences for interpretation. In particular, he relates the different syntax in (121) to the well-known contrast in (122): as noted by many scholars (see Mateu 2002

for updated discussion), the PP in English can have both a locative and a directional interpretation, while the PP in Spanish can only have a non-directional interpretation.⁴²

(122)

- a. The bottle floated under the bridge. *the bridge = location/goal*
 b. La botella flotó bajo el puente. *el puente = location/*goal* (Spanish)
 the bottle float-PAST-3.SG under the river
 ‘The bottle floated under the bridge’

Sugisaki (2002) suggests that the additional interpretation that the PP has in English is indicative of the presence of an additional layer of structure (the *pP*).

To deal with languages like German or Russian, where prepositions behave semantically like English prepositions, Sugisaki (2002) argues for a parameter regulating P-to-*p* movement: for Sugisaki (2002), P-to-*p* allows P-stranding. If correct, then languages of the Spanish type generally lack this possibility, because there is no *p*, or else because P has undergone m-merger with the lower D head (if prepositions generate below DP, as suggested by Pesetsky & Torrego 2004). I leave this matter for future investigation.

This section has explored the relevance of the C/ACoE in the case of adjuncts (and other elements introduced by a preposition, like complement clauses in dequeísta dialects of Spanish). As we have seen, sub-extraction in those instances is impossible: under the C/ACoE, Ps block agreement, which is a prerequisite for sub-extraction.

⁴² Mateu (2002) develops an analysis of this asymmetry, trying to recast Talmy’s (2000) typology in syntactic terms. In his analysis, Mateu (2002) argues that while English typically instantiates *satellite-framed languages* (i.e., languages which somehow incorporate “manner” adjuncts), Spanish instantiates *verb-framed languages* (i.e., languages that incorporate a “path” component).

However plausible, this analysis might be threatened by so-called “manner incorporation,” in the sense of Harley (2005). As (i) and (ii) show, it seems that both English and Spanish incorporate instrumental adjuncts of the *with a hammer* sort:

- (i) John hammered the metal (= John hit the metal with a hammer)
 (ii) Juan martilleó el metal. (Spanish)
 Juan hammer-PAST-3.SG the metal
 ‘Juan hammered the metal’

These topics need further investigation.

Notice that, if we extend the logic about PPs to TPs (assuming P and T belong to the same mega-category; see Pesetsky & Torrego 2004), both T_SP and T_OP should behave as islands. This entails that for any XP to escape out of these domains, they must have moved to their SPECs first –that is, to their *edge*:

(123)

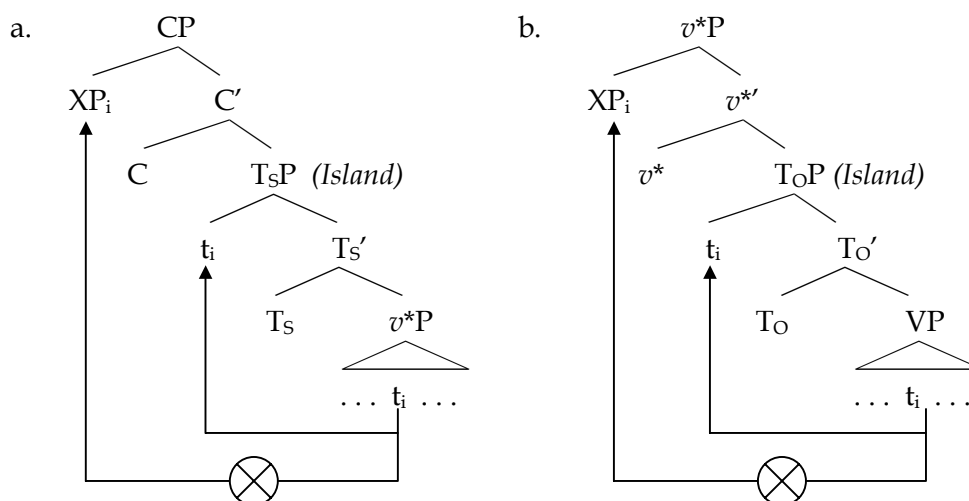

(123) tries to capture the idea that XP cannot reach SPEC-C* or SPEC-v* without having moved to SPEC-T_S and SPEC-T_O first. This scenario is consistent with Takahashi’s (1994) view of successive cyclic movement, adopted here (see chapter 2), and reinforces the gist of the C/ACoE: P and T are island inducer categories, so if any element within them wants to escape, additional steps must be taken (successive cyclic movement, reanalysis, etc.).

6. Sub-extraction from SPEC-C*: *Criterial Freezing and the Minimal Link Condition*

In section 2 it was noted that sub-extraction from phrases displaced to SPEC-C* is degraded, as predicted by Chomsky’s (to appear) analysis of CED effects:

(124)

- a. ??[_{C*P} Who_i C* do you wonder [_{C*P} [which picture of t_i]_j C* Mary bought t_j]]?
- b. ??[_{C*P} Who_i C* do you wonder [_{C*P} [which picture of t_i]_j C* t_j is on sale]]?

[from Lasnik & Saito 1992: 102]

Let us recall Gallego & Uriagereka's (2007) generalization to describe (124):

(125) **EDGE CONDITION**

Syntactic objects in phase edges are internally frozen

It was also noted that the *Edge Condition* is akin to Rizzi's (2006) *Criterial Freezing*: the difference being that Rizzi's (2006) cases of freezing arise when the configuration yields interpretive effects:

(126) **CRITERIAL FREEZING (non-final version)**

A phrase meeting a criterion is frozen in place

[from Rizzi 2006: 112]

As Rizzi (2006) points out, *Criterial Freezing*, as formulated above, can deal with (127):

(127)

- a. Bill wonders [_{C*P} which book_i C* she read t_i]
- b. *[_{C*P} Which book_i C* does Bill wonder [_{C*P} t_i C* she read t_i]]

[from Rizzi 2006: 112]

Rizzi (2006: 112) suggests that (127b) is ruled out because the wh-phrase *which book* is used to satisfy the *Question Criterion* twice –in embedded and matrix clauses. Differently put, what goes wrong with (127b) is that *which book* undergoes 'too much checking.'

The same holds for examples like (128), where trying to topicalize a wh-phrase results in an illicit output (see Lasnik & Saito 1992 for discussion):

(128) *[_{C*P} Who_i thinks [_{C*P} that, which problem_i, Mary hates t_i]]?

[from Bošković 2005: 5]

Bošković (2005) pursues a version of Chomsky's (2000; 2001) *Activity Condition* in order to account for (128). Broadly, he contends that A-bar XPs are endowed with an uninterpretable [Op(erator)] feature that, when in the appropriate checking configuration, is deactivated. Bošković's (2005) *Operator Freezing Effect* was formulated in section 2, but I repeat it here for convenience:

(129) OPERATOR FREEZING EFFECT

Operator in operator-variable chains cannot undergo further operator-movement
[from Bošković 2005: 1]

Under (129), the [Op] feature of *which problem* in (128) renders the wh-phrase active until it hits a position where the wh-phrase gets its scope (in Rizzi's 1997 terminology, SPEC-Focus). Once in that position, the [Op] feature is frozen, which disallows *which problem* to engage a criterial checking in SPEC-Top.

Even though the facts raised by Lasnik & Saito (1992) open a promising door, empirical evidence suggests that no version of Wexler & Culicover's (1981) *Freezing Principle* described so far is able to accommodate all the data. The first problematic case concerns sub-extraction from post-verbal subjects in Spanish (see section 3.1.).

A second problem has to do with Esther Torrego's data in the mid 80s. Those facts demonstrate that complex wh-phrases in SPEC-C* can obviate freezing effects, somehow allowing sub-extraction. Consider the relevant example, one more time:

(130) [_{C*P} De qué autora_i C* no sabes [_{C*P} [qué traducciones t_i]_z C* [t_z han . . .
of what author not know-2.SG what translations have-3.PL
. . . ganado premios internacionales]]]? (Spanish)
won awards international

'Which author don't you know which translations by have won
international awards?'

[from Torrego 1985: 31]

Sentences of this kind are hard to process (a wh-phrase within another wh-phrase), but the judgment is rather clear: the output is fine, just like in Italian:⁴³

- (131) ?_[C*P] Di quale autore_i C* ti domandi _[C*P] [quanti libri t_i]_z C* . . .
of which author CL-to-you wonder-2.SG how-many books
. . . siano stati censurati t_z]]? (Italian)
have-3.PL been censured
‘Which author do you wonder how many books by have been censured?’
[from Rizzi 2006: 114]

Notice that (130) and (131) are at odds with the logic of Rizzi’s (2006) *Criterial Freezing*. In order to get around this drawback, Rizzi (2006; to appear) weakens its definition, pointing out that:

[W]e have seen that part of the phrase involved in the satisfaction of a criterion remains available for further movement, as in the splitting illustrated by [131]. So the freezing effect is limited to the element actually carrying the feature involved in the satisfaction of the criterion (a more accurate wording of Criterial Freezing would then be something like “In a specifier-head criterial configuration, the element bearing the criterial feature in the specifier position is frozen in place”).
[from Rizzi 2006: 127 –emphasis added, AJG]

Rizzi (to appear) refines *Criterial Freezing* as follows:

⁴³ In Chomsky (1986a: 25-26), Torrego’s (1985) paradigm was accounted for by arguing that matrix verbs are able to properly govern embedded fronted wh-phrases. What Chomsky (1986a) wanted to prove is that, whereas the SPEC of C*P can be governed by a higher verb, the SPEC of IP cannot –that is what the contrast in (i) and (ii) was taken to follow from:

- (i) *Esta es la autora _[C*P] [de la que]_i C* _[TP] [varias traducciones t_i] T_S han . . .
this be-3.SG the author of the which several translations have-3.PL
. . . ganado premios internacionales]] (Spanish)
won awards international
‘This is the author of which several translations have won international awards’
(ii) _[C*P] De qué autora_i C* no sabes _[C*P] [qué traducciones t_i] C* han . . .
of what author not know-2.SG what translations have-3.PL
. . . ganado premios internacionales]]? (Spanish)
won awards international
‘Of which author don’t you know which translations by have won international awards?’

[from Chomsky 1986: 26]

(132) **CRITERIAL FREEZING (final version)**

[Only t]he Criterial Goal is frozen in place

[from Rizzi to appear: 2]

This weaker version of the *Criterial Freezing* can now deal with (130) and (131), as it defines a more sophisticated satisfaction procedure. Consider, step-by-step, the derivation of (131): (133) is intended to capture the moment when the embedding wh-phrase, *quanti libri* (Eng. *how many books*) is frozen due to satisfaction of the *Question Criterion* of the embedded C*:

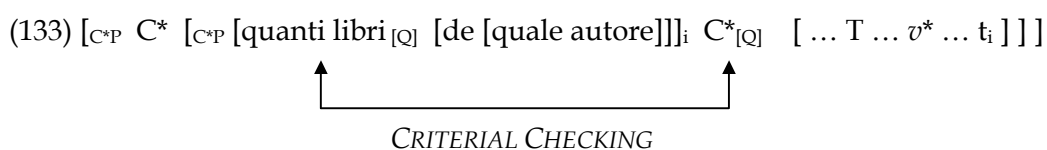

In the next step, the buried wh-phrase, *de quale autore* (Eng. *of which author*), leaves the higher one stranded, and is raised to matrix SPEC-C*, where the second *Question Criterion* is checked off.

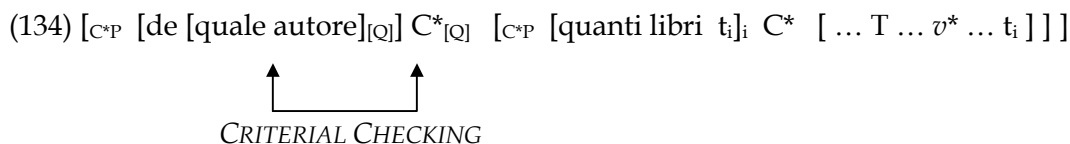

Though at first glance consistent with the facts noted by Torrego (1985) and Rizzi (2006), the process in (133)-(134) raises the question of how come the (internal) part of an XP does not freeze if the latter does –note that the frozen material in the first step does not even form a constituent. This is highlighted in (135):

(135) *Freezing of Criterial Goal*

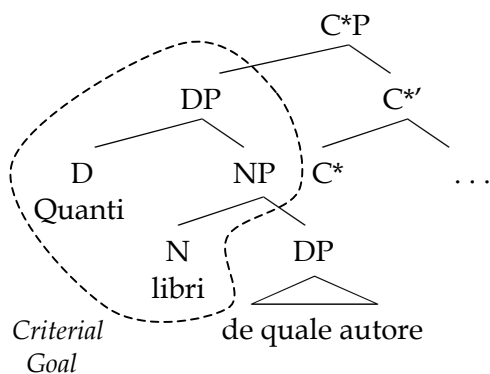

Setting that aside, and even if the *Edge Condition* is shown to be irrelevant, it should be noted that the Torrego (1985)/Rizzi (2006) data also violate a well-known locality constraint, Chomsky's (1973) *A-over-A Condition*:

(136) **A-OVER-A CONDITION**

If a transformation applies to a structure of the form . . .

[α . . . [A . . .] . . .]

. . . where α is a cyclic node then it must be so interpreted as to apply to the maximal phrase of the type A

[from Chomsky 1977: 85]

In other words, (130) and (131) challenge not only Chomsky's (to appear) phase-based analysis of CED, but also the *A-over-A Condition*.

In the next sections I claim that the particular data in (130) and (131) have been misanalyzed. I run some tests that point to the conclusion that the alleged sub-extracted PP is actually base generated outside the embedded wh-phrase, as a PP dependent of the matrix verb: an aboutness phrase. I also consider some evidence studied by Gallego (2005) and Uriagereka (2004) showing that negation somehow ameliorates sub-extraction in the cases Esther Torrego originally provided. If these ideas are on track, then it remains to be explained why real sub-extraction out of complex wh-phrases (like the ones noted by Lasnik & Saito 1992) is so degraded. Building on Gallego & Uriagereka (to appear), I argue that the first formulation of

Rizzi's (2006) *Criterion Freezing* (the most restrictive one) is the one making the right predictions.

6.1. Uriagereka's (2004) Analysis

This section considers a first factor that Uriagereka (2004) (and, following him, Gallego 2005) takes to have an ameliorating effect on sub-extraction from displaced constituents: the *de re* vs. *de dicto* distinction.

Uriagereka (2004) addresses the data in Torrego (1985), arguing that structures like (137b) are structurally ambiguous, since the *wh*-phrase *qué traducciones* (Eng. *which translations*) can be analyzed as a sort of adjunct (not a true SPEC), a technical solution that, given the assumptions made by this author, avoids the spell-out of the *wh*-phrase so that sub-extraction is still possible. In order to see the logic of Uriagereka's (2004) proposal, consider the structures in (137):

(137)

- a. Ya sé qué novelas de Javier Marías están a la venta. (Spanish)
 already know-1.SG what novels of Javier Marías be-3.PL to the sale
 'I already know what novels by JM are on sale'
- b. Ya sé las novelas de Javier Marías que están a la venta. (Spanish)
 already know-1.SG the novels of Javier Marías that be-3.PL to the sale
 'I already know the novels by JM that are on sale'

According to Uriagereka (2004), (137a) can yield both *de re* and *de dicto* readings, being hence structurally ambiguous between a true selected embedded *wh*-question and a species of embedded clause with a topicalized *wh*-phrase.

Such difference perhaps becomes more conspicuous in (138): under the *de re* reading, the speaker can go on and point out which novels are on sale (since he has the specific novels in mind).

(138)

- a. Ana dijo qué novelas de Javier Marías habían ganado . . .
 Ana say-PAST-3.SG what novels of Javier Marías had-3.SG won
 . . . un premio: *Corazón tan blanco, Cuando fui mortal, etc.* (Spanish)
 an award Heart so white, When be-PAST-1.SG mortal, etc.
 ‘Ana said which novels by JM had won a prize: *Heart so white, When I was mortal, etc.*’
- b. Ana dijo qué novelas de Javier Marías habían ganado . . .
 Ana say-3.SG what novels of Javier Marías had-3.SG won
 . . . un premio. Pero eso no es lo que yo quería saber. (Spanish)
 an award but that not be-3.SG the that I want-PAST-1.SG know-INF
 ‘Ana said which novels by JM had won a prize. But that is not what I wanted to know’

Only in (138a) the expression is “object-centered” (to use Uriagereka’s 2004 terms), and the *wh*-phrase *qué novelas de Javier Marías* (Eng. *which novels by Javier Marías*) can receive a *de re* reading. In (138b), on the other hand, the expression is “thought-centered,” as the pronoun *eso* (Eng. *that*), which refers to the whole clause, indicates – consequently, only a *de dicto* reading is available.

Importantly, adding the complementizer *que* (Eng. *that*) before the *wh*-phrase forces the *de dicto* interpretation of the embedded C*P, as Raquel González observes. In fact, when we use *que, decir* (Eng. *say*) has the interpretation of *preguntar* (Eng. *ask*):

(139)

- a. Ana dijo qué novelas de Javier Marías habían . . .
 Ana say-PAST-3.SG what novels of Javier Marías had-3.SG
 . . . ganado un premio. {*de dicto/de re*} (Spanish)
 won an award
 ‘Ana said which novels by Javier Marías had won a prize’
- b. Ana dijo que qué novelas de Javier Marías habían . . .
 Ana say-PAST-3.SG that what novels of Javier Marías had-3.SG
 . . . ganado un premio. {*de dicto/*de re*} (Spanish)
 won an award
 ‘Ana asked which novels by JM had won a prize’

Interestingly for my purposes, trying to sub-extract from (139b) yields severe deviance:

- (140) *_{[C*P} De qué escritor_i C* dijo Ana _{[C*P} C* que [qué novelas t_i] . . .
of what writer say-PAST-3.SG Ana that what novels
. . . habían ganado un premio] (Spanish)
Had-3.SG won a prize.
‘Which writer did Ana ask which novels by had won a prize?’

But let us go back to (137), and, in particular, to the (137b) case, which Uriagereka (2004) attributes to Héctor Campos and treats as a sort of C*P with a topicalized DP.⁴⁴ According to Uriagereka (2004), (137b) can only have the *de re* reading, so, capitalizing on this contrast, he argues that (137a) can receive a double analysis, depending on whether the wh-phrase is a true interrogative wh-phrase (forcing a *de dicto* reading) or a topicalized wh-phrase (forcing the *de re* one).

What we must find out is what the difference between being a “true SPEC” and an “adjunct SPEC” is. In Uriagereka’s (2004) system, only true SPECS flatten and become frozen units, which predicts that adjoined ones may still allow sub-extraction. As (148) shows, the prediction is correct under the assumption that the topicalized DP *las traducciones* (Eng. *the translations*) is adjoined somewhere in the C*P, crucially without qualifying as a SPEC:

⁴⁴ See Brucart (1993; 1994b) for a similar analysis, and more related intriguing issues.

Uriagereka (2004) dismisses the possibility of analyzing (137b) as a relative clause because a true relative pronoun like *el cual* (Eng. *the which*) cannot replace *que*. I agree, but that is not a good test, since it follows from a more general restriction about overt relative pronouns in Romance languages: they are possible only if introduced by a preposition (see Brucart 1992):

- (i) La chica {que/*la cual} te gusta. (Spanish)
the girl that/ the which CL-you likes-3.SG
‘The girl {that/who} you like’
(ii) La chica con la {que/cual} sales. (Spanish)
the girl with the that/which go-out-2.SG
‘The girl you go out with’

Another problem for a relative analysis of (137b) comes, I guess, from the fact that the C*P-chunk cannot be eliminated:

- (iii) Ya sé las novelas de Javier Marías *(que están a la venta). (Spanish)
already know-1.SG the novels of Javier Marías that be-3.PL to the sale
‘I already know the novels by JM that are on sale’

(iii) is misleading, though. In (iv) it can be seen that there are some relative clauses that cannot be eliminated either:

- (iv) I miss the Barcelona *(that I knew when I was a child).

- (141) [_{C*P} De qué autora_i C* no sabes [_{C*P} [las traducciones t_i]_j C* que t_j están . . .
of what author not know-2.SG the translations that be-3.PL
. . . a la venta]]? (Spanish)
at the sale
‘Which author don’t you know the translations by that are on sale’
[from Uriagereka 2004: 38]

Uriagereka (2004) eventually concludes that Torrego’s (1985) examples in which sub-extraction is possible are to be analyzed with the *wh*-element as a topicalized phrase that has a *de re* interpretation, as (142) indicates (notice that, for Uriagereka 2004, it is the stranded/intermediate *wh*-phrase *qué traducciones* that receives the *de re* reading):

- (142) [_{C*P} De qué autora_i no sabes [_{C*P} [qué traducciones t_i]_j t_j están a la venta . . .
of what author not know-2.SG what translations be-3.PL at the sale
‘Of which author don’t you know what translations are on sale
. . . # y de hecho dudas que haya ninguna? (Spanish)
and of fact doubt-2.SG that there-be-SUBJ-3.SG anyone
... and actually you doubt that there is any?’
[from Uriagereka 2004: 39]

In (142), the *de dicto* reading (the one in which the speaker does not have in mind some specific novels whose existence is presupposed) is forced by the added comment, and sub-extraction is worse. Uriagereka (2004) takes this fact to suggest that *in the cases in which sub-extraction is possible, the wh-phrase is not a specifier*.

I agree with Uriagereka’s (2004) intuition about the *de re* / *de dicto* contrast, but I do not think we need to analyze those *de re* *wh*-phrase as topics (that would be problematic, assuming they also have to satisfy their interrogative role, according to Bošković 2005 and Rizzi 2006). The key factor for me in forcing the *de re* reading is the negative part of the expression *no saber* (Eng. *not to know*) the one used by Esther Torrego. As far as I know, this has gone unnoticed in all analysis of Torrego’s (1985) original data I am familiar with.

Therefore, to my ear, examples without negation seem to me to be more degraded than those with it. To test this, consider the data in (143) and (144), where, following Uriagereka's (2004) strategy, I use afterthoughts to induce a *de re* or *de dicto* readings for the embedded C*P:

(143)

- a. ??/*_[C*P] De qué autora_i C* sabes _[C*P] [qué traducciones t_i] C* t_j están . . .
of what author know-2.SG what translations be-3.PL
. . . a la venta]]? (...y no se lo dijiste a Ana) (Spanish)
at the sale (...and not CL CL-it say-PAST-2.SG to Ana)
'Which author do you know which translations by are on sale?
(...and you did not say that to Ana)'
- b. _[C*P] De qué autora_i C* no sabes _[C*P] [qué traducciones t_i] C* t_j están . . .
of what author not know-2.SG what translations be-3.PL
. . . a la venta]]? (...y no se lo dijiste a Ana) (Spanish)
at the sale (...and not CL CL-it say-PAST-2.SG to Ana)
'Which author don't you know which translations by are on sale?
(...and you did not say that to Ana)'

(144)

- a. ?_[C*P] De qué autora_i C* sabes _[C*P] [qué traducciones t_i] C* t_j están . . .
of what author know-2.SG what translations be-3.PL
. . . a la venta]]? (...pero no querrías leerlas) (Spanish)
at the sale (...but not like-COND-2.SG read-INF-CL-them)
'Which author do you know which translations by are on sale?
(...but you would not like to read them)'
- b. ?_[C*P] De qué autora_i C* no sabes _[C*P] [qué traducciones t_i] C* t_j están . . .
of what author not know-2.SG what translations be-3.PL
. . . a la venta]]? (...pero no querrías leerlas) (Spanish)
at the sale (...but not like-COND-2.SG read-INF-CL-them)
'Which author don't you know which translations by are on sale?
(...but you would not like to read them)'

In this context, it is relevant to point out that negation is also a strategy to save a long-distance extraction of adjuncts (see Rizzi 1991):

(145)

- a. *[_{C*P} Cómo_i; C* no dijo Luis [_{C*P} qué libros_i; C* leyó Ana t_i t_j]]? (Spanish)
 how not say-PAST-3.SG Luis what books read-PAST-3.SG Ana
 ‘How didn’t Luis say what books Ana read?’
- b. [_{C*P} Qué libros_i; C* no dijo Luis cómo_i; leyó Ana t_i t_j]? (Spanish)
 what books not say-PAST-3.SG Luis how read-PAST-3.SG Ana
 ‘What books didn’t Luis say how Ana read?’

As Rizzi (1991) noted, (145b) is good, with long-distance extraction of an argument, which –in his analysis– bears a referential index that allows a binding strategy to properly govern its trace. (145a) is –I agree with Rizzi (1991)– out. But note that there is still a way of saving (145a): if there is a previous context in which Luis said that Ana read some books in many different ways (e.g., *slowly*, *gracefully*, *standing*, etc.), then one can come up and ask (145a) if he wants to find out what the specific way(s) in which Luis did not say Ana read some books is.

Now, one important issue remains to be addressed: which one of the two wh-phrases is the one that receives the *de re* reading? According to my own judgments, there is a strong preference for the first one (that is, the one that ends up in the matrix SPEC-C*) to be interpreted presuppositionally. So, the rough interpretation of Torrego’s (1985) original example, repeated in (146a), would be as in (146b):

(146)

- a. [_{C*P} De qué autora_i; C* no sabes [_{C*P} [qué traducciones t_i]; t_j están . . .
 of what author not know-2.SG what translations be-3.PL
 . . . a la venta]]? (Spanish)
 to the sale
 ‘Of what author don’t you know what translated books are on sale?’
- b. $\exists x, x = \text{author}$, for what x you do not know that $y, y = \text{translations of } x$, are on sale.

The intuition I am trying to capture in (146b) is that the *wh*-phrase *qué autora* (Eng. *which author*) has wide scope over the main clause, being presupposed, with the restriction *autora* not undergoing downstairs reconstruction (see Fox 2000 and Heycock 1995). So, for me, it is this *wh*-phrase, and not the embedded one (i.e., *qué traducciones*) that is preferably presupposed. If this is so, we expect that (146a), repeated below as (147a), is interpreted as a *simple matrix question*, and not as a *multiple matrix question*,⁴⁵ with (147b) as its answer. Were it multiple, then the speaker could answer as in (147c) (actually, I think Uriagereka 2004 is right, and 147c is a possible answer; all we have to do is force a *de re* reading of the stranded *wh*-phrase *qué traducciones* too, but, as just said, in that case we would have a sort of disguised matrix multiple question):

(147)

- a. [C*_P De qué autora_i C* no sabes [C*_P [qué traducciones t_j]; C* t_j están . . .
of what author not know-2.SG what translations be-3.PL
. . . a la venta]]?
to the sale
‘Of which author don’t you know what translated books are on sale?’
- b. No sé qué traducciones de Ana María Matute están a la venta. (Spanish)
not know-1.SG what translations of Ana María Matute be-3.PL to the sale
‘I do not know what translations of AMM are on sale’
- c. No sé si, de Ana María Matute, están a la venta. . .
not know-1.SG whether of Ana María Matute be-3.PL to the sale
. . . *Celebration in the Northwest y The Lost Children.* (Spanish)
Celebration in the Northwest and The Lost Children
‘I do not know whether, of AMM, the translations CitN and TLC are on sale’

In a nutshell: the easier the presuppositional reading of the *wh*-phrases, the better the sub-extraction. Note that both Uriagereka’s (2004) and Gallego’s (2005) analyses are tacitly reinforced by Lasnik & Saito’s (1992) data, since, as they already noted, if the *wh*-phrase undergoing sub-extraction is D-linked (involving *which*), sub-extraction improves:

⁴⁵ The LF representation of the matrix multiple question-version would be as in (i), putting aside whether one of the *wh*-phrases (or both) gets a presuppositional reading:

(i) for what *x*, *x* = author, for what *y*, *y* = translations, you do not know that *y* of *x* are on sale

(148)

- a. ?_{[C*P} Which athlete_i C* do you wonder _{[C*P}[which pictures of t_i]_j C* [Mary bought t_j]]]?
 b. ?_{[C*P} Which athlete_i C* do you wonder _{[C*P} [which pictures of t_i]_j C* [t_j are on sale]]]?

[from Lasnik & Saito 1992: 111]

In the next section I concentrate on a factor that, in Gallego & Uriagereka (to appear), we take to be the key for making sub-extraction from displaced constituents possible: a reanalysis of the sub-extracted PP as a matrix aboutness dependent.

6.2. PP Sub-extraction or “Aboutness” Dependents?

Let us start this section by considering the relevant abstract pattern of Torrego’s (1985) and Rizzi’s (2006) examples:

(149)

$$a. [{}_{C^*P} C^* [{}_{TP} T_S [{}_{v^*P} v^* \left[\begin{array}{c} [{}_{C^*P} [wh- [of [wh-]]]_j C^* [T [v^* \dots t_j]]]]] \\ \text{----- EDGE -----} \end{array} \right]]]]]$$

$$b. [{}_{C^*P} [PP of [wh-]]_i C^* [{}_{TP} T_S [{}_{v^*P} v^* \left[\begin{array}{c} [{}_{C^*P} [wh t_i]_j C^* [T [v^* \dots t_j]]]]] \\ \text{---- EDGE ----} \end{array} \right]]]]]$$

Gallego & Uriagereka (2007) provide examples analogous to the ones due to Torrego (1985) that seem to suggest that sub-extraction is really possible in these contexts.

(150)

- a. _{[C*P} De qué escritor_i C* no ha preguntado María ...
 of what writer not have-3.SG asked María
 ... _{[C*P} [cuántas novelas t_i] C* [t_j han tenido éxito]]? (Spanish)
 how-many novels have-3.PL had success
 ‘Of what writer hasn’t María asked how many novels have succeeded?’

- b. [_{C*P} De qué director_i C* no ha dicho María . . .
of what director not have-3.SG said María
. . . [_{C*P} [cuántas películas t_i]_j C* [t_j han ganado un Óscar]]? (Spanish)
how-many films have-3.PL won an Oscar
‘Of what director hasn’t María said how many films have won an Oscar?’
[from Gallego & Uriagereka to appear: 18]

This said, we noted that there is reason to be skeptical about sub-extraction to actually take place in cases like (130), (131), and (150): instead, as we suggest, the alleged sub-extracted PPs can be said to be generated as aboutness dependents of the matrix verb.⁴⁶ In fact, all the verbs that have been used to illustrate the relevant paradigms can easily adopt the aboutness structure “X verb Z de Y,” as in *Juan sabe eso de María* (Eng. *Juan knows that about María*), where “Z” and “de Y” do not form a constituent. If the wh-phrase is thus analyzed, there is no sub-extraction involved.

To be more precise about this, take the verb *saber* (Eng. *know*), the one used by Torrego (1985).⁴⁷ As indicated below, this verb exhibits two different selectional frames:

⁴⁶ The literature shows some growing eskepticism with respect to whether *of*-phrases are sub-extracted or base-generated as independent adverbial phrases (see Broekhuis 2005: 62-63). In this paper we assume the first possibility, following Chomsky (1977). Thus, *of*-phrases do form a constituent with DPs targeted for sub-extraction operations –and no ‘readjustment’ rule is needed.

A different approach is that of Kayne (2002), where examples like (i) are analyzed by taking the preposition *of* to be merged outside the VP. According to Kayne (2002), the derivation of (i) would be as indicated in (ii):

- (i) [_{C*P} Who C* was John admiring [a picture of]]?
(ii) a. . . . admiring [John a picture] → merger of *of*
b. . . . of admiring [John a picture] → movement of *John* to Spec-*of*
c. . . . John_i of admiring [t_i a picture] → merger of *W* and raising of *of*
d. . . . of_j + W John_i t_j admiring [t_i a picture] → movement of VP to Spec-*W*
e. . . . [admiring [t_i a picture]]_k of_j +W John_i t_j t_k

[from Kayne 2002: 72]

See section 7 for more discussion and qualifications.

⁴⁷ Esther Torrego points out to me through personal communication that I should run these tests with verbs that *only* select embedded interrogatives, like *preguntarse* (Eng. *wonder*) or *no saber* (Eng. *not to know/ignore*) –what Suñer (1999: 2153-2179) dubs *true indirect questions*.

Nevertheless, in order to test Chomsky’s (to appear) claim about edges, I think this is not necessary –actually, if anything, these verbs would introduce an extraneous factor: their wh-island inducer nature. What Chomsky (to appear) points out is nothing but a locality problem that is independent of semantic factors, like those posed by verbs that select interrogative dependents.

Recall, in addition, that Lasnik & Saito (1992) noted that this issue is not obviously relevant: the output is as degraded with *wonder* as it is with *think*:

- (i) ??[_{C*P} Who_i C* do you wonder [_{C*P} [which picture of t_i]_j t_j is on sale]]?

(151a), where it selects for a C*P, and (151b), where it selects for a C*P and an aboutness dependent –the PP *de María* (Eng. *of María*):

(151)

a. Juan sabía [C*P C* que María estaba cansada] (Spanish)

Juan know-PAST-3.SG that María be-PAST-3.SG tired

‘Juan knew that María was tired’

b. Juan sabía [PP de María] [C*P C* que estaba cansada] (Spanish)

Juan knowPAST-3.SG of María that be-PAST-3.SG tired

‘Juan knew about María that she was tired’

[from Gallego & Uriagereka to appear: 19]

Consider now versions of the relevant structures according to the duality in (151):

(152)

a. No sabes [C*P [qué traducciones [PP de qué autora]]_i C* ... t_i] (Spanish)

not know-2.SG what translations of what author

‘You do not know which translations by which author...’

b. No sabes [PP de qué autora] ... [C*P [qué traducciones]]_i C* ... t_i] (Spanish)

not know-2.SG of what author what translations

‘You do not know about which author which translations...’

[from Gallego & Uriagereka to appear: 19]

Crucially, in Gallego & Uriagereka (to appear) we follow Gallego (2005) in arguing that the examples in (152) hold the key to Torrego’s (1985) data. Only in (152a) does the would-be sub-extracted wh-phrase (the PP *de qué autora*) form a constituent with the stranded wh-phrase (the DP *qué traducciones*): that is the base configuration we must have in order to test whether sub-extraction really takes place.

(ii) ??[C*P Who_i C* do you think [C*P that [pictures of t_i]_j Mary believes t_j are on sale]]?
[from Lasnik & Saito 1992: 102]

Put differently, we must ascertain that *decir* (Eng. *say*) is analyzed as in (153a) below, where the PP *de Y* is buried within the projection of *Z*, and not as in (153b), where it is a direct dependent of *V*.

(153)

- a. [_{v*P} v* [_{VP} V [_{ZP} Z *de* Y]]] *non-aboutness structure*
 b. [_{v*P} v* [_{VP} [_{VP} V [*de* Y]] Z]] *aboutness structure*

Gallego (2005) and Gallego & Uriagereka (to appear) come up with tests that eliminate the possibility for the aboutness configuration to emerge, thus guaranteeing the correct structure to control for sub-extraction. Consider them.

The first test invokes binding: in particular, the examples in (154) contain elements that force reconstruction into the embedded clause:

(154)

- a. *[_{C*P} [De qué hijo suyo]_i C* sabes [_{C*P} [qué novelas t_i] C* ha leído todo padre]]?
 of what son his know-2.SG what novels have-3.SG read every father
 ‘Which son of his do you know which novels by has every father read?’
 b. *[_{C*P} [De qué fotos de sí misma]_i C* sabes [_{C*P} [qué cotilleos t_i] C* ha oído María]]?
 of what pictures of herself know-2.SG what gossip have-3.SG heard María
 ‘Which pictures of herself do you know which nasty comments of
 has María heard?’

[from Gallego & Uriagereka to appear: 19]

These sentences are out, as expected if the NP in the initial wh-phrase must be bound by the subject in the embedded clause: then the wh-phrase in point cannot have been base generated as a matrix aboutness dependent (the structure must be precisely of the sort Torrego had in mind). Notice that it is not obvious why the examples are bad, since, according to Torrego’s (1985) analysis, reconstruction should be possible, just like it is in both (155) and (156):⁴⁸

⁴⁸ Declarative versions of these examples are much better, as noted in Gallego & Uriagereka (to appear):

(i) Todo padre ha leído novelas de su hijo. (Spanish)
 every father have-3.SG read novels of her son

(155)

- a. [_{C*P} De qué hijo suyo_i C* ha leído todo padre v* [novelas t_i]]? (Spanish)
of what son his have-3.SG read every father novels
‘Which son of his has every father read novels by?’
- b. [_{C*P} De qué fotografías de sí misma_i C* ha oído María v* [cotilleos t_i]]? (Spanish)
of what pictures of herself have-3.SG heard María gossip
‘Which pictures of herself has María heard nasty comments of?’

[from Gallego & Uriagereka to appear: 20]

(156)

- a. ?[Sabes [_{C*P} [qué novelas [de qué hijo suyo]]_i C* ha leído todo padre t_i]]? (Spanish)
know-2.SG what novels of what son his have-3.SG read every father
‘Do you know which novels of which son of his has every father read?’
- b. ?[Sabes [_{C*P} [qué cotilleos [de qué fotos de sí misma]]_i C* ha oído María t_i]]? (Spanish)
know-2.SG what gossip of what pictures of herself have-3.SG heard María
‘Do you know which nasty comments about which pictures of herself has María heard?’

[from Gallego & Uriagereka to appear: 20]

In conclusion: the ungrammaticality in (154) must be a result of *bona fide* sub-extraction, this time forced by reconstruction configurations.

A second test to block an aboutness configuration consists in already having an aboutness phrase filling the gap in the main sentence, as Gallego (2005) first pointed out, following a suggestion by Leticia Pablos. This is done in (157a) below, where the PP *de Luis* (Eng. *about Luis*) plays the aboutness role. Now compare that example with (157b), where sub-extraction of the PP *de qué escritor* (Eng. *of which writer*) out of the embedded SPEC-C* takes place:

-
- (ii) ‘Every father has read novels by her son’
María ha oído muchas habladurías de fotografías de sí misma. (Spanish)
María have-3.SG heard much gossip of pictures of herself
‘María has heard many nasty comments about photographs of herself’

(157)

- a. Ana sabe *de Luis* [_{C*P} [qué novelas de Javier Marías]_i; C* ha leído t_i] (Spanish)
 Ana know-3.SG of Luis what novels of Javier Marías have-3.SG read
 ‘About Luis, Ana knows which novels by Javier Marías he has read’
- b. * [_{C*P} De qué escritor_i; C* sabe Ana *de Luis* [_{C*P} [qué novelas t_i]; C* ha leído t_j]] (Spanish)
 of what writer know-3.SG Ana of Luis what novels have-3.SG read
 ‘Which writer does Ana know about Luis which novels by he has read?’

[from Gallego & Uriagereka to appear: 20]

This time there is no way to relate the sub-extracted wh-phrase to the matrix verb, for that slot is already occupied by the PP *de Luis*. This may be the explanation for the ungrammaticality in this instance, as the example constitutes another case of *bona-fide* sub-extraction from the relevant site.⁴⁹

On the bases of these empirical tests, I therefore conclude that, if the possibility for the wh-phrase to be an aboutness phrase of the matrix predicate is controlled, as in (154) and (157), sub-extraction is indeed impossible, as Lasnik & Saito (1992) showed.

Luigi Rizzi (p.c.) finds these observations plausible, but he points out the asymmetry between (158a) and (158b). As Rizzi informs me, ungrammaticality of (158b) might indicate that there has been no reanalysis of the PP *del quale* (Eng. *of whom*) as an aboutness phrase:

⁴⁹ For reasons that suggest the relevant structures are quite complex (see Torrego & Uriagereka 2002), aboutness phrases create mild intervention effects, even in simple instances of wh-movement. Thus:

- (i) ?? [_{C*P} Qué fotografías_i; C* dijo Juan de María [_{C*P} que quería vender t_i]] (Spanish)
 what pictures say-PAST-3.SG Juan of María that want-PAST-3.SG sell-INF
 ‘As for María, which pictures did Juan say that she wanted to sell?’
- (ii) ?? [_{C*P} A quién_i; C* dijo Juan de María [_{C*P} que le había dado libros t_i]] (Spanish)
 to who say-PAST-3.SG Juan of María that CL-to-him had-3.SG given books
 ‘As for María, who did Juan say that she had given books to?’

To my ear, though, these examples sound better than (157b) –but the issue has to be investigated further.

(158)

- a. L'autore [_{C*P} del quale_i C* non so [_{C*P} [quanti libri t_i] C* abbiamo ...
 the-author of-the whom not know-1.SG how-many books had-3.PL
 ... recensito]] è Gianni. (Italian)
 reviewed be-3.SG Gianni

'The author by whom I do not know how many books they had reviewed is Gianni'

- b. *L'autore [_{C*P} del quale_i C* non so [_{C*P} [PP su quanti libri t_i] C* ...
 the-author of-the whom not know-1.SG about how-many books
 ... abbiamo discusso]] è Gianni. (Italian)
 had-3.PL discussed be-3.SG Gianni

'The author by whom I do not know about how many books had discussed is Gianni'

I share Rizzi's judgment: sub-extraction of *del quale* is indeed much worse when it takes place from within a PP than a DP. And, as (159) shows, the same point can actually be made for Spanish:

(159)

- a. **[_{C*P} De qué autor_j C* no sabes [_{C*P} [en cuántas novelas t_j]_i C* ...
 of what author not know-2.SG in how-many novels
 ... el protagonista mata a una chica t_i]]? (Spanish)
 the main-character kill-3.SG to a girl

'Which author don't you know in how many novels by the main character kills a girl?'

- b. **[_{C*P} De qué piloto_j C* no sabes [_{C*P} [PP para qué coche t_j]_i C* han ...
 of what pilot not know-2.SG for what car have-3.PL
 ... diseñado un nuevo motor t_i]]? (Spanish)
 designed a new engine

'Which pilot don't you know for what car of they have designed a new engine?'

The asymmetry raised by Rizzi could be easily explained under the C/ACoE. That is, much like in the case of agreeing objects, indirect objects, and adjuncts, the prepositions in (158) and (159) block agreement, and, consequently, sub-extraction.

This section has investigated whether Torrego's (1985) and Rizzi's (2006) data truly involve sub-extraction. As first argued by Gallego (2005), I have suggested that the

type of sub-extraction we have schematized in (149) is in fact impossible: the judgments in Spanish and Italian are muddled by an interference with a reanalysis of the sub-extracted PP.

6.3. A-bar Systems and the MLC

The previous section was devoted to demonstrate that sub-extraction out of displaced wh-phrases always yields an illicit result –the issue is why.

Putting aside the extraneous role of negation and the *de re* vs. *de dicto* distinction, two concrete possibilities to account for the facts have been considered so far: Gallego & Uriagereka's (2007) *Edge Condition* and Rizzi's (2006; to appear) *criterial Freezing*. Previous sections provided evidence against both accounts: section 3.1. showed that post-verbal subjects (which I took to be in SPEC-*v**) are not opaque, whereas in section 6.2. it was claimed that sub-extraction from SPEC-C* in Romance languages is not real, but a mere “filler-gap” effect.

At the outset of section 6, I noted that here is another candidate to rule out sub-extraction from a complex wh-phrase: Chomsky's (1973) *A-over-A Condition*, repeated as (160) for ease of reference:

(160) **A-OVER-A CONDITION**

If a transformation applies to a structure of the form . . .

[α . . . [A . . .] . . .]

. . . where α is a cyclic node then it must be so interpreted as to apply to the maximal phrase of the type A

[from Chomsky 1977: 85]

What (160) amounts to is that an element of a given type can not cross a syntactic boundary of the same type. Within minimalism, (160) is tacitly subsumed under Chomsky's (1995b) MLC:⁵⁰

⁵⁰ Technically, note that the *A-over-A Condition* is different from the MLC. This is so because, in the first kind of configuration, the elements do not stand in a c-command dependency, but in a dominance (or membership) one. See Müller (2004) for additional qualifications.

(161) MINIMAL LINK CONDITION

K attracts α only if there is no β , β closer to K than α , such that K attracts β

[from Chomsky 1995b: 311]

At first blush, (161) is enough to capture the fact that wh-phrases cannot be extracted out of wh-phrases (recall the configuration in 149 above): under the assumption that matrix v^* , the Probe, bears a [wh]-feature attracting a wh-matching Goal, v^* should not be able to target the most inner wh-determiner by-passing the outer one:⁵¹

(162) [_{C*P} C* [_{TP} T_S [_{v*P} v*_[wh] [_{C*P} [qué_[wh] traducciones [de [qué_[wh] autora]]] C* . . .]]]]

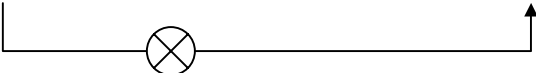

Obviously, for the MLC to properly rule (162) out in case we try to extract *de qué autora* (Eng. *of which author*) out of *qué traducciones de qué autora* (Eng. *which translations by which author*), it must be sensitive to the interrogative nature of wh-words like *what* or *which*. This must be kept in mind, for if the relevant property was a categorial feature (say, D), even (163) would be out:

(163) [_{C*P} Which friend_i C* did [_{TP} you_j T_S [_{v*P} t_j v* see [some pictures [of t_i]]]]]?

A crucial question emerges at this point: do A-bar related features (e.g., [wh], [focus], [topic], etc.) create intervention effects? The literature has devoted much attention to so-called *Superiority* effects within the A-bar realm. The sentence in (164) is a canonical case:⁵²

(164)

a. [_{C*P} Who_i C* [_{TP} t_i T_S [_{v*P} t_i v* said what]]]?

b. * [_{C*P} What_i C* did [_{TP} who_j T_S [_{v*P} t_j v* say t_i]]]?

⁵¹ To account for pied-piping in cases like the ones I have been discussing I must assume that the wh-property can somehow ‘percolate up’ to the preposition. This has an unwelcome consequence, as it makes it impossible for the preposition to ‘shield’ the embedded wh-phrase, and circumvent the noted minimality violation.

⁵² See Boeckx & Grohmann (2003) and references therein.

But it has been noted that intervention is milder if interacting wh-phrases are D-linked:

(165) [_{C*P} Which of your books_i C* has [_{TP} which student_j T_S [_{v*P} t_j v* read t_i]]]?

So the non-trivial issue is what relevant features do and do not count for intervention purposes. Although it has been standardly assumed that wh-phrases contain features capable of triggering intervention, Chomsky (to appear) has recently raised doubts about there being dedicated criterial features (see related discussion in chapter 2; see also Chomsky 2000: 128):

What holds for wh-movement should extend to A'-movement generally. Suppose that the edge-feature of the phase head is indiscriminate: it can seek any goal in its domain, with restrictions [...] determined by other factors [...] Take, say, Topicalization of DP. EF of a phase head PH can seek any DP in the phase and raise it to SPEC-PH. *There are no intervention effects, unless we assume that phrases that are to be topicalized have some special mark. That seems superfluous even if feasible, particularly if we adopt Rizzi's approach to the left periphery: what is raised is identified as a topic by the final position it reaches, and any extra specification is redundant. The same should be true for other forms of A'-movement.*

[from Chomsky to appear: 18 –emphasis added, AJG]

An MLC-based approach to the data is further challenged by the fact that sub-extraction not only fails in the case of complex wh-phrases, it does so also in the case of complex topic and focus phrases.

Consider, for instance, the paradigms in (166) and (167), borrowed from Gallego & Uriagereka (to appear): they are intended to test whether Chomsky's (to appear) claim about edges holds with topicalized and focus-fronted DPs. Notice, in the first place, that presumably there is no MLC issue in these cases, for we are sub-extracting wh-phrases out of topicalized and focus fronted constituents: however, the outcome is still ungrammatical.⁵³

⁵³ I thank José M. Brucart, Teresa Espinal, Jaume Mateu, Carme Picallo, Gemma Rigau, Jaume Solà, and Juan Uriagereka for judgments. In order to avoid filler-gap effects, I use verbs like *parecer* (Eng. *seem*), which disallows aboutness dependents in both Spanish and Catalan. See previous section.

(166) *Wh-Sub-extraction out of topicalized DPs*

- a. * $[_{C^*P}$ De quin escriptor_i C* et sembla $[_{C^*P}$ C* que, [novel.les t_i]_j, ...
of which writer CL-to-you seem-3.SG that, novels,
... n' he llegit moltes t_j]]? (Catalan)
CL-of-them have-1.SG read many

'Which writer does it seem to you that, novels, I have read many (of them)?'

- b. * $[_{C^*P}$ De quin artista_i C* creus $[_{C^*P}$ C* que, [les fotografies t_i]_j, ...
of which artist think-2.SG that, the pictures,
... són horribles t_j]]? (Catalan)
be-3.PL horrible

'Of which artist do you think that, the pictures, are horrible?'

- c. * $[_{C^*P}$ De qué escritor_i C* te parece $[_{C^*P}$ C* que, [las novelas t_i]_j, ...
of what writer CL-to-you seem-3.SG that, the novels,
... lo van a t_j hacer millonario]]? (Spanish)
CL-him go-3.PL to make-INF millionaire

'Which writer does it seem to you that the novels by are going to make him rich?'

- d. * $[_{C^*P}$ De qué pintor_i C* te parece $[_{C^*P}$ C* que, [los cuadros t_i]_j, ...
of what painter CL-to-you seem-3.SG that, the paintings,
... los detesto t_j]]? (Spanish)
CL-them hate-1.SG

'Which painter does it seem to you that the paintings by I hate?'

[from Gallego & Uriagereka to appear: 23]

(167) *Wh-Sub-extraction out of focus-fronted DPs*

- a. * $[_{C^*P}$ De qué escritor_i C* te parece $[_{C^*P}$ C* que [MUCHAS NOVELAS t_i]_j, ...
of what writer CL-to-you seem-3.SG that MANY NOVELS
... leo t_j]] (...y no artículos de opinión) (Spanish)
read-1.SG and not papers of opinion

'Which writer does it seem to you that MANY NOVELS by I read

(...and not editorials)?'

- b. *_{[C*P De qué actor_i C* crees} _{[C*P C* que [FOTOGRAFÍAS t_i]_j colecciono t_j]] . . .}
of what actor think-2.SG that PICTURES collect-1.SG
. . . (... y no autógrafos) (Spanish)
and not autographs

‘Which actor do you believe that PICTURES of I collect (... and not autographs)?’

- c. *_{[C*P De quin escriptor_i C* et} _{sembla [C*P C* que [MOLTES NOVEL·LES t_i] . . .}
of which writer CL-to-you seem-3.SG that MANY NOVELS
. . . s’ han llegit (en aquest país) (Catalan)
CL-SE have-3.PL read (in this country)

‘Which writer does it seem to you that MANY NOVELS by have been read
(in this country)?’

[from Gallego & Uriagereka to appear: 23]

Consider now a similar paradigm, but this time we topicalize and focalize constituents embedded within already topicalized and focus-fronted DPs, respectively:

(168) *Topic-Sub-extraction out of topicalized DPs*

- a. ??_{[C*P De Javier Marías_i, C* me} _{parece [C*P C* que, [las novelas t_i]_j, . . .}
of Javier Marías, CL-to-me seem-3.SG that, the novels,
. . . las han sobrevalorado t_j]] (Spanish)
CL-them have-3.PL overrated

‘Javier Marías, it seems to me that, the novels by, people have overrated them’

- b. *_{[C*P De Scorsese_i, C* me} _{parece [C*P C* que, [películas t_i]_j, . . .}
of Scorsese CL-to-me seem-3.SG that, movies,
. . . aún no he visto t_j]] (Spanish)
yet not have-1.SG seen

‘Scorsese, it seems to me that, novels by, I have not seen yet’

[from Gallego & Uriagereka to appear: 24]

(169) Focus-Sub-extraction out of focus-fronted DPs

- a. * $[_{C^*P} \text{ DE MARÍAS}_i \text{ C}^* \text{ me}$ parece $[_{C^*P} \text{ C}^* \text{ que } [_{\text{LAS NOVELAS } t_i}]_j \dots$
 OF MARÍAS, CL-to-me seem-3.SG that, THE NOVELS,
 ... han sido sobrealoradas t_j]] (Spanish)
 have-3.PL been overrated

‘MARÍAS, it seems to me that NOVELS BY have been overrated’

- b. * $[_{C^*P} \text{ DE SCORSESE}_i \text{ C}^* \text{ me}$ parece $[_{C^*P} \text{ C}^* \text{ que } [_{\text{PELÍCULAS } t_i}]_j \dots$
 OF SCORSESE CL-to-me seem-3.SG that MOVIES
 ... aún no he visto t_j]] (Spanish)
 yet not have-1.SG seen

‘SCORSESE it seems to me that MOVIES BY I have not seen yet’

[from Gallego & Uriagereka to appear: 24]

Let us concentrate on (168), the topicalization case. As can be seen, the examples are ungrammatical, but this is puzzling: it is a well-known fact about Romance languages that they do not show Superiority effects with topicalized constituents (see 170) –so why should topicalization of a constituent within an already topicalized constituent yield an illicit result?⁵⁴

(170)

- a. $[_{C^*P} \text{ Juan}_i, [\text{ a } \text{ María}_j, [\text{ los libros}_z, \text{ C}^* [_{\text{TP}} \text{ se los dio } [_{v^*P} t_i t_j t_z \text{ el martes}]]]]]]$
 Juan to María the books, CL-to-her CL-them give-PAST-3.SG the Tuesday
 ‘Juan, to María, the books, he gave them to her on Tuesday’

- b. $[_{C^*P} \text{ A } \text{ María}_j, [\text{ los libros}_z, [\text{ Juan}_i, \text{ C}^* [_{\text{TP}} \text{ se los dio } [_{v^*P} t_i t_j t_z \text{ el martes}]]]]]]$
 to María the books, Juan CL-to-her CL-them give-PAST-3.SG the Tuesday
 ‘To María, the books, Juan, he gave them to her on Tuesday’

- c. $[_{C^*P} \text{ Los libros}_z, [\text{ Juan}_i, [\text{ a } \text{ María}_j, [_{\text{TP}} \text{ se los dio } [_{v^*P} t_i t_j t_z \text{ el martes}]]]]]]$
 the books, Juan to María, CL-to-her CL-them give-PAST-3.SG the Tuesday
 ‘The books, Juan, to María, he gave them to her on Tuesday’

⁵⁴ In order to account for the absence of intervention effects in cases like these, Rizzi (2004) suggests that topics can target the same projection so that they become equidistant, in Chomsky’s (1993a; 1995b; 2000) sense.

- d. [_{C^{*P}} Los libros_{S_Z}, [a María_i, [Juan_i, [TP se los dio [_{v^{*P}} t_i t_j t_z el martes]]]]]]
 the books, to María, Juan CL-to-her CL-them give-PAST-3.SG the Tuesday
 ‘The books, to María, Juan, he gave them to her on Tuesday’

[from Gallego & Uriagereka to appear: 24]

As (171) shows, the facts also hold in Italian.

- (171) L’ anno prossimo, in questo modo, le elezioni, senza troppe, ...
 the year next, in this way, the elections, without much
 ... difficoltà, a Gianni, potreste farglielo vincere. (Italian)
 trouble, to Gianni, could-2.SG make-INF-CL-to-him win-INF
 ‘Next year, in this way, the elections, without trouble, to Gianni, you could make
 him win them’

[from Rizzi 2004: 246]

The puzzle is, to repeat, why sub-extraction is bad in (168), if no MLC conflicts arise in Romance topicalization, as (170) and (171) show.

In this chapter I have considered some options to rule out sub-extraction out of wh-moved constituents. Once the *Edge Condition* and *Criterial Freezing* haven been discarded, I have explored whether Chomsky’s (1995b) MLC (the current counterpart of Chomsky’s 1973 *A-over-A Condition*) could be the key. Although this mechanism does provide a way of preventing sub-extraction of the paradigm we are considering, I have dismissed it because it forces us to entertain intervention effects within the A-bar system, unlikely for the sorts of cases and languages we have examined.⁵⁵

⁵⁵ Feature-based approaches to A-bar dependencies also raise empirical concerns: evidence indicates that A'-intervention is not cross-linguistically stable. Spanish, for instance, shows almost negligible Superiority effects, as noted by many (see Ordóñez 1998b, Uribe-Etxebarria 1992, and references therein):

- (i) [_{C^{*P}} Quién_i C* compró [_{v^{*P}} t_i v* qué]]? (Spanish)
 who buy-PAST-3.SG what
 ‘Who bought what?’
 (ii) (?) [_{C^{*P}} Qué_i C compró [_{v^{*P}} quién v* t_i]]? (Spanish)
 what buy-PAST-3.SG who
 ‘What did who bought?’

More precisely, in my proposal, sub-extraction of *of whom* in both (172a) and (172b) must be performed (to put in Chomsky’s terms) by an edge-Probe which is immune to Match, and hence cannot trigger standard intervention effects:

(172)

- a. [_{C*P} C* [_{TP} Mary_i T_S [_{v*P} t_i bought v* [a picture [of whom]]]]]
 b. John v* wonders [_{C*P} [which picture [of whom]]_j C* [_{TP} Mary_i T_S [_{v*P} t_i bought v* t_j]]]

The data above raise the question of why (172b), but not (172a), is out –it should be fine, if edge-Probes are indiscriminate, as Chomsky (to appear) contends. This must follow, as we argue in Gallego & Uriagereka (to appear), from a merely configurational fact: the *wh*-phrase occupies a phase edge in (172b), but not in (172a).

The conclusion is further reinforced by (173), where the complex *wh*-phrase remains *in situ*, away from any edge (thanks to Marc Richards for his judgments):

(173)

- a. ?[_{C*P} Who_i C* did [_{TP} you T_S [_{v*P} t_j v* buy [what pictures of t_i]]]]?
 b. [_{C*P} Which actress_i C* did [_{TP} you T_S [_{v*P} t_j v* buy [which pictures of t_i]]]]?

Observe also (174), uttered after *I saw Renoir’s and Monet’s portrait of one another, and Picasso’s and Braque’s too*.

(174) Ah, so [_{C*P} who_i C* did [_{TP} you_j T_S [_{v*P} t_j buy [whose portrait of t_i]]]]?

Yet again, Spanish behaves in a similar fashion, as (175) shows:⁵⁶

(175) ?[_{C*P} De qué pintor_i C* has comprado [_{v*P} pro v* [qué cuadros t_i]]]? (Spanish)
 of what painter have-2.SG bought pro what paintings
 ‘Which painter have you bought paintings by?’

Let us put all the pieces together. In the previous section we saw how examples of the kind Lasnik & Saito (1992), Rizzi (2006), and Torrego (1985) provided are

⁵⁶ Setting aside echo contexts, (175) is fine only under a pair-list reading.

systematically ruled out (in the case of Romance this becomes clear when aboutness dependents are controlled for) –but we did not say why.

The *A-over-A Condition*/MLC is the first candidate that comes to mind, as it instantiates a minimality scenario which nicely fits the patterns we are considering. Be that as it may, I have followed the solution put forward by Gallego & Uriagereka (to appear), arguing that the grounds to adopt intervention effects within the A-bar system are dubious, empirically and conceptually. Consequently, we appear to be left with Chomsky’s (to appear) analysis, which basically posits a computational problem on phase edges.

Although appealing, such a possibility is unsatisfactory, given its non-homogeneous status: the v^*P edge appears to pose no locality constraint in languages like Dutch and Spanish, as post-verbal subjects show no CED effect. In order to overcome this tension I will follow Gallego & Uriagereka (to appear) in modifying Rizzi’s (2006; to appear) *Criterion Freezing*, whose final formulation is repeated below for convenience:

(176) **CRITERIAL FREEZING (final version)**

[Only t]he Criterial Goal is frozen in place

[from Rizzi to appear: 2]

As argued in the previous section, an accurate analysis of Torrego’s (1985) data argues against (176), but this does not entail that the notion of freezing that Rizzi (2006; to appear) invokes is to be rejected. In particular, Gallego & Uriagereka (to appear) suggest that the non-final version of Rizzi’s (2006; to appear) *Criterion Freezing* is what correctly captures the facts:

(177) **CRITERIAL FREEZING (non-final version)**

A phrase meeting a criterion is frozen in place

[from Rizzi 2006: 112]

(177) is saying that the entire XP (not just a subpart) meeting a criterion is frozen in place. This is all we need to capture not only Torrego’s (1985) paradigm, but also the

extended paradigm that this section has paid attention to. By (177), XP is handed to the semantic component, and thus rendered out-of-sight for computational processes like sub-extraction.⁵⁷

But even if one wants to embrace (177), I still consider Rizzi's (2006; to appear) implementation problematic on technical grounds, as it builds on the checking of (semantic) features that, though empirically undeniable, has a dubious computational status (see chapter 2). Interestingly, Rizzi's (2006; to appear) *Criterion Freezing* is, for all intents and purposes, virtually equivalent to (178), Chomsky's (2001) discourse-oriented semantics assigning mechanism:

(178) The EPP position of a phase *Ph* is assigned Int

[from Chomsky 2001: 33]

From the perspective of (178), XPs that have undergone movement are assigned an interpretation: not because of feature checking, but because of the configuration they take part in.

If I read Chomsky (2001; to appear) correctly, he is suggesting a configurational approach to the *Left Periphery*, analogous to Hale & Keyser's (2002) view for argument structure: just like a DP is interpreted as an "Agent" or a "Theme" because it belongs to a particular configuration within the *v**P, a DP should be interpreted as a "Topic" or a "Focus" by the particular position it occupies in the C*P.

The proposed analysis is consistent with the account of the *Subject Condition* in that both kinds of sub-extraction restrictions follow from a freezing effect that is independent of phase edges. I must nonetheless admit that, as it stands, (178)'s formulation is still dependent on the notion of *edge*. Chomsky's (2001; to appear) framework, as a matter of fact, only warrants discourse-oriented semantics if a phase edge is involved –a problem that vanishes if, as argued in chapter 2, every application of internal Merge can give rise to interpretive effects.

⁵⁷ The logic of (178) is somewhat in the spirit of Uriagereka's (1999a) *Multiple Spell-Out*, but it capitalizes on semantic rather than phonological Transfer. Although coherent, it remains to be completely understood why a freezing effect that takes place at the SEM component has such an impact on computational operation like sub-extraction.

7. Remaining Issues: the *Subject Condition* (a reply to Fortuny 2007)

Sections 3 and 6 reproduced the discussion in Gallego & Uriagereka (2007; to appear) with respect to sub-extraction from different types of dependents: subjects, objects, adjuncts, and displaced constituents. In this final section I want to reassess sub-extraction from subjects (EAs), considering some of the observations made by Jordi Fortuny in Fortuny (2007).

Among all the varieties of sub-extraction considered here, it is Huang's (1982) *Subject Condition* that deserves particular attention: both because of its controversial status and because it is one case in which phasal specifiers (so-called *edges*) are involved. Recall that, according to Chomsky (to appear), these positions pose a locality problem related to -it would appear- depth of embedding. This claim was illustrated with (179):

(179)

- a. *[_{C*P} Of which car_i C* did [_{TP} [the driver t_i]_j T_S [_{v*P} t_j v* cause a scandal]]])?
 b. [_{C*P} Of which car_i C* was [_{TP} [the driver t_i]_j T_S [_{vP} v awarded t_j a prize]]])?

[from Chomsky to appear: 14]

Following the discussion of Gallego & Uriagereka (2007), pairs like the one in (180) were invoked to support an analysis attributing the sub-extraction failure to the Case/agreement systems:

(180) [_{C*P} De qué conferenciantes_i C* te parece que . . . (Spanish)

of what speakers CL-to-you seem-3.SG that

- a. . . . (?) [_{TP} T_S me_z van a impresionar_v [_{v*P} [las propuestas t_i] v* t_z t_v]])?

CL-to-me go-3.PL to impress-INF the proposals

- b. . . . * [_{TP} [las propuestas t_i]_j T_S me_z van a impresionar_v [_{v*P} t_j v* t_z t_v]])?

the proposals CL-to-me go-3.PL to impress-INF

'Which speakers does it seem to you that the proposals by will impress me?'

[from Uriagereka 1988a: 118]

Fortuny (2007) addresses this analysis at length, arguing in favor of Chomsky’s (to appear) phase-based account of CED effects.⁵⁸ Consequently, Fortuny (2007) denies the possibility for post-verbal subjects in Spanish to be transparent, suggesting that different factors conspire to make sub-extraction in (180) possible. Broadly, Fortuny (2007) emphasizes the following aspects of Gallego’s (2005) and Gallego & Uriagereka’s (2007; to appear) analyses:

(181)

- a. The status of the sub-extracted PP
- b. The base structure of psych-predicates

Gallego (2005) discusses two main structural scenarios, depending upon sub-extraction is *intra-clausal* (within the same clause) or *trans-clausal* (across clauses).

(182)

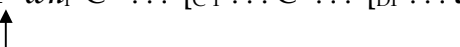
- a. $[_{C^*P} PP-wh_i C^* \dots [DP \dots t_i]]$ *intra-clausal sub-extraction*

- b. $[_{C^*P} PP-wh_i C^* \dots [_{C^*P} \dots C^* \dots [DP \dots t_i]]]$ *trans-clausal sub-extraction*

Consider the intra-clausal scenario first, where sub-extraction is (for unclear reasons) bad. This is in fact an observation due to Uriagereka (1988a):

⁵⁸ One clarification comment is in order. Fortuny (2007) bases his argumentation on the analysis put forward in Gallego (2005) (cited by Fortuny 2007 as Gallego 2006). Contrary to the account entertained in this thesis, in Gallego (2005) I assumed a phase-based analysis of sub-extraction, taking sub-extraction from subjects in Spanish to be possible when these remain *in situ*, in SPEC-*v**, because of *Phase Sliding*.

Although the technical analysis is thus different, both Gallego (2005) and Uriagereka & Gallego (2007a) make the same point (which was, in fact, an original observation of Uriagereka’s 1988a): it is sub-extraction from SPEC-T_S (not SPEC-*v**) that yields an illicit outcome.

In this section, I will reply Fortuny’s (2007) counter-analysis largely ignoring what the specific analysis of the *Subject Condition* may turn out to be: what I am concerned with is showing that Fortuny’s (2007) objections do not prove the preverbal vs. post-verbal asymmetry of Uriagereka’s (1988a) wrong.

(183) ??[_{C*P} De qué artistas_i C* han herido [_{TP} T_S [_{v*P} tu sensibilidad_j
of what artists have-3.PL hurt your sensitivity
... [_{v*P} [las obras t_i] v* t_j]]]]? (Spanish)
the works
‘Which artists have the works of hurt your sensitivity?’

[from Uriagereka 1988a: 122]

Together with (183), which is degraded, Gallego (2005) provided the next example to show that sub-extraction is worse if the subject occupies a non-final position:

(184) *[_{C*P} De qué artistas_i C* han herido [_{TP} [las obras t_i] T_S [_{v*P} t_j v* ...
of what artists have-3.PL hurt the works
... tu sensibilidad]]]? (Spanish)
your sensitivity
‘Which artists have the works of hurt your sensitivity?’

Assuming the verb moves to C*, Gallego (2005) argued that the subjects in (184) and (185) occupy different positions: SPEC-v* and SPEC-T_S respectively. If the latter is the problematic position for sub-extraction processes, the contrast in (183)-(184) follows.

Fortuny (2007) casts doubt on Gallego’s (2005) hypothesis on empirical grounds, arguing that adverb position and subject-object order are not good evidence to identify the subject’s position in (183)-(184). As Fortuny (2007) notes, the subject-object vs. object-subject asymmetry can arise in declarative sentences too:

(185)
a. Han herido las obras de Pedro tu sensibilidad. (Spanish)
have-2.PL hurt the works of Pedro your sensibility
‘The works by Pedro have hurt your sensibility’
b. Han herido tu sensibilidad las obras de Pedro. (Spanish)
have-2.PL hurt your sensibility the works of Pedro
‘The works by Pedro have hurt your sensibility’

[from Fortuny 2007: 111]

Fortuny (2007) then adds that “[s]ince claiming that V raises to C in Spanish assertive clauses would be entirely stipulative, the subject *las obras de Pedro* may be in a position lower than T even if it precedes the object *tu sensibilidad*.” (p.111). In other words: in both (185b) and (184) it is not obvious that the subject occupies SPEC-T_S. I agree with Fortuny (2007) in that the post-verbal subjects in (185) remain below T_S –in fact, they do under the analysis of chapter 3,⁵⁹ but this, without any further qualification, is not direct evidence as to whether the same carries over to the pair in (183)-(184).

Still within the intra-clausal pattern, Fortuny (2007) considers the minimal pair in (186), from Gallego (2005):

(186)

- a. ??[_{C*P} De qué universidad_i C* te causaron [los estudiantes t_i] . . .
of what university CL-to-you cause-PAST-3.PL the students
. . . problemas]? (Spanish)
problems
‘Of which university did the students cause problems?’
- b. [_{C*P} De qué universidad_i C* te causaron problemas . . .
of what university CL-to-you cause-PAST-3.PL problems
. . . [los estudiantes t_i]]? (Spanish)
the students
‘Of which university did the students cause problems?’

[from Gallego 2005: 86]

Note that the situation in (186) is not much different from the one in (183)-(184): sub-extraction is better (almost perfect) if the subject occupies a final position.

Sub-extraction from subjects seems to be possible in the following cases too:

⁵⁹ Fortuny (2007) concludes that the subject in (186a) and (186b) occupies the same position: SPEC-*v**. The analysis is virtually identical to the one I put forward in chapter 3, but it differs in the way the subject comes to occupy SPEC-*v**: by external Merge or internal Merge. For a different perspective, see Ordóñez (2005).

(187)

- a. (?)_{[C*P De qué equipo_i C* han protestado [muchos jugadores t_i]]}? (Spanish)
of what team have-3.PL protested many players
‘Which team have the/much players of protested?’
- b. (?)_{[C*P De qué universidad_i C* te respetan [muchos estudiantes t_i]]}? (Spanish)
of what university CL-you respect-3.PL many students
‘Which university do many students of respect you?’
- c. ?_{[C*P De qué actor de cine_i C* causaron sensación [las fotografías t_i]]}? (Spanish)
of what actor of cinema cause-PAST-3.PL sensation the pictures
‘Which actor did the pictures of caused sensation?’

Fortuny (2007) agrees with the judgments, but he relates the acceptability of these data to an independent factor: the status of the sub-extracted PP. Following Chomsky (to appear), Fortuny (2007) takes the sub-extracted PPs in almost all the previous cases to be not arguments, but reduced relatives. This intriguing reanalysis is particularly productive in the case of *picture*-DPs, which, according to Chomsky (to appear), are not good candidates to run sub-extraction tests.

In the oral tradition, including talks of mine, examples have kept to “picture-PP,” but that lexical choice introduces extraneous issues because of the ambiguity of the phrase, which can be understood with PP interpreted not as a complement of “picture” but as, in effect, a reduced relative clause (roughly, “I have a picture which is of Boston,” contrary to “I saw a driver who is of the car,” [*]“I saw an author who is of the book”) [from Chomsky to appear: 13 fn. 38]

Fortuny (2007: 113) proposes the structural contrast in (188) to capture this difference:

(188)

- a. [DP PP] *symmetric structure (reduced relative)*
- b. [DP [PP]] *nested structure (argument)*

If I interpret this correctly, Fortuny’s (2007) claim amounts to there being no sub-extraction in the instances so far considered. More to the point, the DPs from which sub-extraction takes place in both Uriagereka’s (1988a) and Gallego’s (2005) examples can be given a reduced relative paraphrase: *las propuestas que son de los conferenciantes*

(Eng. *the proposals which are of the speakers*), *las obras que son del artista* (Eng. *the works which are of the artist*), and *los estudiantes que son de la universidad* (Eng. *the students which are of the university*). That such a paraphrase is possible raises the possibility for there being no sub-extraction.

A similar (yet more radical) conclusion is reached by Broeckhuis (2005: 4), who takes the alleged sub-extracted PP of Chomsky’s (to appear) examples to be “not [...] a complement or a modifier of the noun, but rather [...] an independent adverbial phrase.”

There are grounds, however, to be skeptical about this possibility. First, it is not clear at all whether the argument vs. adjunct distinction within the DP can be compared to the one within the clause.^{60 61} Second, Fortuny’s (2007) idea seems to go against the well-known fact that it is impossible to sub-extract adjunct PPs out of DPs (see Chomsky 1986a, Culicover & Rochemont 1982, and Lasnik & Park 2003):

(189)

- a. [_{C*P} Who_i C* do you like [a picture of t_i]]? *argument sub-extraction*
 - b. * [_{C*P} Which table_i C* did you like [a book [on t_i]]]? *adjunct sub-extraction (stranding)*
 - c. * [_{C*P} On which table_i C* did you like [a book t_i]]? *adjunct sub-extraction (pied-piping)*
- [from Ticio 2005: 243]

Granted, one could still argue that reduced relatives are a species of secondary predication, ultimately differing from adjuncts (which is not straightforward, if relative

⁶⁰ To complicate things, Ticio (2005) shows that some varieties of adverbial PPs (roughly, those introduced by the preposition *de* -Eng. *of*) behave like arguments as far as sub-extraction is concerned:

- (i) * [_{C*P} Para quién_i C* robaron [varios regalos t_i]]? (Spanish)
 for whom steal-PAST-3.PL several gifts
 ‘For whom did they steal several gifts?’
- (ii) [_{C*P} De dónde_i C* conocimos [varias chicas t_i]]? (Spanish)
 of where know-PAST-1.PL several girls
 ‘Of where did we meet several girls?’

[from Ticio 2005: 243]

⁶¹ Note, for instance, that any kind of DP-internal dependent is introduced by a preposition, so one cannot rely on this indication in order to determine its status. When it comes to the argument vs. adjunct distinction within the DP most tests I know of are in fact related to semantic intuitions that are hard to translate into formal terms. See Mateu (2002), Pesetsky & Torrego (2004), Ticio (2005), among many others.

clauses are analyzed as adjuncts; see Bianchi 1999). Though plausible, this solution would fall short of explaining why DP-secondary predicates cannot precede the full DP, if they do not occupy an embedded position to begin with (a topic-like reading for the PP must be put aside in 190b):⁶²

(190)

- a. [Las propuestas] [de Chomsky y Kayne] me impresionarán. (Spanish)
the proposals of Chomsky and Kayne CL-to-me impress-FUT-3.SG
‘The proposals by Chomsky and Kayne will impress me’
- b. *[De Chomsky y Kayne] [las propuestas] me impresionarán. (Spanish)
of Chomsky and Kayne the proposals CL-to-me impress-FUT-3.SG
‘The proposals by Chomsky and Kayne will impress me’

But even if all these problems can be overcome, and Chomsky’s (to appear) observation with respect to the status of the sub-extracted PP is correct, it is nevertheless the case that sub-extraction from post-verbal subjects can take place in Spanish: as Uriagereka (1988a) first observed, the result is degraded in intra-clausal environments, but it is still marginally possible. This is shown in (191), where the reduced relative paraphrase is impossible:⁶³

- (191) ??[_{C*P} De qué coche_i C* ha ganado ya dos carreras [el piloto t_i]? (Spanish)
of what car have-3.SG won already two races the pilot
‘Of which car has the driver won two races?’

Typically, questions like (191) are better formulated as in (192), invoking a heavy pied-piping strategy:

- (192) ?[_{C*P} El piloto de qué coche_i C* ha ganado ya dos carreras t_i]? (Spanish)
the pilot of what car have-3.SG won already two races
‘The driver of which car has already won two races?’

⁶² As far as I can tell, the same restriction holds in the case of restrictive and appositive relative clauses. Things depend on how much reduced relatives differ from regular relative clauses.

⁶³ To make (191) better, the reader should imagine a context where someone heard that there is a pilot that has already won two races (say, *Monte Carlo* and *Magny Cours*). In such a situation, one may be curious as to which car that pilot was driving (e.g., Renault, McLaren-Mercedes, Ferrari, etc.).

Again, note that when the subject occupies a non-final position, sub-extraction is worse, for reasons that I fail to see:

- (193) *[_{C*P} De qué coche_i C* ha ganado [el piloto t_i] ya dos carreras]? (Spanish)
of what car have-3.SG won the pilot already two races
‘Of which car has the driver won two races?’

So far I have concentrated on the first issue explored by Fortuny (2007) –namely, the status of the sub-extracted PP. The second concerns cases of trans-clausal sub-extraction, like Uriagereka’s (1988a) minimal pair, repeated here for convenience:

- (194) [_{C*P} De qué conferenciantes_i C* te parece que . . . (Spanish)
of what speakers CL-to-you seem-3.SG that
a. . . . (?) [_{TP} T_S me_z van a impresionar_v [_{v*P} [las propuestas t_i] v* t_z t_v]] ?
CL-to-me go-3.PL to impress-INF the proposals
b. . . . * [_{TP} [las propuestas t_i]_j T_S me_z van a impresionar_v [_{v*P} t_j v* t_z t_v]] ?
the proposals CL-to-me go-3.PL to impress-INF
‘Which speakers does it seem to you that the proposals by will impress me?’
[from Uriagereka 1988a: 118]

As Fortuny (2007) acknowledges, the contrast here is much stronger, (194a) being almost perfect. This time, Fortuny (2007) relates the asymmetry in (194) to the position occupied by the subjects of psych predicates.

Once again, this has to do with an observation by Chomsky (to appear), who notes that sub-extraction in (195a) may be better than in (195b) (he does not say how much better, but let us assume a ? vs. * contrast):

- (195)
a. ? [_{C*P} Of which books_i C* did [_{TP} [the author t_i] T_S [_{v*P} t_j v* receive the prize]]] ?
b. * [_{C*P} Of which car_i C* did [_{TP} [the driver t_i] T_S [_{v*P} t_j v* cause a scandal]]] ?

Chomsky (to appear) suggests that the difference between *receive* and *cause* is a consequence of the flavor of v^* , but he does not elaborate on how such a (featural/semantic) difference affects sub-extraction. Fortuny (2007) does, arguing that the subject of *impresionar* (Eng. *impress*) is generated in an object base position, like any /Theme/ (more accurately, in the *search domain* of v^* , as Fortuny qualifies through personal communication):

(196)

- a. [v^* P [the driver of which car] v^* [$_{VP}$ cause a scandal]] ('cause')
- b. [v^* P v^* [$_{VP}$ [the proposals by which speakers] [$_{V'} V$ GOAL]]] ('impress')
- [from Fortuny 2007: 116]

Although he is not explicit about it, Fortuny (2007) seems to tacitly adopt Belletti & Rizzi's (1988) hypothesis that Object-Experiencer verbs have an unaccusative structure.^{64 65} Under that analysis, the /Theme/ of Object-Experiencer verbs originates in a position lower than the /Experiencer/'s -or /Goal/'s, according to Fortuny's (2007) analysis:

(197) *Belletti & Rizzi's (1988) Analysis*

a. *John frightens them (Obj-Exp)*

b. *They fear John (Subj-Exp)*

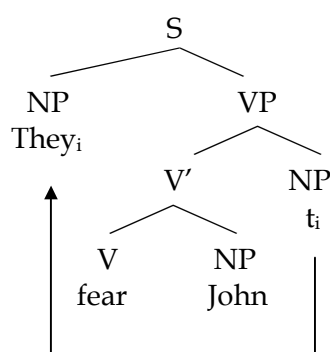
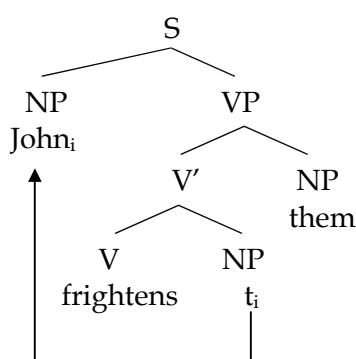

[from McGinnis 2002: 117]

⁶⁴ Exploring the intricacies posed by psych-predicates goes beyond the scope of this thesis. What I want to show here is something more specific: I want to argue that the base position of the subject of Object-Experiencer verbs does not correspond to the base position of objects.

⁶⁵ This possibility can only be entertained in the case of Object-Experiencer verbs (e.g., *frighten*, *disgust*, *amuse*, etc.). As pointed out in the literature (see Arad 1998; 2002 and references therein), Subject-Experiencer verbs (e.g., *fear*, *like*, *adore*, etc.) and Object-Experiencer verbs with an active reading pattern with regular transitives. See below.

Several authors (see Arad 1998; 2002, McGinnis 2000, Pesetsky 1995, and references therein for discussion), however, have argued against an unaccusative analysis for Object-Experiencer verbs.⁶⁶ Hale & Keyser (2002), for instance, dispense with the distinction in (197), positing the same locatum configuration for both types of psych-predicates. This is pictured in (198), where the base position of objects is not occupied by the subject:

(198)

a. *We respect the truth* (Subj-Exp)

b. *The truth angers politicians* (Obj-Exp)

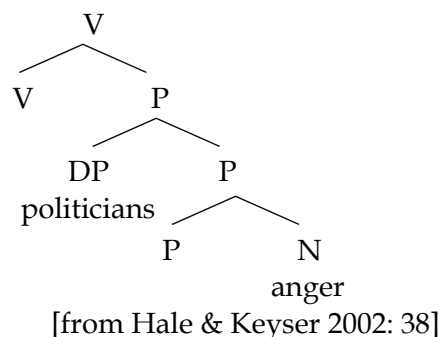
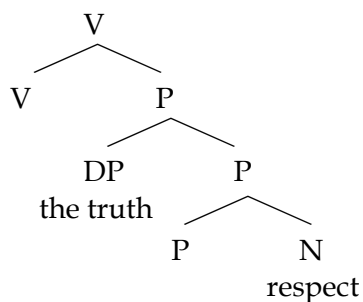

However, as it stands, (198) does not help much either, because it does not say where subjects are –Hale & Keyser’s (2002) work generally puts this issue aside.

Arad (1998; 2002) provides a more comprehensive analysis of psych-predicates. According to this author, Object-Experiencer verbs are ambiguous with respect to a stative and a non-stative reading:⁶⁷

⁶⁶ As highlighted by McGinnis (2000), the unaccusative analysis of Belletti & Rizzi (1988) is problematic if the MLC is seriously entertained: the lower DP should not be able to bypass the Experiencer –unless it ‘leapfrogs.’

A well-known reason to pursue the analysis in (195) comes from backward binding effects, which are displayed by Object-Experiencer verbs:

- (i) Each other_i’s outbursts frightened Marx and Hegel_i *Object-Experiencer V*
 - (ii) *Each other_i’s mothers love Bill and Hank_i *Subjec-Experiencer V*
- [from Hale & Keyser 2002: 179]

See Pesetsky (1995: 42-53 and 201-203) and Hale & Keyser (2002: 178-185) for arguments against an unaccusative analysis for Object-Experiencer verbs to account for backward binding.

⁶⁷ Arad (2002) argues that the difference has nothing to do with *causativity*: under both stative and non-stative readings, the psych-verb is causative:

(199)

- a. Anna frightened Laura deliberately. *Obj-Exp (agentive reading)*
 b. Anna's behavior frightens Laura. *Obj-Exp (stative reading)*

[from Arad 2002: 20]

As Arad (2002) shows, the distinction also has formal consequences: in agentive readings, the verb behaves as a standard transitive, assigning accusative Case; in stative readings, the verb assigns dative Case. This can be seen in languages like Spanish (see Franco 1990 for discussion):

(200)

- a. La música {*/la/le} molestó. (Spanish)
 the music CL- $\{her_{ACC}/her_{DAT}\}$ bother-PAST-3.SG
 'The music bothered her'
 b. Juan {la/le} molestó. (Spanish)
 Juan CL- $\{her_{ACC}/her_{DAT}\}$ bother-PAST-3.SG
 'Juan bothered her'

[adapted from Arad 2002: 22]

Facts like these (and more) lead Arad (2002) to conclude that the only variety of psych-predicate that displays a special behavior is that of Object-Experiencer verbs with a stative reading. In order to account for this idiosyncrasy, Arad (2002) argues that light verbs can come into different flavors:

Suppose that heads introducing external arguments could belong to more than one type. Specifically, in the case of ObjExp verbs, this head could be agentive or stative. We can then explain the two readings of ObjExp verbs by assuming the root $\sqrt{\text{fright}}$ can combine with two types of verbal heads, which introduce an agentive or a stative external argument [...]

[from Arad 2002: 23]

Active causation involves an agent. Who acts and brings about a change of state, while *stative causation* involves a stative causer (or a stimulus) which triggers a state (whose existence is co-extensive with that of the stimulus).

[from Arad 2002: 21]

See Hale & Keyser (2002: ch. 7) for the idea that stativity is related to the presence of a central coincidence P in the sub-lexical structure of (verbal) predicates.

Arad (2002) calls this light verb “stative little *v*,” and attributes it the following properties:

[...] first, it gives the event the interpretation of stative causation (unlike standard little *v*, which is active). Second, the argument in its specifier is interpreted as a stative cause. Finally, its object is marked with dative case (cf. Spanish) rather than accusative [from Arad 2002: 24]

The structure of verbs like *impresionar* (Eng. *impress*), according to Arad (2002), would therefore be as in (201b). The important thing to notice is that the subject is not generated in the canonical object position: it is a *bona fide* specifier of a light verb.⁶⁸

(201)

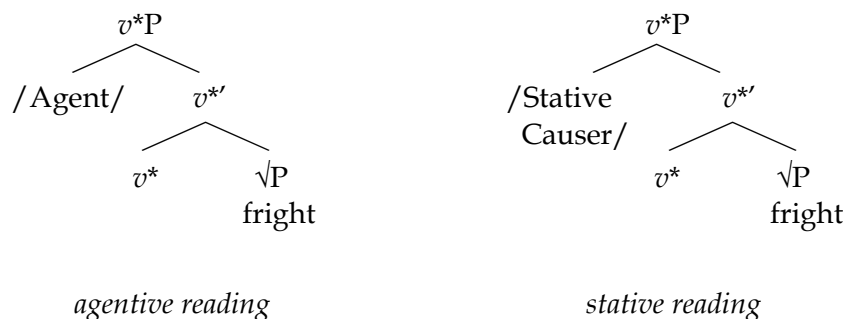

[adapted from Arad 2002: 24]

If this much is tenable, then the essence of Fortuny’s (2007) objection is weakened: the subject of Uriagereka’s (1988a) example does qualify as a specifier.

In addition, note that *impresionar* (Eng. *impress*) allows for ‘resultative passivization,’ which I take as evidence that the active version assigns accusative in the stative reading –being thus ϕ -complete:

(202) Juan quedó impresionado por las propuestas de Chomsky. (Spanish)
 Juan get-PAST-3.SG impressed by the proposals of Chomsky
 ‘Juan got impressed by Chomsky’s proposals’

Differently put, the possibility for *impresionar* (Eng. *impress*) to passivize is strong evidence that it qualifies as a full-fledged transitive verb, assigning accusative Case (and not necessarily dative, *as per* Arad 2002) in its active version. The example in (203)

⁶⁸ See McGinnis (2000) for a similar analysis.

reinforces this conclusion, as the object clitic receives accusative Case even if the subject does not yield an agentive reading:

- (203) Los cuadros de Picasso lo impresionaron profundamente. (Spanish)
 the paintings of Picasso CL-him_{ACC} impress-PAST-3.PL deeply
 ‘Picasso’s paintings deeply impressed him’

In sum, evidence strongly indicates that the subject of *impresionar* (Eng. *impress*) is, for all intents and purposes, the specifier of a ϕ -complete v^* . Consequently, there is no relevant formal asymmetry between the configurations that subjects of verbs like *impress* or *cause* occupy: both stand in phase edges.

To conclude my reasoning I would like to reproduce Uriagereka’s (1988a) examples introducing a slight modification. In order to avoid a reduced relative reanalysis, suppose the subject is *el escritor de qué novela* (Eng. *the writer of which novel*), which disallows the paraphrase **el escritor que es de la novela* (Eng. *the writer who is of the novel*):

- (204) [_{C*P} De qué novela_i C* te parece que ... (Spanish)
 of what novel CL-to-you seem-3.SG that
 a. ... (?) [_{TP} T_S me_z va a impresionar_v [_{v*P} [el escritor t_i] v* t_z t_v]]?
 CL-to-me go-3.PL to impress-INF the writer
 b. ... * [_{TP} [el escritor t_i]_j T_S me_z va a impresionar_v [_{v*P} t_j v* t_z t_v]]?
 the writer CL-to-me go-3.SG to impress-INF
 ‘Of which novel does it seem to you that the writer will impress me?’

To my ear, the contrast is basically the same, even if we use a non-psych verb, like *causar* (Eng. *cause*):

- (205) [_{C*P} De qué novela_i C* te parece que ... (Spanish)
 of what novel CL-to-you seem-3.SG that
 a. ... ? [_{TP} T_S ha causado más escándalos [el escritor t_i]]?
 have-3.SG caused more scandals the writer

b. . . . *_{[TP [el escritor t_i]; T_S ha causado más escándalos t_j]]?}
 the writer have-3.SG caused more scandals

‘Of which novel does it seem to you that the writer caused more scandals?’

From these facts, I conclude that Fortuny’s (2007) analysis of psych verbs as having their subjects generated in the base position for canonical objects cannot be maintained: these are generated as regular specifiers of a light verb that can assign accusative (Arad’s 2002 “stative *v**”).

I hasten to add that, as already noted by Uriagereka (1988a), sub-extraction from subjects is much better when it takes place from an embedded clause. I therefore agree with Fortuny (2007) that intra-clausal sub-extraction is more degraded, for reasons I do not understand. Perhaps intra-clausal sub-extraction improves if a psych-verb like *escandalizar* (Eng. *shock*) is used:

(206) ?_{[C*P De qué novela naturalista_i C* [TP T_S te ha escandalizado . . .}
 of what novel naturalist CL-you have-3.SG shocked
 . . . más [el autor t_i]]: *La Regenta* o *Los pazos de Ulloa*? (Spanish)
 more the author *La Regenta* or *Los pazos de Ulloa*?

‘Of which naturalist novel has the author shocked you the most?’

In the light of examples like (206) and (193a) it might be worth investigating whether the particular ‘flavor’ of psych light verbs has any ameliorating effect, as Chomsky (to appear) speculates: if so, one would have to find out why a non-configurational aspect (like the featural specification of light predicates) is relevant for sub-extraction.⁶⁹

⁶⁹ Putting aside Arad’s (2002) analysis in (201), Jaume Mateu observes through personal communication that flavors can indeed be expressed by configurational means. So, for instance, he informs me that the flavor *become* is typically encoded by (verbal) dyadic structures, like (i):

(i) _{[_{XP} YP [_X X ZP]]} dyadic structure (X = *become*)

On the other hand, flavors like *do* and *make* are typically expressed by what Hale & Keyser (2002) dub monadic structure (that of unergative verbs), like (ii):

(ii) _[_{XP} X ZP] monadic structure (X = *do*)

Although these possibilities might shed light on the issues I have just considered, some problems rapidly come to mind. In particular, dyadic structures are not exclusively headed by *become*: if the head is prepositional (and not verbal) in nature, the semantics of X can express not only *terminal coincidence* (e.g., TO, FROM, etc.) –actually, *become* is plausibly a sub-type of the *terminal coincidence* flavor–, but also *central coincidence* (e.g., IN, WITH, etc.).

8. Conclusions

In this chapter I have considered the role of the Case/agreement systems with respect to islandhood. This was done in order to assess Chomsky's (to appear) claim that the specifiers of phase heads give rise to CED effects.

Following the discussion in chapter 2, I have argued that there is nothing particularly special about phasal specifiers (the *edges*). Consequently, I have provided evidence that Huang's (1982) *Subject Condition* is related to SPEC-T_S, a position which creates a freezing effect (see Boeckx 2003a).

I have put forward an analysis of islandhood that builds on Gallego & Uriagereka's (2007; to appear) *Activity Condition* based account. Contrary to our implementation in those papers, I have phrased my proposal by emphasizing the role of Case (i.e., Pesetsky & Torrego's T). In particular, I have claimed that *for an XP to be transparent it must be able to establish an Agree dependency. Crucially, for XPs to be able to do so, they must bear unvalued T* –being 'active,' in Chomsky's terms. The idea is summarized in my C/ACoE, which I have applied in the case of subjects, objects, and adjuncts.

(207) CASE/AGREEMENT CONDITION ON (SUB-)EXTRACTION (C/ACoE final version)

- a. A syntactic object whose φ -features can be matched is transparent
- b. φ -features of a syntactic object can be matched if it bears *unvalued T*

I have also examined cases where sub-extraction takes place from already displaced constituents (the famous examples raised by Esther Torrego in the mid 80s), arguing that the impossibility to sub-extract is the result of a 'freezing effect' terminating chains (see Boeckx 2006a, Bošković 2005, Chomsky 2001, and Rizzi 2006). With Gallego & Uriagereka (to appear), I take this conclusion to be more comprehensive than any of the alternatives the recent literature has provided, which does not mean that it is compelling: to me, it is not clear at all why an effect taking place after Transfer (like the types of semantic freezing Rizzi considers) should block computational sub-extraction.

In any event, configuration wise, both the lower VP-shell of a deadjectival verb such as *clear* or *break* and a PP receive the analysis in (i), so it is hard to see how flavors can be read off from configurations alone. Further investigation is needed in this area.

CHAPTER V

SUMMARY

This dissertation has discussed the notion of *phase* and its relevance for linguistic theory and parametric variation.

Following Chomsky (2000; 2001; 2004; 2005; 2007; to appear), the previous chapters have argued in favor of the idea that syntactic computation operates through derivational units, the so-called *phases* (alternatively, *cycles*, *phrases*, *barriers*, *spell-out units*, etc.): given domains where operations take place in accord with principles of optimization (e.g., last resort, inclusiveness, no tampering, minimal search, etc.) and interaction with external systems. After considering different evidence in support of such domains, I have concluded that the strongest evidence for having phases is related to the (striking) existence of uninterpretable morphology within the Case/agreement systems. I have expressed this idea through the *Phase Condition*:

(1) PHASE CONDITION

Uninterpretable morphology is phase bounded

In the context of Chomsky's *Phase Theory* I have also investigated issues that belong to parametric variation (see chapter 3, and sections 4 and 5 of chapter 2), paying special attention to *Null Subject Languages* (and, more particularly, to the variety of Spanish spoken in Spain). Simplifying, three main claims have been made: first, there is a correlation between C* and *v** (the phase heads) in terms of morphological richness that boosts their *Left Periphery* (the richer the morphology of C*/*v**, the more left-peripheral fronting they can display); second, subjunctive dependents qualify as a Romance counterpart of English-type ECMs (instantiating what Chomsky dubs "T_{def}"); third, some varieties of verb movement (like that of NSLs) manifest "domain extension" effects that strongly indicate a syntactic status, triggering the application of a morphologically motivated Transfer, referred to as *Phase Sliding*.

(2) PHASE SLIDING

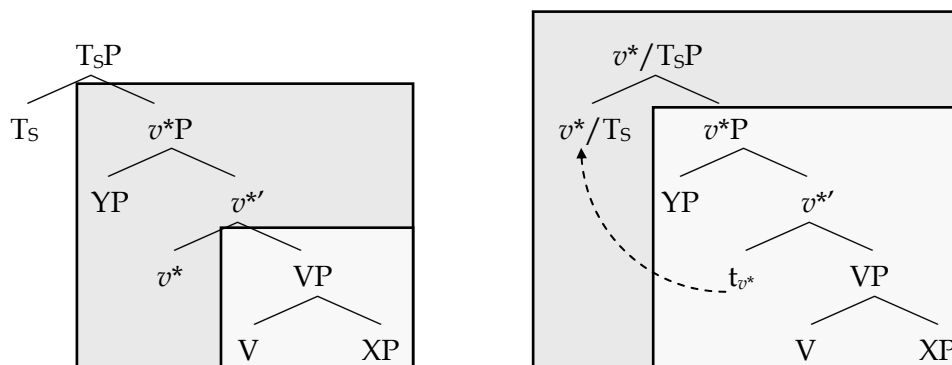

COMPLEMENT DOMAIN

EDGE DOMAIN

Still within this very topic (syntactic verb movement), section 5 of chapter 3 is devoted to the study of VOS and VSO sequences, and its consequences for *Phase Theory*. Building on Ordóñez (1998b; 2005), I have argued that VOS (in Spanish, European Portuguese, and Galician) is generated by internal Merge of the object above the *in situ* subject (i.e., *Object Shift*), hence posing a minimality problem for nominative Case assignment –solved if a restricted version of *equidistance* (see Chomsky 1993a) is appealed to.

In the light of some interesting correlations, I make the crucial claim that those NSLs that made use of *Object Shift* to generate VOS are the ones that can generate VSO, formalizing it as follows:

(3) VOS – VSO GENERALIZATION

If L generates VOS through *Object Shift*, then it licenses VSO

Finally, chapter 4 has focused on islandhood: the ban on trying to sub-extract phrases from certain syntactic domains. There I discuss different recent proposals to capture the Huang’s (1982) CED effects, including Chomsky’s (to appear) recent

attempt to reduce the *Subject Condition* to a locality problem that phasal specifiers (the *edges*) pose. In line with Boeckx (2003a), I have advocated for a view in which the insular status of syntactic domains cannot be completely accounted for in structural terms, being parasitic on the interaction of Case and agreement instead. In particular, I have proposed (4):

(4) CASE/AGREEMENT CONDITION ON (SUB-)EXTRACTION

- a. A syntactic object whose φ -features can be matched is transparent
- b. φ -features of a syntactic object can be matched if it bears *unvalued T*

What (4) tries to spell-out is the idea that syntactic objects are transparent (non-islands) if they can establish *Agree* with the relevant functional heads –Chomsky’s *Probes*. Importantly, for them to be able to undergo *Agree*, syntactic objects must be *active*, that is, they must bear unvalued Case. In this respect, and largely adopting ideas of Pesetsky & Torrego’s (2001), I have understood Case as an aspect/tense feature D heads are endowed with.

Following the narrative line of the preceding chapters, I therefore relate islandhood not to configurational issues, but to morphology, a conclusion that is reinforced on both conceptual and empirical grounds: conceptually, as language after language it is agreement (not phrase structure) that varies, and empirically, as it is a well-known fact that conditions on sub-extraction appear to be governed by morphological mechanisms (e.g., partial vs. full agreement, clitics, resumption, expletives, etc.).

REFERENCES

- Abels, Klaus (2003): *Successive Cyclicity, Anti-Locality, and Adposition Stranding*, PhD dissertation, UConn.
- Aboh, Enoch (1998): *From the syntax of Gungbe to the grammar of Gbe*, PhD dissertation, University of Geneva.
- Aboh, Enoch (2004): *The morphosyntax of complement-head sequences*, Oxford (New York): Oxford University Press.
- Alexiadou, Artemis & Elena Anagnostopoulou (1998): "Parametrizing Agr: Word Order, V-Movement and EPP-Checking," *Natural Language and Linguistic Theory* 16: 491-539.
- Alexiadou, Artemis & Elena Anagnostopoulou (2001): "The subject *in situ* generalization, and the role of Case in driving computations," *Linguistic Inquiry* 32: 193-231.
- Alexiadou, Artemis & Elena Anagnostopoulou (2007): "The subject-*in-situ* generalization revisited," in H. Gärtner & U. Sauerland (eds), *Proceedings of the Workshop on Interfaces + Recursion = Language?* Mouton de Gruyter, 31-59.
- Anagnostopoulou, Elena (2003): "Strong and Weak Person Restrictions. A feature checking analysis," in L. Heggie & F. Ordóñez (eds.), *Clitic and affix combinations: Theoretical perspectives*, Amsterdam: John Benjamins, 199-235.
- Anagnostopoulou, Elena & Martin Everaert (1999): "Toward a More Complete Typology of Anaphoric Expressions," *Linguistic Inquiry* 30: 97-119.
- Arad, Maya (1998): "Psych-Notes," *UCL WPL* 10: 1-22.
- Arad, Maya (2002): "Universal features and language-particular morphemes," in A. Alexiadou (ed.), *Theoretical Approaches to Universals*, Amsterdam: John Benjamins, 15-40.
- Arnáiz, Alfredo (1992): "On Word Order in Wh-questions in Spanish," in A. Kathol & J. Beckman (eds.), *MIT Working Papers in Linguistics*, 16, 1-10.
- Ausín, Adolfo (2001): *On A-Movement*, PhD dissertation, UConn.
- Baker, Mark C. (1988): *Incorporation: A Theory of Grammatical Function Changing*, Chicago: University of Chicago Press.
- Baker, Mark C. (1995): *The polysynthesis parameter*, New York: Oxford University Press
- Baker, Mark C. (2001): *The Atoms of Language*, Basic Books: New York.
- Baker, Mark C. (2003): *Lexical Categories. Verbs, Nouns, and Adjectives*, Cambridge, Cambridge University Press.
- Barbosa, M. Pilar (1995): *Null Subjects*, PhD dissertation, MIT.
- Barbosa, Pilar (1997): "Subject Positions in the Null Subject Languages," *Seminários de Linguística* 1: 39-63.
- Barbosa, Pilar (2001): "On Inversion in Wh-questions in Romance," in A. Hulk & J. I. Pollock (eds.), *Subject Inversion in Romance and the Theory of Universal Grammar*, Oxford: Oxford University Press, 20-59.
- Belletti, Adriana (2001): "'Inversion' as Focalization," in A. Hulk & J. I. Pollock (eds.), *Subject Inversion in Romance and the Theory of Universal Grammar*, Oxford: Oxford University Press, 60-90.
- Belletti, Adriana (2004): "Aspects of the Low IP Area," in L. Rizzi (ed.), *The Structure of CP and IP. The Cartography of Syntactic Structures (vol. 2)*, Oxford (New York): Oxford University Press, 16-51.
- Belletti, Adriana (2005): "Extended doubling and the VP periphery," *Probus* 17: 1-35.
- Belletti, Adriana & Luigi Rizzi (1981): "The Syntax of *ne*: Some Theoretical Implications," *The Linguistic Review* 1: 117-154.
- Belletti, Adriana & Luigi Rizzi (1988): "Psych-Verbs and θ -Theory," *Natural Language and Linguistic Theory* 6: 291-352.
- Bello, Andrés (1847): *Gramática de la lengua castellana, destinada al uso de los americanos, edición con notas de Rufino José Cuervo* (2 vols.), Ramón Trujillo (ed.), Madrid: Arco/Libros.
- Benincà, Paola & Cecilia Poletto (2004): "A case of *do*-support in Romance," *Natural Language and Linguistic Theory* 22: 51-94.

- Bhatt, Rajesh (1999): *Covert Modality in Non-Finite Contexts*, PhD dissertation, University of Pennsylvania.
- Bobaljik, Jonathan (1999): "Adverbs: The Hierarchy Paradox," *Glott International* 4: 27-28.
- Bobaljik, Jonathan David & Diane Jonas (1996): "Subject Positions and the Roles of TP," *Linguistic Inquiry* 27: 195-236.
- Boeckx, Cedric (1999a): "Conflicting c-command requirements," *Studia Linguistica* 53: 227-250.
- Boeckx, Cedric (1999b): "Decomposing French Questions," *University of Pennsylvania WPL* 6: 69-80.
- Boeckx, Cedric (2000a): "Quirky Agreement," *Studia Linguistica* 53: 354-380.
- Boeckx, Cedric (2000b): "Properties of French Interrogatives," Ms., UConn.
- Boeckx, Cedric (2001): "Scope Reconstruction and A-Movement," *Natural Language and Linguistic Theory* 19: 503-519.
- Boeckx, Cedric (2002a): "Elemental Relations in Syntax," Ms., UMD.
- Boeckx, Cedric (2002b): "French complex inversion in the light of a minimalist program," in J. Camps & C. Wiltshire (eds.), *Proceedings of Linguistic Symposium on Romance Linguistics (LSRL) 30*, Amsterdam: John Benjamins, 43-56.
- Boeckx, Cedric (2003a): *Islands and Chains. Stranding as Resumption*, Amsterdam: John Benjamins.
- Boeckx, Cedric (2003b): "Case Matters and Minimalist Concerns," *Harvard WPL* 8: 159-187.
- Boeckx, Cedric (2003c): "Symmetries and Asymmetries in Multiple Checking," in C. Boeckx & K. Grohmann (eds.), *Multiple Wh-Fronting*, Amsterdam: John Benjamins, 15-24.
- Boeckx, Cedric (2003d): "French Wh-in-situ Interrogatives as (Co)vert Clefts," Ms., Harvard University.
- Boeckx, Cedric (2003e): "Review to *The Syntax of Adjuncts*," *Studies in the Linguistic Sciences* 32: 95-101.
- Boeckx, Cedric (2003f): "Free Word Order in Minimalist Syntax," *Folia Linguistica* 37: 77-102.
- Boeckx, Cedric (2004): "Long distance agreement in Hindi: some theoretical implications," *Studia Linguistica* 58: 1-14.
- Boeckx, Cedric (2006a): "Bare Syntax," Ms., Harvard University.
- Boeckx, Cedric (2006b): "Case and Agreement: The Syntax of A-Dependencies," Ms., Harvard University.
- Boeckx, Cedric (2006c): *Agreement Systems*, Amsterdam: John Benjamins.
- Boeckx, Cedric (2006d): *Minimalist Essays*, Amsterdam: John Benjamins.
- Boeckx, Cedric (2007): *Understanding Minimalist Syntax: Lessons from Locality in Long-distance Dependencies*, Oxford: Blackwell.
- Boeckx, Cedric & Kleanthes Grohmann (2003): *Multiple Wh-Fronting*, Amsterdam: John Benjamins.
- Boeckx, Cedric & Kleanthes Grohmann (2007): "Remark: Putting Phases in Perspective," *Syntax* 10: 204-222.
- Boeckx, Cedric, Norbert Hornstein, and Jairo Nunes (2007): "Overt Copies in Reflexive and Control Structures: A Movement Analysis," *UMD WPL* 15: 1-46.
- Boeckx, Cedric & Howard Lasnik (2006): "Intervention and Repair," *Linguistic Inquiry* 38: 150-155.
- Boeckx, Cedric & Fumikazu Niinuma (2004): "Conditions on Agreement in Japanese," *Natural Language and Linguistic Theory* 22: 453-480.
- Boeckx, Cedric & Sandra Stjepanović (2001): "Head-ing toward PF," *Linguistic Inquiry* 32: 345-355.
- Boeckx, Cedric & Juan Uriagereka (2007): "Minimalism," in G. Ramchand & C. Reiss (eds.), *Handbook of Linguistic Interfaces*, Oxford: Oxford University Press. [cited by manuscript version]
- Bonet, Eulàlia (1989): "Subjects in Catalan," in L. Cheng & H. Demirdache (eds.), *MIT WPL* 13: 1-26.

- Bonet, Eulàlia (1994): "The Person-Case Constraint: A Morphological Approach," in H. Harley & C. Phillips (eds.), *The Morphology-Syntax Connection*, Cambridge (Mass.): MIT Press, 33-52.
- Borer, Hagit (1984): *Parametric Syntax: Case Studies in Semitic and Romance Languages*, Dordrecht: Foris.
- Borer, Hagit (2005a): *Structuring Sense. Vol. I: In name Only*, Oxford: Oxford University Press.
- Borer, H. (2005b): *Structuring Sense. Vol. II: The Normal Course of Events*, Oxford: Oxford University Press
- Bošković, Željko (1999): "On multiple feature-checking: Multiple wh-fronting and multiple head movement," in S. Epstein & N. Hornstein (eds.), *Working Minimalism*, Cambridge (Mass.): MIT Press, 159-187.
- Bošković, Željko (2002): "A-Movement and the EPP," *Syntax* 5: 167-218.
- Bošković, Željko (2005): "On the Operator Freezing Effect," Ms., UConn.
- Bosque, Ignacio (1980): "Retrospective imperatives," *Linguistic Inquiry* 11: 415-419.
- Bosque, Ignacio (1983): "Sobre la interrogación indirecta," *Dicenda* 1: 13-34.
- Bosque, Ignacio (1984a): "Sobre la sintaxis de las oraciones exclamativas," *Hispanic Linguistics* 1: 283-304.
- Bosque, Ignacio (1984b): "La selección de las palabras interrogativas," *Verba* 11: 245-273.
- Bosque, Ignacio (1994): "La negación y el principio de las categorías vacías," in V. Demonte (ed.), *Gramática del español*, México: El Colegio de México, 167-199.
- Bosque, Ignacio (1995): "Degree Quantification and Modal Operators in Spanish," Ms., Universidad Complutense de Madrid.
- Bosque, Ignacio (1996): *El sustantivo sin determinación. La ausencia de determinación en la lengua española*, Madrid: Visor.
- Bosque, Ignacio (1997): "Preposición tras preposición," in M. Almeida & J. Dorta (eds.) *Contribuciones al estudio de la lingüística hispánica. Homenaje al profesor Ramón Trujillo*, (vol. 1), Tenerife: Montesinos, 133-156.
- Bosque, Ignacio (1999): "Sobre la estructura sintáctica de una construcción focalizadora," Ms., Universidad Complutense de Madrid.
- Bosque, Ignacio (2001): "Adjective position and the interpretation of indefinites," in J. Gutiérrez-Rexach and L. Silva-Villar (eds.), *Current Issues in Spanish Syntax and Semantics*, Berlin: Mouton de Gruyter, 17-63.
- Bosque, Ignacio (2002): "¿Singular + Singular = Plural? Aspectos de la concordancia de número en las construcciones coordinadas," Ms., Universidad Complutense de Madrid.
- Broeckhuis, Hans (2005): "Extraction from subjects: some remarks on Chomsky's 'On Phases'," in H. Broeckhuis et al. (eds.), *Organizing Grammar. Studies in Honor of Henk van Riemsdijk*, Berlin: Mouton de Gruyter, 59-68.
- Broeckhuis, Hans (2007): "On the Proper Definition of Closeness. Does Defective Intervention Exist?," Ms., University of Tilburg.
- Browning, Margaret (1987): *Null operator constructions*, PhD dissertation, MIT.
- Brucart, José M. (1992): "Some Asymmetries in the Functioning of Relative Pronouns in Spanish," *Catalan WPL* 1: 113-143.
- Brucart, José M. (1993): "Sobre la estructura de SComp en español," in A. Viana (ed.), *Sintaxi. Teoria i perspectives*, Lleida: Pagès, 59-102.
- Brucart, José M. (1994a): "Sintaxis y semántica en el análisis generativo de la oración," in F. Hernández Paricio (ed.), *Perspectivas sobre la oración*, Zaragoza: Publicaciones de la Universidad de Zaragoza: 9-69.
- Brucart, José M. (1994b): "Syntactic Variation and Gramatical Primitives in Generative Grammar," in A. Briz & Manuel Pérez Saldanya (eds.), *Categories and Functions, LynX, A Monographic Series in Linguistics and World Perception*, 145-176.
- Brucart, José M. (1997): "Concordancia *ad sensum* y partitividad en español," in M. Almeida & J. Dorta (eds.) *Contribuciones al estudio de la lingüística hispánica. Homenaje al profesor Ramón Trujillo*, (vol. 1), Tenerife: Montesinos, 157-183.

- Brucart, José M. (1999): "La estructura del sintagma nominal: las oraciones de relativo," in I. Bosque & V. Demonte (eds.), *Gramática descriptiva de la lengua española*, Madrid: Espasa Calpe, 395-522.
- Burzio, Luigi (1986): *Italian Syntax: A Government-Binding Approach*, Dordrecht: Reidel.
- Burzio, Luigi (1991): "The morphological basis of anaphora," *Linguistics* 27: 81-105.
- Butler, Jonny (2006): "Quantifying Edges," paper presented at *Edges in Syntax*, Cyprus College (Nicosia, Cyprus) in May of 2006.
- Camacho, José (2003): *The Structure of Coordination: Conjunction and Agreement Phenomena in Spanish and Other Languages*, Dordrecht: Kluwer.
- Camacho, José (2005): "Do Subjects have a place in Spanish?," Ms., Rutgers University.
- Campos, Héctor (1997): "On Subject Extraction and the Antiagreement Effect in Romance," *Linguistic Inquiry* 28: 92-119.
- Cardinaletti, Anna (1997): "Subjects and clause structure," in L. Haegeman (ed.) *The New Comparative Syntax*, London: Longman, 33-63.
- Cardinaletti, Anna (1999): "Italian emphatic pronouns are postverbal subjects," *University of Venice WPL* 1-2: 59-92.
- Cardinaletti, Anna (2001a): "Subjects and *Wh*-questions: A Reply to Uriagereka," Ms. University of Bologna/University of Venice.
- Cardinaletti, Anna (2001b): "A second thought on *emarginazione*: Destressing vs 'Right Dislocation'," in G. Cinque & G.P. Salvi (eds.), *Current Studies in Italian Syntax. Essays offered to Lorenzo Renzi*, Amsterdam: North Holland, 117-135.
- Cardinaletti, Anna (2004): "Towards a cartography of subject positions," *The structure of CP and IP. The Cartography of Syntactic Structures (vol. 2)*, L. Rizzi ed., 115-165, Oxford (New York): Oxford University Press.
- Cardinaletti, Anna (2006): "Subjects and *Wh*-Questions. Some New Generalizations," Ms., Università Ca' Foscari di Venezia.
- Cardinaletti, Anna & Ur Shlonsky (2004): "Clitic positions and restructuring in Italian," *Linguistic Inquiry* 35: 519-557.
- Carnie, Andrew, Heidi Harley, & Elizabeth Pyatt (2000): "VSO Order as Raising Out of IP," in A. Carnie & E. Guilfoyle (eds.), *The Syntax of Verb Initial Languages*, Oxford: Oxford University Press, 39-59
- Carstens, Vicki (2003): "Rethinking Complementizer Agreement: Agree with a Case Checked Goal," *Linguistic Inquiry* 34: 393-412.
- Castillo, Juan Carlos, John Drury & Kleantes Grohmann (2000): "No more EPP," in R. Billerey & B. D. Lillehaugen (eds.), *Proceedings of the 19th West Coast Conference on Formal Linguistics*, Somerville (Mass.): Cascadilla Press, 153-166.
- Cecchetto, Carlo (2000): "Doubling structures and reconstruction," *Probus* 12: 93-126.
- Cecchetto, Carlo (2006): "Condition (C) as a Case of Mislabeleding," Ms., Università Milano-Bicocca.
- Chametzky, Robert (2000): *Phrase structure. From GB to minimalism*, Oxford: Blackwell
- Cheng, Lisa (1991): *On the typology of wh-questions*, PhD dissertation, MIT.
- Chomsky, Noam (1955): *The Logical Structure of Linguistic Theory*, Mimeograph, Harvard University. [published in 1975, New York: Plenum]
- Chomsky, Noam (1957) *Syntactic Structures*, The Hague: Mouton
- Chomsky, Noam (1964): *Current Issues in Linguistic Theory*, The Hague: Mouton.
- Chomsky, Noam (1965): *Aspects of the Theory of Syntax*, Cambridge (Mass.): MIT Press.
- Chomsky, Noam (1973): "Conditions on Transformations," in S. Anderson & P. Kiparsky (eds.), *A festschrift for Morris Halle*, New York: Holt, Rinehart and Winston, 232-286. [reprinted in Chomsky 1977b]
- Chomsky, Noam (1975): *Reflections on Language*, New York: Pantheon Books.
- Chomsky, Noam (1977a): "On *wh*-Movement," in P. Culicover et al. (eds.), *Formal Syntax*, New York: Academic Press, 71-132.
- Chomsky, Noam (1977b): *Essays of form and interpretation*, New York: Elsevier North-Holland.
- Chomsky, Noam (1981): *Lectures on Government and Binding*, Dordrecht: Foris Publications.
- Chomsky, Noam (1982): *Some Concepts and Consequences of the Theory of Government and Binding*, Cambridge (Mass.): MIT Press.

- Chomsky, Noam (1986a): *Barriers*, Cambridge (Mass.): MIT Press.
- Chomsky, Noam (1986b): *Knowledge of Language. Its Nature, Origin, and Use*, New York: Praeger.
- Chomsky, Noam (1991): "Some notes on economy of derivation and representation," in R. Friedin (ed.), *Principles and Parameters in Comparative Grammar*, Cambridge (Mass.): MIT Press. [reprinted in Chomsky 1995a]
- Chomsky, Noam (1993a): "A Minimalist Program for Linguistic Theory," in K. Hale & S. J. Keyser (eds.) *The View from Building 20: Essays in Linguistics in Honor of Sylvain Bromberger*, Cambridge (Mass.): MIT Press, 1-52. [reprinted in Chomsky 1995a]
- Chomsky, Noam (1993b): *Language and Thought*, Wakefield (RI): Moyer Bell.
- Chomsky, Noam (1995a): *The Minimalist Program*, Cambridge (Mass.): MIT Press.
- Chomsky, Noam (1995b): "Categories and Transformations," in N. Chomsky, *The Minimalist Program*, Cambridge (Mass.): MIT Press, 219-394.
- Chomsky, Noam, (1995c): "Bare Phrase Structure," in G. Webelhuth (ed.), *Government and Binding theory and the Minimalist Program*, London: Blackwell, 383-439.
- Chomsky, Noam (2000): "Minimalist Inquiries: The Framework," in R. Martin, D. Michaels, & J. Uriagereka, *Step by Step. Essays on Minimalist Syntax in Honour of Howard Lasnik*, Cambridge (Mass.): MIT Press, 89-155.
- Chomsky, Noam (2001): "Derivation by Phase," in M. Kenstowicz (ed.), *Ken Hale: A Life in Language*, Cambridge (Mass.): MIT Press, 1-52.
- Chomsky, Noam (2004): "Beyond Explanatory Adequacy," in A. Belletti (ed.), *Structures and Beyond. The Cartography of Syntactic Structures (vol. 3)*, Oxford (New York): Oxford University Press, 104-131.
- Chomsky, Noam (2005): "Three factors in language design," *Linguistic Inquiry* 36: 1-22.
- Chomsky, Noam (2007): "Approaching UG from below," in U. Sauerland & H-M. Gärtner (eds.), *Interfaces + Recursion = Language? Chomsky's minimalism and the view from syntax-semantics*, Berlin: Mouton de Gruyter, 1-30.
- Chomsky, Noam (to appear): "On Phases," in C. Otero et al. (eds.), *Foundational Issues in Linguistic Theory*, Cambridge (Mass.): MIT Press. [cited by manuscript version]
- Chomsky, Noam & Howard Lasnik (1977): "Filters and Control," *Linguistic Inquiry* 8: 425-504.
- Chomsky, Noam & Howard Lasnik (1995): "The Theory of Principles and Parameters," in N. Chomsky (1995a), 13-127
- Cinque, Guglielmo (1980): "Extraction from NP in Italian," *Journal of Italian Linguistics* 5: 47-99.
- Cinque, Guglielmo (1990): *Types of A'-Dependencies*, Cambridge (Mass.): MIT Press.
- Cinque, Guglielmo (1993): "A Null Theory of Phrase and Compound Stress," *Linguistic Inquiry* 24: 239-298.
- Cinque, Guglielmo (1996): "Long Wh-movements and Referentiality," in R. Freidin (ed.), *Current Issues in Comparative Grammar*. Dordrecht: Kluwer, 226-247.
- Cinque, Guglielmo (1999): *Adverbs and Functional Heads. A Cross-Linguistic Perspective*, Oxford (New York): Oxford University Press.
- Cinque, Guglielmo (2004): "Issues in Adverbial Syntax," *Lingua* 114: 683-710.
- Cinque, Guglielmo (2006): "Complement and Adverbial PPs: Consequences for Clause Structure," Ms., Università di Venezia.
- Citko, Barbara (2006): "Missing Labels," Ms., University of Washington.
- Collins, Chris (1991): "Why and How Come," in L. Cheng & H. Demirdache (eds.), *More Papers on Wh-Movement*, MIT WPL 15: 31-45.
- Collins, Chris (2002): "Eliminating labels," in S. Epstein & T. Seely (eds.), *Derivation and explanation in the minimalist program*, Malden (Mass.): Blackwell, 106-132.
- Contreras, Heles (1976): "Theme and Rheme in Spanish Syntax," in M. Luján & F. Hensey (eds.), *Current studies in Romance linguistics*, Washington: Georgetown University Press, 330-342.
- Contreras, Heles (1984): "Multiple Questions in English and Spanish," in P. Baldi (ed.), *Papers from the XIIth Linguistic Symposium on Romance Languages*, Amsterdam: John Benjamins, 121-133.

- Contreras, Heles (1990): "Closed Domains," *Probus* 1: 163-180.
- Contreras, Heles & Pascual J. Masullo (2000): "Conditions on Motivated Merge," paper presented at the 10th Colloquium on Generative Grammar, Alcalá de Henares (Madrid), Spain.
- Costa, João (2000): "Word order and discourse-configurationality in European Portuguese," in J. Costa (ed.), *Portuguese syntax: New comparative studies*, Oxford (New York): Oxford University Press, 94-115.
- Costa, João (2002): "VOS in Portuguese: Arguments against an analysis in terms of remnant movement," in A. Alexiadou et al. (eds.), *Dimensions of Movement*, Amsterdam: John Benjamins, 69-89.
- Culicover, Peter (1970): *Syntactic and semantic investigation*, PhD dissertation, MIT.
- Culicover, Peter & Michael Rochemont (1992): "Adjunct extraction from NP and the ECP," *Linguistic Inquiry* 23: 496-501.
- Davidson, Donald (1967): "The logical form of action sentences," in D. Davidson *Essays on actions and events*, Oxford (New York): Clarendon Press, 105-122.
- Demirdache, Hamida & Myriam Uribe-Etxebarria (2000): "The Primitives of Temporal Relations," in R. Martin, David Michaels, & J. Uriagereka (eds.), *Step by Step. Essays on Minimalist Syntax in Honour of Howard Lasnik*, Cambridge (Mass.): MIT Press, 157-186.
- Demonte, Violeta (1991): *Detrás de la palabra. Estudios de gramática del español*, Madrid: Alianza.
- Demonte, Violeta & Olga Fernández-Soriano (2002): "Features in Comp and syntactic variation: the case of '(de)queísmo' in Spanish," Ms., Universidad Autónoma de Madrid.
- Demonte, Violeta & Olga Fernández-Soriano (2005): "Features in Comp and syntactic variation: the case of '(de)queísmo' in Spanish," *Lingua* 115: 1063-1082.
- Den Besten, Hans (1983): "On the interaction of root transformations and lexical deletive rules," in W. Abraham (ed.), *On the Formal Syntax of Westgermania*, Amsterdam: John Benjamins.
- Den Dikken, Marcel (2006): *Relators and Linkers. The Syntax of Predication, Predicate Inversion, and Copulas*, Cambridge (Mass.): MIT Press.
- Den Dikken, Marcel (2007): "Phase Extension. Contours of a theory of the role of head movement in phrasal extraction," *Theoretical Linguistics* 33: 1-41.
- Depiante, Marcela (2001a): "On Null Complement Anaphora in Spanish and Italian," *Probus* 13: 193-221.
- Depiante, Marcela (2001b): "Ellipsis in Spanish and the Stranded Affix Filter," *Proceedings of NELS*, 31.
- Donati, Caterina (1995): "Il que relativo spagnolo," *Lingua e Stile* 3: 565-595.
- Donati, Caterina (1997): "Comparative Clauses as Free Relatives: a Raising Analysis," *Probus*, 9, 145-166.
- Donati, Caterina (2000): *La sintassi della comparazione*, Padova: Unipress.
- Donati, Caterina (2006a): "On wh-head movement," in L. Cheng & N. Corver (eds.), *Wh-movement: moving on*, Cambridge: MIT Press, 21-46.
- Donati, Caterina (2006b): "Labels and Merge," paper presented at *Edges in Syntax*, Cyprus College, Nicosia (Cyprus).
- Drury, John (2005): *Alternative Directions for Minimalist Inquiry: Expanding and Contracting Phases of Derivations*, PhD dissertation, UMD.
- Embick, David & Sabine Iatridou (1994): "Conditional Inversion," *Proceedings of NELS* 24, 189-203.
- Emonds, Joseph (1970): *Root and structure preserving transformations*, PhD dissertation, MIT.
- Emonds, Joseph (1985): *A Unified Theory of Syntactic Categories*, Dordrecht: Foris.
- Epstein, Samuel D. et al. (1998): *A derivational approach to syntactic relations*, Oxford: Oxford University Press.
- Epstein, Samuel David & T. Daniel Seely (2002): "Rule Applications as Cycles in a Level-free Syntax," in S. Epstein & T. Seely (eds.), *Derivation and Explanation in the Minimalist Program*, Malden (Mass.): Blackwell, 65-89.
- Etxepare, Ricardo (1997): *The Syntax of Illocutionary Force*, PhD dissertation, UMD.

- Etxepare, Ricardo (1998): "On the Structure of Declarative Clauses," in A. Schwegler, B. Tranel & M. Uribe-Etxebarria (eds.), *Romance Linguistics. Theoretical Perspectives*, Amsterdam/Philadelphia: John Benjamins, 53-66.
- Etxepare, Ricardo (1999): "On Null Complementizers in Spanish," *International Journal of Basque Linguistics and Philology* XXX-2, 469-496.
- Etxepare, Ricardo (2002): "On Quotative Constructions in (Peninsular) Spanish," Ms. CNRS/EHU.
- Etxepare, Ricardo (2005): "Number Long Distance Agreement in (Substandard) Basque," Ms., CNRS-IKER.
- Etxepare, Ricardo & Kleanthes Grohmann (2005): "Aspectual Variation in Adult Root Infinitivals Constructions," paper presented in the *15th Colloquium on Generative Grammar*, Universitat de Barcelona, Barcelona, 4-6 April 2005.
- Etxepare, Ricardo & Myriam Uribe-Etxebarria (2005): "In-situ wh-phrases in Spanish: locality and quantification," *Recherches linguistiques de Vincennes* 33. *L'architecture propositionnelle, la syntaxe de la périphérie gauche*.
- Fernández Leborans, María Jesús (1999): "La predicación: las oraciones copulativas," in I. Bosque & V. Demonte (eds.), *Gramática descriptiva de la lengua Española*, Madrid: Espasa, 2357-2460.
- Fernández-Soriano, Olga (1999): "Two types of impersonal sentences in Spanish: Locative and dative subjects," *Syntax*, 2:2, 101-140.
- Fiengo, Robert (1978): "On Trace Theory," *Linguistic Theory* 8: 35-81.
- Fortuny, Jordi (2007): *The Emergence of Order in Syntax*, PhD dissertation, UB.
- Fox, Danny (1995): "Economy and Scope," *Natural Language Semantics* 23: 283-341.
- Fox, Danny (2000): *Economy and Semantic Interpretation*, Cambridge (Mass.): MIT Press.
- Fox, Danny & David Pesetsky (2005): "Cyclic Linearization of Syntactic Structure," *Theoretical Linguistics* 31: 1-45.
- Frampton, John et al. (1999): "Remarks on "Derivation by Phase": Feature Valuation, Agreement, and Intervention," Ms., Northeastern University.
- Frampton, John & Sam Gutmann (2000): "Agreement is Feature Sharing," Ms., Northeastern University.
- Franco, Jon (1990): "Towards a Typology of Psych Verbs: Evidence from Spanish," *MIT WPL* 12: 46-62.
- Fujii, Tomohiro & Hajime Ono (2006): "English Exclamatives and T-to-C Movement," *UMD WPL* 14: 163-187.
- Fukui, Naoki & Peggy Speas (1986): "A theory of category projection and its applications," in N. Fukui et al. (eds.), *MIT WPL* 8: 128-172.
- Gallego, Ángel J. (2003): "La interacción sintáctica entre T y C en español," Ms., UAB / IUOG.
- Gallego, Ángel J. (2004a): "T-to-C and Σ -to-C Movement in (Peninsular) Spanish and Catalan," paper presented in the *XIV Colloquium on Generative Grammar*, Universidade do Porto, Porto (Portugal).
- Gallego, Ángel J. (2004b): "Phase Effects in Iberian Romance," Ms., UAB / Euskal Herriko Unibertsitatea.
- Gallego, Ángel J. (2004c): *Hypotactic and Paratactic Dependencies*, Master Thesis, UAB.
- Gallego, Ángel J. (2005): "Phase Sliding," Ms., UAB / UMD.
- Gallego, Ángel J. (2006a): "Phase Effects in (Iberian) Romance," *Cuadernos de Lingüística del IUOG* 13: 59-78.
- Gallego, Ángel J. (2006b): "T-to-C Movement in Relative Clauses," in J. Doetjes & P. González (eds.), *Romance Languages and Linguistic Theory 2004. Selected papers from "Going Romance" 2004*, Amsterdam: John Benjamins, 143-170.
- Gallego, Ángel J. (2007a): "Connectivity in Markovian Dependencies," in S. Blaho et al. (eds.), *Proceedings of XIV ConSOLE*: 73-98.
- Gallego, Ángel J. (2007b): "Instability," *Cuadernos de Lingüística del IUOG* 14: 87-99
- Gallego, Ángel J. & Juan Uriagereka (2007): "Conditions on Sub-extraction," in L. Eguren & O. Fernández-Soriano (eds.), *Selected Papers from XVI Colloquium on Generative Grammar*, Amsterdam: John Benjamins, 45-70.

- Gallego, A. & Uriagereka, J. (in press): "Sub-extraction from Subjects: A Phase Theory Account," *Romance Linguistics 2006*, J. Camacho et al. (eds), Amsterdam: John Benjamins, 149-162
- Gallego, Ángel J. & Juan Uriagereka (to appear): "Sub-extraction from Phase Edges," in *The Complementiser Phase: subjects and wh-dependencies*, P. Panagiotidis (ed.), Oxford: OUP.
- Gengel, Kirsten (2007): "Contrastivity and Deletion: A Feature-Based Account of Ellipsis," in L. Eguren & O. Fernández-Soriano (eds.), *Selected Papers from XVI Colloquium on Generative Grammar*, Amsterdam: John Benjamins, 71-88.
- George, Leland & Jaklin Kornfilt (1981): "Finiteness and boundedness in Turkish," in F. Heny (ed.), *Binding and filtering*, Cambridge (Mass.): MIT Press, 105-127.
- Giorgi, Alessandra & Fabio Pianesi (2004): "Complementizer Deletion in Italian," in L. Rizzi (ed.), *The Structure of CP and IP. The Cartography of Syntactic Structures (vol. 2)*, Oxford (New York): Oxford University Press, 190-210.
- González, Raquel (2008): *La polaridad positiva en español*, Universidad Complutense de Madrid / Instituto Universitario de Investigación Ortega y Gasset.
- Goodall, Grant (1993): "Spec of IP and Spec of CP in Spanish Wh-Questions," in W. Ashby, M. Mithun, G. Perissinotto, & E. Raposo (eds.), *Linguistic Perspectives on the Romance Languages*, Amsterdam: John Benjamins, 199-209.
- Goodall, Grant (1999): "On Preverbal Subjects in Spanish," in T. Satterfield, C. M. Tortora, & D. Cresti (eds.), *Current Issues in Romance Languages*, Amsterdam/Philadelphia: John Benjamins, 95-109.
- Goodall, Grant (2000): "What Spanish can tell us about the EPP," in M. Leonetti & O. Fernández Soriano (eds.), *Current Issues in Generative Grammar: Papers from the 10th Colloquium on Generative Grammar*, Universidad de Alcalá, 109-128.
- Grimshaw, Jane (1991): "Extended projections," Ms., Brandeis University
- Grohmann, Kleanthes (2003): *Prolific peripheries*, Amsterdam: John Benjamins.
- Grosu, Alexander & Julia Horvath (1984): "The GB Theory and raising in Rumanian," *Linguistic Inquiry* 15: 348-353.
- Guasti, M. Teresa (1996): "On the controversial status of Romance interrogatives," *Probus* 8: 161-180.
- Haegeman, Liliane (1998): "V-Positions and the Middle Field in West Flemish," *Syntax* 1: 259-299.
- Haegeman, Liliane (2002): "Anchoring to speaker, adverbial clauses, and the structure of CP," Ms. Université Charles de Gaulle - Lille III / CNRS.
- Hale, Ken & Samuel J. Keyser (1993): "On the argument structure and the lexical expression of syntactic relations," in K. Hale & S. Keyser (eds.), *The View from Building 20*, Cambridge (Mass.): MIT Press, 53-109.
- Hale, Ken & Samuel J. Keyser (1998): "The basic elements of argument structure," in *MIT Working papers in linguistics 32: Papers from the Upenn/ MIT Roundtable on Argument Structure*, Cambridge (Mass.): MIT Press, 73-118.
- Hale, Ken & Samuel J. Keyser (2002): *Prolegomenon to a Theory of Argument Structure*, Cambridge (Mass.): MIT Press.
- Halle, Morris & Alec Marantz (1993): "Distributed Morphology and the Pieces of Inflection," in K. Hale & S. Keyser (eds.), *The View from Building 20. Essays in Honor of Sylvain Bromberger*, Cambridge (Mass.): MIT Press, 111-176
- Harley, Heidi (1995): *Subjects, Events, and Licensing*, PhD dissertation, MIT.
- Harley, Heidi (2002): "A Minimal(ish) Linking Theory," Ms., University of Arizona.
- Harley, Heidi (2004): "Merge, conflation, and head movement: The First Sister Principle Revisited," in K. Moulton & M. Wolf (eds.), *Proceedings of NELS 34*, UMass Amherst: GLSA.
- Harley, Heidi (2005): "How Do Verbs Get Their Names? Denominal Verbs, Manner Incorporation, and the Ontology of Verbs Roots in English," in N. Erteschik-Shir & T. Rapoport (eds.), *The Syntax of Aspect: Deriving Thematic and Aspectual Interpretation*, Oxford (New York): Oxford University Press, 42-64.
- Harley, Heidi (2007): "External Arguments: On the Independence of Voice⁰ and v⁰," paper presented at GLOW XXX Conference, University of Tromsø, Tromsø.

- Harley, Heidi & Rolf Noyer (1999): "State-of-the-Article: Distributed Morphology," *Glott International* 4: 3-9.
- Harley, Heidi & Rolf Noyer (2000): "Licensing in the non-lexicalist lexicon," in B. Peeters (ed.), *The Lexicon/Encyclopaedia Interface*, Amsterdam: Elsevier, 349-374.
- Henry, Alison (1995): *Belfast English and Standard English. Dialect Variation and Parameter Setting*, New York (Oxford): Oxford University Press.
- Heycock, Caroline (1995): "Asymmetries in Reconstruction," *Linguistic Inquiry* 26: 547-170.
- Herburger, Elena (2000): *What Counts: Focus and Quantification*, Cambridge (Mass.): MIT Press.
- Hernanz, M. Lluïsa (1993): "A propósito de los adjuntos libres," in Viana, A. (ed.), *Sintaxi. Teoria i perspectives*, Lleida: Pagès, 125-173.
- Hernanz, M. Lluïsa (1994): "Concordancia, rección y aspecto: las construcciones absolutas en español," Alonso, A. et al. (eds.), *II Encuentro de lingüistas y filólogos de España y México*, Salamanca: Universidad de Salamanca, 367-402.
- Hernanz, M. Lluïsa (1999): "El infinitivo," I. Bosque & V. Demonte (eds.), *Gramática descriptiva de la lengua española*, Madrid: Espasa, 2197-2356.
- Hernanz, M. Lluïsa (2001): "¡En bonito lío me he metido!: Notas sobre la afectividad en español," *Moenia* 7: 93-109.
- Hernanz, M. Lluïsa (2003): "From polarity to modality: the case of *bien*," Ms., UAB.
- Hernanz, M. Lluïsa & José M. Brucart (1987): *La Sintaxis. Principios teóricos. La oración simple*, Barcelona: Crítica.
- Higginbotham, James (1985): "On Semantics," *Linguistic Inquiry* 16: 547-593.
- Higginbotham, James (1988): "Contexts, models, and meanings: a note on the data of semantics," in R. Kempson (ed.), *Mental representations*, Cambridge: Cambridge University Press, 29-48.
- Hinzen, Wolfram (2006): *Mind Design and Minimal Syntax*, Oxford (New York): Oxford University Press.
- Hiraiwa, Ken (2001a): "Multiple Agree and the Defective Intervention Constraint in Japanese," *MIT WPL* 40: 67-80.
- Hiraiwa, Ken (2001b): "On Nominative-Genitive Conversion," in O. Matushansky & E. Guerzoni (eds.), *A Few From Building E-39*. *MIT WPL* 39, Cambridge (Mass.): MITWPL, 66-123.
- Hiraiwa, Ken (2005): *Dimensions of Symmetry in Syntax: Agreement and Clausal Architecture*, PhD dissertation, MIT.
- Hirata, Ichiro (1997): "On apparent violation of the subject condition," *English Linguistics* 14: 342-347.
- Holmberg, Anders (1986): *Word order and syntactic features in the Scandinavian languages and English*. PhD dissertation, University of Stockholm.
- Holmberg, Anders (1999): "Remarks on Holmberg's Generalization," *Studia Linguistica* 53: 11-39.
- Holmberg, Anders (2005): "Is There a Little Pro? Evidence from Finnish," *Linguistic Inquiry* 36: 533-564.
- Hornstein, Norbert (1995): *Logical Form*, Oxford: Basil Blackwell
- Hornstein, Norbert (1999): "Minimalism and Quantifier Rising," in S. Epstein & N. Hornstein (eds.), *Working Minimalism*, Cambridge (Mass.): MIT Press, 45-75.
- Hornstein, Norbert (2001): *Move! A Minimalist Theory of Construal*. Oxford: Blackwell.
- Hornstein, Norbert (2003): "On Control," in R. Hendrick (ed.), *Minimalist Syntax*, Oxford: Blackwell, 6-81.
- Hornstein, Norbert (2005): "What do labels do?," Ms. UMD.
- Hornstein, Norbert (2006): "Pronouns in a Minimalist Setting," in N. Corver & J. Nunes (eds.), *The Copy Theory of Movement*, Amsterdam: John Benjamins, 351-385.
- Hornstein, Norbert, Howard Lasnik, & Juan Uriagereka (2006): "The dynamics of Islands," Ms., UMD.
- Hornstein, Norbert, Jairo Nunes & Paul Pietroski (2005): "Some Thoughts on Adjunction," Ms., UMD & Universidade de São Paulo.
- Hornstein, Norbert & Jairo Nunes (2006): "Some Thoughts on Adjunction," Ms., UMD & Universidade de São Paulo.

- Hornstein, Norbert & Itziar San Martín (in press): "Obviation as Anti-Control," *International Journal of Basque Linguistics and Philology (ASJU)*
- Hornstein, Norbert & Juan Uriagereka (2002): "Reprojections," in S. Epstein & T. Seely (eds.), *Derivation and Explanation in the Minimalist Program*, Malden (Mass.): Blackwell, 106-132.
- Hornstein, Norbert & Amy Weinberg (1981): "Case theory and preposition stranding," *Linguistic Inquiry* 12: 55-91.
- Huang, James (1982): *Logical relations in Chinese and the theory of grammar*, PhD dissertation, MIT.
- Huang, James (1993): "Reconstruction and the structure of VP: Some theoretical consequences," *Linguistic Inquiry* 24: 103-138.
- Iatridou, Sabine (1990): "On Agr(P)," *Linguistic Inquiry* 21: 241-459.
- Iatridou, Sabine (1993): "On Nominative Case Assignment and a Few Related Things," *MIT WPL* 19: 175-196.
- Iatridou, Sabine (2002): "Verb Movement in English and French 2. Iatridou's (1990) response to Pollock (1989)," HO, MIT.
- Irurtzun, Aritz (2003): "The Locus of [+F]ocus," Ms. EHU/UPV.
- Irurtzun, Aritz (2006): "Focus and Clause Structuration in the Minimalist Program," in C. Boeckx (ed.), *Minimalist Essays*, Amsterdam: John Benjamins, 68-96.
- Irurtzun, Aritz (2007): *The Grammar of Focus at the Interfaces*, PhD dissertation, Euskal Herriko Unibertsitatea.
- Jackendoff, Ray (1969): *Some rules of semantic interpretation in English*, PhD dissertation, MIT.
- Jackendoff, Ray (1977): *X-bar Syntax*, Cambridge (Mass.): MIT Press.
- Jaeggli, Osvaldo (1982): *Topics in Romance Syntax*, Foris: Dordrecht.
- Jaeggli, Osvaldo (1984): "Subject extraction and the Null Subject Parameter," *Proceedings of NELS 14*, 132-153.
- Jeong, Youngmi (2007): *Applicatives. Structure and interpretation from a minimalist perspective*, Amsterdam: John Benjamins.
- Johnson, Kyle (1985): *A Case for Movement*, PhD dissertation, MIT.
- Johnson, Kyle (2003): "Towards an Etiology of Adjunct Islands," A. Dahl, K. Bentzen & P. Svenonius (eds.), *Proceedings of the 19th Scandinavian Conference on Linguistics* (vol. 31.1.), 187-215.
- Kayne, Richard S. (1975): *French Syntax*. Cambridge (Mass.): MIT Press.
- Kayne, Richard S. (1984): *Connectedness and Binary Branching*. Dordrecht: Foris.
- Kayne, Richard S. (1989): "Null Subjects and Clitic Climbing," in O. Jaeggli & K. Safir (eds.), *The Null Subject Parameter*, Dordrecht: Kluwer, 239-261.
- Kayne, Richard S. (1991): "Romance Clitics, Verb Movement and PRO," *Linguistic Inquiry* 22: 647-686.
- Kayne, Richard S. (1994): *The Antisymmetry of Syntax*, Cambridge (Mass.): MIT Press.
- Kayne, Richard S. (1995): "Agreement and verb morphology in three varieties of English," in H. Hubert et al. (eds.), *Studies in comparative Germanic syntax*, Dordrecht: Kluwer: 159-167.
- Kayne, Richard S. (2000): *Parameters and Universals*, Oxford (New York): Oxford University Press
- Kayne, Richard S. (2002): "On some Prepositions that Look DP-internal: English *of* and French *de*," *Catalan Journal of Linguistics* 1: 71-115.
- Kayne, Richard S. & Jean-Yves Pollock (2001): "New thoughts on Stylistic Inversion," in A. Hulk & J.Y. Pollock (eds.), *Subject Inversion in Romance and the Theory of Universal Grammar*, Oxford (New York): Oxford University Press, 107-162.
- Kempchinsky, Paula (1987): *Romance Subjunctive Clauses and Logical Form*, PhD dissertation, University of California.
- Kempchinsky, Paula (1998): "Mood Phrase, Case Checking and Obviation," in A. Schwegler, B. Tranel, & M. Uribe-Etxebarria (eds.), *Romance Linguistics: Theoretical Perspectives*, Amsterdam: John Benjamins, 143-154.
- Kempchinsky, Paula (1999): "Binding in PPs in Spanish and the nature of Condition B," in J. Gutiérrez-Rexach & F. Martínez-Gil (eds.), *Advances in Hispanic Linguistics*:

- Papers from the 2nd Hispanic Linguistics Symposium (vol. 2)*, Cascadilla Press: Somerville (Mass.), 394-411.
- Kirsner, Robert (1973): "Natural Focus and Agentive Interpretation: On the Semantics of Dutch Expletive *er*," *Stanford Occasional Papers in Linguistics* 3: 101-114.
- Kitagawa, Yoshihisa (1986): *Subjects in Japanese and English*, PhD dissertation, UMass Amherst.
- Kitahara, Hisatsugu (1992): "Checking theory and scope interpretation without Quantifier Raising," *Harvard Working Papers in Linguistics* 1: 51-71.
- Kitahara, Hisatsugu (1996): "Raising quantifiers without quantifier raising," in W. Abraham et al. (eds.), *Minimal Ideas*, Amsterdam: John Benjamins, 189-198.
- Kitahara, Hisatsugu (1997): *Elementary operations and optimal derivations*, Cambridge (Mass.): MIT Press
- Koizumi, Masatoshi (1995): *Phrase Structure in Minimalist Syntax*, PhD dissertation, MIT.
- Koopman, Hilda (1983): "ECP effects in main clauses," *Linguistic Inquiry* 14: 346-350.
- Koopman, Hilda & Dominique Sportiche (1991): "The Position of Subjects," *Lingua* 85: 211-258
- Koster, Jan (2003): "All languages are tense second," Ms., University of Groningen.
- Kratzer, Angelika (1996): "Severing the External Argument from its Verb," in J. Rooryck & L. Zaring (eds.), *Phrase Structure and the Lexicon*, Dordrecht: Kluwer, 109-137.
- Kuno, Susumu (1973): "Constraints on Internal Clauses and Sentential Subjects," *Linguistic Inquiry* 4: 363-385.
- Kuroda, Yuki (1972): "The categorical and thethetic judgment," *Foundations of Language* 9: 153-185
- Laka, Itziar (1990): *Negation in Syntax: On the Nature of Functional Categories and Projections*, PhD dissertation, MIT.
- Landau, Idan (2004): "The Scale of Finiteness and the Calculus of Control," *Natural Language and Linguistic Theory* 22: 811-877.
- Larson, Richard (1988): "The Double Object Construction," *Linguistic Inquiry* 19: 335-391.
- Larson, Richard (2004): "Sentence-final adverbs and 'scope'," in M. Wolf & K. Moulton (eds.), *Proceedings of NELS 34*, U.Mass.: GLSA, 23-43.
- Lasnik, Howard (1999a): *Minimalist Analysis*, Oxford: Blackwell.
- Lasnik, Howard (1999b): "Pseudogapping puzzles," in S. Lappin & E. Benmamoun (eds.), *Fragments: Studies in Ellipsis and Gapping*, New York: Oxford University Press, 141-74.
- Lasnik, Howard (1999c): "Chains of arguments," in Epstein, S. & N. Hornstein (eds.), *Working minimalism*. Cambridge (Mass.), MIT Press, 189-215.
- Lasnik, Howard (2001a): "Subjects, Objects, and the EPP," in W. Davies & S. Dubinsky (eds.), *Objects and other subjects*, Dordrecht: Kluwer, 103-121.
- Lasnik, Howard (2001b): "When Can You Save a Structure by Destroying it?," *Proceedings of NELS 31*, 301-320.
- Lasnik, Howard (2002): "Clause-mate conditions revisited," *Glott International* 6: 94-96.
- Lasnik, Howard (2003a): *Minimalist investigations in linguistic theory*, London: Routledge.
- Lasnik, Howard (2003b): "Levels of Representation and the elements of Anaphora," in H. Lasnik, *Minimalist Investigations in Linguistic Theory*, New York: Routledge, 42-54.
- Lasnik, Howard (2006): "Conceptions of the Cycle," in L. Cheng & N. Corver (eds.), *Wh-movement: moving on*, Cambridge: MIT Press, 197-216.
- Lasnik, Howard & Cedric Boeckx (2006): "Long NP-Movement," in M. Everaert & H. van Riemsdijk (eds.), *The Blackwell Companion to Syntax (vol. 3)*, Oxford: Blackwell, 109-130.
- Lasnik, Howard & Myung-Kwan Park (2003): "The EPP and the subject condition under sluicing," *Linguistic Inquiry* 34, 649-660.
- Lasnik, Howard & Mamoru Saito (1984): "On the nature of proper government," *Linguistic Inquiry* 15: 235-289.

- Lasnik, Howard & Mamoru Saito (1992): *Move α : conditions on its applications and outputs*, Cambridge (Mass.): MIT Press.
- Lasnik, Howard & Mamoru Saito (1999): "On the Subject of infinitives," in H. Lasnik, *Minimalist Analysis*, Oxford: Blackwell, 7-24.
- Lasnik, Howard, Juan Uriagereka, & Cedric Boeckx (2005): *A Course in Minimalist Syntax. Foundations and Prospects*, Oxford: Blackwell.
- Law, Paul (2006): "Preposition Stranding," in M. Everaert & H. van Riemsdijk (eds.), *The Blackwell Companion to Syntax (vol. 3)*, Oxford: Blackwell, 631-684.
- Lebeaux, David (1983): "A Distributional Difference between Reciprocals and Reflexives," *Linguistic Inquiry* 14: 723-730.
- Lebeaux, David (1991): "Relative clauses, licensing, and the nature of the derivation," in S. Rothstein (ed.), *Perspectives on phrase structure: heads and licensing*, San Diego: Academic Press, 209-239.
- Lechner, Winfried (2005): "Interpretive Effects of Head Movement," Ms., University of Tuebingen.
- Legate, Julie Anne (2003): "Some Interface Properties of the phase," *Linguistic Inquiry* 34: 506-516.
- Leonetti, Manuel (1999): "El artículo," in I. Bosque & V. Demonte (eds.), *Gramática Descriptiva de la Lengua Española*, Madrid: Espasa, 787-890
- Leonetti, Manuel (2004): "Specificity and Differential Object Marking in Spanish," *Catalan Journal of Linguistics* 3: 75-114.
- Levin, Beth & Malka Rappaport (1995): *Unaccusativity. At the Syntax-Lexical Semantics Interface*, Cambridge (Mass.): MIT Press.
- Londhal, Terje (2006): "Labels and Linearization," Ms., University of Oslo.
- Longobardi, Giuseppe (1994): "Reference and Proper Names," *Linguistic Inquiry* 25: 609-665.
- Longobardi, Giuseppe (2000): "'Postverbal' Subjects and the Mapping Hypothesis," *Linguistic Inquiry* 31: 691-702.
- López, Luis (2002): "On Agreement: Locality and Feature Valuation," in A. Alexiadou (ed.), *Formal Approaches to Universals*, Amsterdam: John Benjamins, 165-209.
- López, Luis (2006): "The [person] restriction: why? And, most specially, why not?," in R. D'Alessandro et al. (eds.), *Agreement Restrictions*, Berlin: Mouton de Gruyter.
- Mahajan, Anoop (1992): "The Specificity Condition and the CED," *Linguistic Inquiry* 23: 510-516.
- Marantz, Alec (1984): *On the nature of grammatical relations*, Cambridge (Mass.): MIT Press.
- Marantz, Alec (1997): "No Escape from Syntax: Don't Try Morphological Analysis in the Privacy of Your Own Lexicon," in *U. Penn Working Papers in Linguistics* 4.2., 201-225.
- Marantz, Alec (2000): "Words," Ms., MIT.
- Martí, Luisa (2003): *Contextual Variables*, PhD dissertation, UConn.
- Martin, Roger & Juan Uriagereka (2000): "Introduction," in R. Martin, D. Michaels, & J. Uriagereka, *Step by Step. Essays on Minimalist Syntax in Honour of Howard Lasnik*, Cambridge (Mass.): MIT Press, 1-29.
- Marušič, Franc (2005): *On Non-Simultaneous Phases*, PhD dissertation, Stony Brook University.
- Masullo, Pascual J. (1992): "Quirky Datives in Spanish and the Non-Nominative Subject Parameter," in A. Kathol & J. Beckman (eds.), *MIT Working Papers in Linguistics* 16: 89-103.
- Masullo, Pascual J. (1993): "Two Types of Quirky Subjects: Spanish versus Icelandic," *Proceedings of NELS* 23, 303-317.
- Masullo, Pascual J. (2005): "The syntax-lexical semantics interface: prepositionalizing motion verbs in Spanish," paper presented in the *GGT Seminar*, UAB, April 7 2005.
- Mateu, Jaume (2002): *Argument Structure: Relational construal at the syntax-semantics interface*, PhD dissertation, UAB.

- Mateu, Jaume (2005): "Impossible Primitives," in M. Werning et al. (eds.), *The Composition of Meaning and Content: Foundational Issues. Linguistics & Philosophy Series (vol. I)*: Ontos, 213-229.
- Mateu, Jaume (2006): "On the I-syntax of directionality/resultativity: the case of Germanic preverbs," Ms., UAB.
- Matushansky, Ora (2003): "DPs and Phase Theory," HO UiL OTS.
- Matushansky, Ora (2006): "Head movement in linguistic theory," *Linguistic Inquiry* 37: 69-109.
- Mayr, Clemens (2005): "On the Necessity of T," Ms., Harvard University.
- Mayr, Clemens (2006a): "On the Necessity of T and ϕ -features: The Case of Babarian Subject Extraction," Ms., Harvard University.
- Mayr, Clemens (2006b): "Specifiers, Adjuncts, and Pied-Piping," Ms., Harvard University.
- Mayr, Clemens (2007): "Subject-Object Asymmetries and the Relation Between Internal Merge and Pied-Piping," Ms., Harvard University.
- McCloskey, James (2000): "Quantifier float and *wh*-movement in an Irish English," *Linguistic Inquiry* 31: 57-84.
- McDonald, Jonathan (2006): *The Syntax of Inner Aspect*, PhD dissertation, CUNY - Stony Brook University.
- McGinnis, Martha (2000): "Event heads and the distribution of psych-roots," in A. Williams & E. Kaiser (Eds.), *Current work in linguistics: University of Pennsylvania WPL* 6: 107-144.
- McGinnis, Marta (2004): "Lethal Ambiguity," *Linguistic Inquiry* 35: 47-95.
- Mendikoetxea, Amaya (1997): "Clitics as AGR, and pro in finite clauses," in N. Català & M. Bargalló (eds.), *Proceedings of IV Colloquium on Generative Grammar*, Tarragona: Servicio de Publicaciones de la Universitat Rovira i Virgili, 84-121.
- Merchant, Jason (2001): *The syntax of silence: sluicing, islands, and the theory of ellipsis*, Oxford: Oxford University Press.
- Miguel, Elena de (1992): *El aspecto en la sintaxis del español: perfectividad e impersonalidad*, PhD dissertation, Universidad Autónoma de Madrid.
- Mioto, Carlos (1998): "A periferia esquerda no Português Brasileiro," Ms., Universidade Federal de Santa Catarina - University of Siena.
- Miyagawa, Shigeru (2004): "On the EPP," in N. Richards & M. McGinnis (eds.), *Proceedings of the EPP/Phase Workshop*, Cambridge (Mass.): MIT Press.
- Miyagawa, Shigeru (2005): "Unifying Agreement and Agreement-less Languages," Ms., MIT. [to appear in MIT WPL]
- Moro, Andrea (1997): *The Raising of Predicates. Predicative Noun Phrases and the Theory of Clause Structure*, Cambridge (New York): Cambridge University Press.
- Moro, Andrea (2000): *Dynamic Antisymmetry. Movement as a symmetry breaking phenomenon*, Cambridge (Mass.): MIT Press.
- Moro, Andrea (2006): "Some Notes on Unstable Structures," Ms., Università San Raffaele di Milano.
- Müller, Gereon (2004): "Phrase impenetrability and *wh*-intervention," in A. Stepanov et al. (eds.), *Minimality Effects in Syntax*, Berlin: Mouton de Gruyter, 289-325.
- Muysken, Pieter (1982): "Parametrizing the notion of 'head'," *Journal of Linguistic Research* 2: 57-75.
- Nevins, Andrew (2004): "Derivations without the Activity Condition," in M. McGinnis & N. Richards (eds.), *Perspectives on Phases. MIT WPL* 49, 287-310.
- Nevins, Andrew & Pranav Anand (2003): "Some AGREEMENT matters," in G. Garding & M. Tsujimura (eds.), *WCCFL 22 proceedings*, 370-383.
- Nilsen, Øistein (1999): *Eliminating Positions: Syntax and semantics of sentence modification*, PhD dissertation, University of Utrecht.
- Nissenbaum, Jonathan (2000): *Investigations of Covert Phrase Movement*, PhD dissertation, MIT.
- Nunes, Jairo (2001): "Sideward Movement," *Linguistic Inquiry*, 32, 304-344.
- Nunes, Jairo (2004): *Linearization of Chains and Sideward Movement*, Cambridge (Mass.): MIT Press.

- Ono, Hajime (2006): *An Investigation of Exclamatives in English and Japanese: Syntax and Sentence Processing*, PhD dissertation, UMD.
- Ordóñez, Francisco (1997): *Word Order and Clause Structure in Spanish and Other Romance Languages*, PhD dissertation, City University of New York.
- Ordóñez, Francisco (1998a): "The inversion construction in interrogatives in Spanish and Catalan," in J. Lema & E. Treviño (eds.), *Theoretical analyses on Romance languages*. Amsterdam: John Benjamins, 329-350.
- Ordóñez, Francisco (1998b): "Post-verbal asymmetries in Spanish," *Natural Language and Linguistic Theory* 16: 313-346.
- Ordóñez, Francisco (2005): "Two Specs for postverbal subjects: Evidence from Spanish and Catalan," Ms. SUNY Stony Brook.
- Ordóñez, Francisco & Esthela Treviño (1999): "Left Dislocated Subjects and the pro-drop Parameter: A Case Study of Spanish," *Lingua* 107: 39-68.
- Ordóñez, Francisco & Antxon Olarrea (2005): "Microvariation in Caribbean/non Caribbean Spanish Interrogatives," Ms. SUNY Stony Brook/U.Arizona.
- Ormazabal, Javier (1992): "Asymmetries on Wh-movement and Specific DP-s," in J.A. Lakarra y J. Ortiz de Urbina (eds.), *Syntactic Theory and Basque Syntax, International Journal of Basque Linguistics and Philology* 27: 273-294.
- Ormazabal, Javier (2000): "A Conspiracy Theory of Case and Agreement," in R. Martin, D. Michaels, & J. Uriagereka, *Step by Step. Essays on Minimalist Syntax in Honour of Howard Lasnik*, Cambridge (Mass.): MIT Press, 235-260.
- Ormazabal, Javier (2005): "The syntactic distribution of factive complements," Ms., EHU.
- Ormazabal, Javier, Juan Uriagereka & Myriam Uribe-Etxebarria (1994): "Word order and wh-movement: towards a parametric account," Ms. UConn/UPV-EHU/UMD/MIT.
- Ortega-Santos, Iván (2002): "Overt Subjects of Infinitives in Spanish: Abstract Agreement and the EPP," in the *Selected Proceedings of the 12th Annual Graduate and Professional Symposium on Hispanic and Luso-Brazilian Literature, Language and Culture* at the University of Arizona.
- Ortega-Santos, Iván (2005): "On Postverbal Subjects, PF and the Copy Theory: The Spanish Case," Ms. UMD.
- Parsons, Terence (1990): *Events in the semantics of English*. Cambridge (Mass.), MIT Press.
- Pesetsky, David (1987): "Wh-in-situ: Movement and Unselective Binding," in E. Reuland & A.G.B. ter Meulen (eds.), *The Linguistic Representation of (In)definiteness*, Cambridge (Mass.): MIT Press.
- Pesetsky, David (1995). *Zero Syntax. Experiencers and Cascades*, Cambridge (Mass.): MIT Press.
- Pesetsky, David (1998): "Some Optimality Principles of Sentence Pronunciation," *Is the Best Good Enough?: Optimality and Competition in Syntax*, in P. Barbosa et al. (eds.), Cambridge (Mass.): MIT Press, 337-383.
- Pesetsky, David (2000): *Phrasal Movement and Its Kin*, Cambridge (Mass.): MIT Press.
- Pesetsky, David (2007): "Property Delay (Remarks on "Phase Extension" by Marcel Den Dikken)," *Theoretical Linguistics* 33: 105-120.
- Pesetsky, David & Esther Torrego (2001): "T-to-C Movement: Causes and Consequences," in M. Kenstowicz (ed.), *Ken Hale: A Life in Language*, Cambridge (Mass.): MIT Press, 355-426.
- Pesetsky, David & Esther Torrego (2004): "Tense, Case, and the Nature of Syntactic Categories," in J. Guéron & J. Lecarme (eds.), *The Syntax of Time*, Cambridge (Mass.): MIT Press, 495-537.
- Pesetsky, David & Esther Torrego (2006): "Probes, Goals, and the Nature of Syntactic Categories," in Y. Otsu (ed.), *Proceedings of the Seventh Tokyo Conference on Psycholinguistics*, Tokyo: Hituzi Syobo Publishing Company, 25-60.
- Pesetsky, D. & E. Torrego (2007): "The Syntax of Valuation and the Interpretability of Features," in S. Karimi et al (eds.), *Phrasal and Clausal Architecture. Syntactic Derivation and Interpretation*, Amsterdam: John Benjamins, 262-294.

- Picallo, M. Carme (1984): "The Infl node and the null subject parameter," *Linguistic Inquiry* 15: 75-102.
- Picallo, M. Carme (1985): *Opaque Domains*, PhD dissertation, City University of New York.
- Picallo, M. Carme (1990): "Modal Verbs in Catalan," *Natural Language and Linguistic Theory* 8: 285-312.
- Picallo, M. Carme (1998): "On the EPP and Null Expletive Subjects," *Probus* 10: 219-241.
- Picallo, M. Carme (2002): "Abstract Agreement and Clausal Arguments," *Syntax* 5: 116-147.
- Platzack, Christer (2003): "Agreement and Null Subjects," *Nordlyd*, 31, 326-355.
- Poletto, Cecilia (2001): "Complementizer deletion and verb movement in standard Italian," in C. Cinque & G. Salvi (eds.), *Current studies in Italian syntax. Essays offered to Lorenzo Renzi*, Amsterdam: Elsevier, 265-286.
- Poletto, Cecilia & Jean-Yves Pollock (2004): "On the Left Periphery of Some Romance Wh-Questions," in L. Rizzi (ed.), *The Structure of CP and IP. The Cartography of Syntactic Structures (vol. 2)*, Oxford (New York): Oxford University Press, 251-296.
- Pollock, Jean-Yves (1989): "Verb Movement, Universal Grammar, and the Structure of IP," *Linguistic Inquiry*, 20, 365-424.
- Pollock, Jean-Yves (1997): *Language et Cognition. Introduction au programme minimaliste de la grammaire générative*. Paris: Presses Universitaires de France.
- Postal, Paul (1974): *On Raising: one rule of English grammar and its theoretical implications*, Cambridge (Mass.): MIT Press.
- Rackowski, Andrea & Norvin Richards (2005): "Phase Edge and Extraction: A Tagalog Case Study," *Linguistic Inquiry* 36: 565-599.
- Raposo, Eduardo (1986): "On the null object in European Portuguese," in O. Jaeggli & C. Silva-Corvalán (eds.), *Studies in Romance linguistics*, Dordrecht: Foris, 373-390.
- Raposo, Eduardo (1987): "Romance Inversion, the Minimality Condition and Theta-theory and the ECP," *Proceedings of NELS 18*.
- Raposo, Eduardo (2002): "Nominal Gaps with Prepositional Modifiers in Portuguese and Spanish: A Case of Quick Spell-Out," *Cuadernos de Lingüística del Instituto Universitario Ortega y Gasset* 9: 127-144.
- Raposo, Eduardo & Juan Uriagereka (1995): "Two Types of Small Clauses," in A. Cardinaletti & M.T. Guasti (eds.), *Syntax and Semantics: Small Clauses (vol. 28)*, London: Academic Press, 179-206.
- Raposo, Eduardo & Juan Uriagereka (1996): "Indefinite SE," *Natural Language and Linguistic Theory*, 14, 749-810.
- Raposo, Eduardo & Juan Uriagereka (2002): "Two Types of Small Clauses," in J. Uriagereka (2002a), 212-234.
- Raposo, Eduardo & Juan Uriagereka (2005): "Clitic Placement in Western Iberian: A Minimalist View," in G. Cinque & R.S. Kayne (eds.), *The Oxford Handbook of Comparative Syntax*, Oxford (New York): Oxford University Press, 639-697.
- Real, Cristina (2006): *La classe dels verbs de mesura: un cas de verbs fronterers*, Master Thesis, UAB.
- Reinhart Tanya & Eric Reuland (1993): "Reflexivity," *Linguistic Inquiry* 24: 657-720
- Reuland, Eric (2001): "Primitives of Binding," *Linguistic Inquiry* 32: 439-492.
- Reuland, Eric (2006a): "Binding Theory: Terms and Concepts," in M. Everaert and H. Van Riemsdijk (eds.), *The Blackwell Companion to Syntax (vol. 1)*, Malden: Blackwell, 260-283.
- Reuland, Eric (2006b): "Agreeing to bind," Ms., Utrecht institute of Linguistics OTS
- Richards, Marc (2004): *Object Shift and Scrambling in North and West Germanic: A Case Study in Symmetrical Syntax*, PhD dissertation, University of Cambridge.
- Richards, Marc D. (2006a): "Deriving the Edge: What's in a Phase?," Ms., University of Cambridge.
- Richards, Marc D. (2006b): "Dynamic Linearization and the Shape of Phases," Ms., University of Cambridge,

- Richards, Marc D. (2006c): "Weak pronouns, object shift, and multiple spell-out: Evidence for phases at the PF-interface," in C. Boeckx (ed.), *Minimalist Essays*, Amsterdam: John Benjamins, 160-181.
- Richards, Marc D. (2007): "On Feature Inheritance: An Argument from the Phase Impenetrability Condition," *Linguistic Inquiry* 38: 563-572.
- Richards, Norvin (1997): *What Moves Where When in Which Language?*, PhD dissertation, MIT.
- Richards, Norvin (1998): "The Principle of Minimal Compliance," *Linguistic Inquiry* 29: 599-629.
- Richards, Norvin (2002): "Very local A' Movement in a Root-first Derivation," in S. Epstein & T. Seely (eds.), *Derivation and Explanation in the Minimalist Program*, Malden (Mass.): Blackwell, 227-248.
- Richard, Norvin (2004): "Against Bans on Lowering," *Linguistic Inquiry* 35: 453-463.
- Riemsdijk, Henk van (1978): *A case Study in Syntactic Markedness: The Binding Nature of Prepositional Phrases*, Lisse: The Peter de Ridder Press.
- Riemsdijk, Henk van & Edwin Williams (1981): "NP-structure," *Linguistic Review* 1: 171-217.
- Rigau, Gemma (1986): "Some remarks on the nature of strong pronouns in null-subject languages," in I. Bordelais, H. Contreras & K. Zagana (eds.), *Generative studies in Spanish syntax*, Dordrecht: Foris, 143-163.
- Rigau, Gemma (1988): "Strong pronouns," *Linguistic Inquiry* 19: 503-511.
- Rigau, Gemma (1995): "The properties of the temporal infinitive constructions in Catalan and Spanish," *Probus* 7: 279-301.
- Rigau, Gemma (1998): "On Temporal and Causal Infinitive Constructions in Catalan Dialects," *Catalan Working Papers in Linguistics* 6: 95-114.
- Rivero, M. Luisa (1994): "Negation, imperatives, and Wackernagel effects," *Rivista di linguistica* 6: 91-118.
- Rivero, M. Luisa (2004): "Spanish Quirky Subjects, Person Restrictions and the PCC," *Linguistic Inquiry* 35: 494-502
- Rivero, M. Luisa (2006): "Oblique subjects and person restrictions in Spanish: A morphological approach," in R. D'Alessandro et al. (eds.), *Agreement Restrictions*, Berlin: Mouton de Gruyter.
- Rizzi, Luigi (1978): "Violations of the Wh-Island Constraint in Italian and the Subjacency Condition," *Montreal Working Papers in Linguistics*, 11, 155-190.
- Rizzi, Luigi (1982): *Issues in Italian Syntax*, Dordrecht: Foris.
- Rizzi, Luigi (1986a): "On Chain Formation," in H. Borer (ed.), *Syntax and Semantics (vol. 19). The Syntax of Pronominal Clitics*, Academic Press, 65-95.
- Rizzi, Luigi (1986b): "On the status of subject clitics in Romance," in O. Jaeggli & C. Silva-Corvalán (eds.), *Studies in Romance Syntax*, Dordrecht: Foris, 391-419.
- Rizzi, Luigi (1986c): "Null objects in Italian and the theory of *pro*," *Linguistic Inquiry* 17: 501-557.
- Rizzi, Luigi (1990): *Relativized Minimality*, Cambridge (Mass.): MIT Press.
- Rizzi, Luigi (1991): "On the Status of Referential Indices," in A. Kasher (ed.), *The Chomskyan Turn*, Oxford: Blackwell.
- Rizzi, Luigi (1992): "Argument/adjunct (a)symmetries," in *Proceedings of NELS 22*, Amherst (Mass.): GLSA, 365-381. [reprinted in Rizzi (2000)]
- Rizzi, Luigi (1994): "Early null subjects and root null subjects," in T. Hoekstra & B. Schwartz (eds.), *Language Acquisition Studies in Generative Grammar*, Amsterdam: John Benjamins, 151-176.
- Rizzi, Luigi (1996): "Residual verb second and the *wh*-criterion," in A. Belletti & L. Rizzi (eds.), *Parameters and functional heads: essays in comparative syntax*, Oxford: Oxford University Press.
- Rizzi, Luigi (1997): "The Fine Structure of The Left Periphery," in L. Haegeman (ed.), *Elements of Grammar. Handbook in Generative Syntax*, Dordrecht: Kluwer: 281-337.
- Rizzi, Luigi (1999): "On the Position "Int(errogative)" in the Left Periphery of the Clause," Ms. Università di Siena. [reprinted in G. Cinque & G. Salvi (eds.),

- Current studies in Italian Syntax. Essays offered to Lorenzo Renzi*, Amsterdam: Elsevier. 2001]
- Rizzi, Luigi (2000): *Comparative Syntax and Language Acquisition*, London: Routledge.
- Rizzi, Luigi (2001a): "On the position "Int(errogative)" in the left periphery of the clause," in G. Cinque & G. Salvi (eds.), *Current Studies in Italian Syntax offered to Lorenzo Renzi*, Amsterdam: Elsevier, 287-296.
- Rizzi, Luigi (2001b): "Reconstruction, Weak Island Sensitivity, and Agreement," in C. Cecchetto, G. Chierchia & M. T. Guasti (eds.), *Semantic Interfaces*, Stanford (CA): CSLI, 145-176. Ms., U. Siena.
- Rizzi, Luigi (2004): "Locality and Left Periphery," in A. Belletti (ed.), *Structures and Beyond. The Cartography of Syntactic Structures (vol. 3)*, Oxford (New York): Oxford University Press, 223-251.
- Rizzi, Luigi (2006a): "On the Form of Chains: Criterial Positions and ECP Effects," in L. Cheng & N. Corver (eds.), *Wh-Movement: Moving on*. Cambridge, MIT Press, 97-133.
- Rizzi, Luigi (2006b): "Criterial Freezing, EPP and Asymmetries," paper presented at *Edges in Syntax*, Cyprus College, Nicosia (Cyprus).
- Rizzi, Luigi & Ur Slonshky (2007): "Strategies of Subject Extraction," in U. Sauerland & H-M. Gärtner (eds.), *Interfaces + Recursion = Language? Chomsky's minimalism and the view from syntax-semantics*, Berlin: Mouton de Gruyter, 115-160.
- Roberts, Ian G. (1994): "Two types of verb movement in Romance," in D. Lightfoot & N. Hornstein (eds.), *Verb Movement*, Cambridge: Cambridge University Press, 207-242.
- Roberts, Ian G. (2006): "Clitics, Head Movement, and Incorporation," Ms., University of Cambridge.
- Rosselló, Joana (2000): "A Minimalist Approach to the Null Subject Parameter," *Catalan WPL* 8: 97-128.
- Sabel, Joachim (2002): "A Minimalist Analysis of Syntactic Islands," *The Linguistic Review* 19: 271-315.
- Sag, Ivan & Thomas Wasow (1999): *Syntactic Theory. A Formal Introduction*, Stanford (California): CSLI Publications.
- Salanova, Andrés Pablo (2002): "Inversion in Spanish interrogatives," Ms., MIT.
- Salles, Heloisa (2001): "Aspectos da sintaxe de clíticos e artigos em português," *Revista Letras* 56: 177-191.
- Sánchez López, Cristina (1999): "La negación," in I. Bosque & V. Demonte (eds.), *Gramática Descriptiva de la Lengua Española*, Madrid: Espasa, 2561-2634.
- San Martín, Itziar (2004): *On Subordination and the Distribution of PRO*, PhD dissertation, UMD.
- San Martín, Itziar (2007): "Beyond the Infinitive vs. Subjunctive Rivalry: Surviving changes in Mood," in L. Eguren & O. Fernández-Soriano (eds.), *Selected Papers from XVI Colloquium on Generative Grammar*, Amsterdam: John Benjamins, 171-190.
- Sigurðsson, Halldór (1996): "Icelandic finite verb agreement," *Working Papers in Scandinavian Syntax* 57: 1-46.
- Sigurðsson, Halldór (2000): "The Locus of Case and Agreement," *Working Papers in Scandinavian Syntax*, 65, 65-108.
- Sigurðsson, Halldór (2003): "Case: Abstract vs. Morphological," in E. Brandner & H. Zinzmeister (eds.), *New Perspectives on Case Theory*, Stanford: CSLI Publications, 223-268.
- Sigurðsson, Halldór (2006): "The Nominative Puzzle and the Low Nominative Hypothesis," *Linguistic Inquiry* 37: 289-308.
- Simoni, María Elena (2003): "Una clase de verbos preposicionales en la interficie léxico-sintaxis," *Cuadernos IUOG* 12: 77-88.
- Sugisaki, Koji (2002): *Innate Constraints on Language Variation: Evidence from Child Language*, PhD dissertation, University of Connecticut.
- Solà, Jaume (1992): *Agreement and Subjects*, PhD dissertation, UAB.
- Solà, Jaume (2002): "Clitic Climbing and Null Subject Languages," *Catalan Journal of Linguistics* 1: 225-255.

- Sportiche, Dominique (1981): "Bounding Nodes in French," *The Linguistic Review* 1: 219-246.
- Sportiche, Dominique (1988): "A theory of floating quantifiers and its corollaries for constituent structure," *Linguistic Inquiry* 19: 425-449.
- Sportiche, Dominique (1998): *Partitions and Atoms of Clause Structure*, London: Routledge.
- Starke, Michael (2001): *Move Dissolves into Merge: A Theory of Locality*, PhD dissertation, University of Geneva.
- Starke, Michael (2004): "On the inexistence of specifiers and the natures of heads," Belletti, A. (ed.), *Structures and Beyond. The Cartography of Syntactic Structures* (vol. 3). Oxford, Oxford University Press, 252-268.
- Stepanov, Arthur (2001): *Cyclic Domains in Syntactic Theory*, PhD dissertation, UConn.
- Stepanov, Arthur (2002): "Derivational Properties of Inherent Case," Ms., Universität Potsdam.
- Stjepanović, Sandra (1999): *What do Second Position Clitization, Scrambling and Multiple Wh-fronting have in common?*, PhD dissertation, UConn.
- Stjepanović, Sandra (2003): "A word order paradox resolved by copy deletion at PF," P. Pica (ed.). *Linguistic Variation Yearbook 2003*, Amsterdam: John Benjamins, 139-177.
- Stowell, Tim (1981): *The origins of phrase structure*, PhD dissertation, MIT.
- Stowell, Tim (1982): "The Tense of Infinitives," *Linguistic Inquiry* 13: 561-570.
- Stowell, Timothy (1996): "The Phrase Structure of Tense," in J. Rooryck & L. Zaring (eds.), *Phrase Structure and the Lexicon*, Dordrecht: Kluwer, 277-291.
- Stroik, Thomas (1999): "Middles and Reflexivity," *Linguistic Inquiry* 30: 119-131.
- Suñer, Margarita (1991): "Indirect Questions and the Structure of CP," in H. Campos & F. Martinez-Gil (eds.), *Current Studies in Spanish Linguistics*: Georgetown University Press, 283-312.
- Suñer, Margarita (1994): "V-Movement and the Licensing of Argumental Wh-Phrases in Spanish," *Natural Language and Linguistic Theory*, 12, 335-372.
- Suñer, Margarita (1999): "La subordinación sustantiva: la interrogación indirecta," in I. Bosque & V. Demonte (eds.), *Gramática descriptiva de la lengua española*, Madrid: Espasa, 2149-2195.
- Suñer, Margarita (2003): "The lexical preverbal subject in a Romance null subject language: Where art thou?," in R. Núñez-Cedeño et al. (eds.), *A Romance perspective on language knowledge and use: Selected papers from the 31st Linguistic Symposium on Romance Languages (LSRL), Chicago, 19-22 April 2000*, Amsterdam: John Benjamins, 22-38.
- Svenonius, Peter (2001): "Case and Event Structure," in N. Zhang (ed.), *ZAS WPL* 26, Berlin: ZAS.
- Svenonius, Peter (2002a): "Case is uninterpretable aspect," Ms. U.Trømso.
- Svenonius, Peter (2002b): "Icelandic Case and the Structure of Events," *Journal of Comparative Linguistics* 1: 197-225.
- Svenonius, Peter (2004): "On the Edge," in D. Adger et al. (eds.), *Peripheries: Syntactic Edges and their Effects*, Dordrecht: Kluwer, 259-287.
- Szabolcsi, Anna (1992): "Subordination: Articles and Complementizers," in I. Kenesei & Cs. Pléh (eds.), *Approaches to Hungarian, Vol.4: The Structure of Hungarian*, Szeged: JATE, 123-137.
- Talmy, Leonard (2000): *Towards a Cognitive Semantics*, Cambridge (Mass.): MIT Press.
- Takahashi, Daiko (1994): *Minimality of Movement*, PhD dissertation, UConn.
- Taraldsen, Knut Tarald (1980): *On the nominative island condition, vacuous application and the that-trace filter*, Bloomington (Ind): Indiana university Linguistics club.
- Tenny, Carol (1994): *Aspectual roles and the syntax-semantics interface*. Dordrecht, Kluwer.
- Tellier, Christine (1990): "Subjacency and Subject Condition Violation in French," *Linguistic Inquiry* 21: 306-311.
- Ticio, M. Emma (2005): "Locality and Anti-locality in Spanish DPs," *Syntax* 8: 229-286.
- Torrego, Esther (1980): "Fronting in Spanish," Ms., University of Massachusetts at Boston.

- Torrego, Esther (1983): "More Effects of Successive Cyclic Movement," *Linguistic Inquiry* 14: 361-365.
- Torrego, Esther (1984): "On Inversion in Spanish and Some of Its Effects," *Linguistic Inquiry* 15: 103-129.
- Torrego, Esther (1985): "On Empty Categories in Nominals," Ms., U.Mass Boston.
- Torrego, Esther (1989): "Unergative-Unaccusative Alternations in Spanish," *MIT WPL* 10: 253-272.
- Torrego, Esther (1994): "Cómo," in V. Demonte (ed.), *Gramática del español*, México, Colegio de México: Publicaciones de la NRFH VI, 255-266.
- Torrego, Esther (1995a): "On the nature of clitic doubling," in H. Campos & P. Kempchinsky (eds.), *Evolution and revolution in linguistic theory*, Washington DC: Georgetown University Press, 399-418.
- Torrego, Esther (1995b): "From argumental to non-argumental pronouns: Spanish doubled reflexives," *Probus* 7: 221-241.
- Torrego, Esther (1996a): "On Quantifier Float in Control Clauses," *Linguistic Inquiry*, 27, 111-126.
- Torrego, Esther (1996b): "Experiencers and Raising Verbs," in R. Freidin (ed.), *Current Issues in Comparative Grammar*, Dordrecht: Kluwer, 101-120.
- Torrego, Esther (1998a): *The Dependencies of Objects*, Cambridge (Mass.): MIT Press.
- Torrego, Esther (1998b): "Nominative subjects and PRO-drop INFL," *Syntax* 1: 206-219.
- Torrego, Esther (1999): "Aspect in the prepositional system of Romance," in T. Satterfield et al. (eds.), *Current Issues in Romance Languages*, Amsterdam: John Benjamins, 337-357.
- Torrego, Esther (2002): "Arguments for a Derivational Approach to Syntactic Relations Based on Clitics," in S. Epstein & T. Seely (eds.), *Derivation and Explanation in the Minimalist Program*, Malden (Mass.): Blackwell, 249-268.
- Torrego, Esther & Juan Uriagereka (1992): "Indicative Dependents," Ms. U.Mass Boston/UMD.
- Travis, Lisa (1984): *Parameters and effects of word order variation*, PhD dissertation, MIT.
- Treviño, Esther (1994): *Las Causativas del Español con Complemento Infinitivo*, Estudios de Lingüística y Literatura, XXVII, El Colegio de México, México, D.F.
- Ura, Hiroyuki (1996): *Multiple feature checking: A theory of grammatical function splitting*, PhD dissertation, MIT.
- Uriagereka, Juan (1988a): *On Government*, PhD dissertation, UConn.
- Uriagereka, Juan (1988b): "Different Strategies for Eliminating Barriers," *Proceedings of NELS* 18.
- Uriagereka, Juan (1993): "Specificity and the Name constraint," *UMD WPL* 1: 121-143.
- Uriagereka, Juan (1995a): "An F Position in Western Romance," in K. Kiss (ed.), *Discourse configurational languages*, Oxford (New York): Oxford University Press, 153-175.
- Uriagereka, Juan (1995b): "Aspects of the syntax of clitic placement in Western Romance," *Linguistic Inquiry* 26: 79-123
- Uriagereka, Juan (1997): "Formal and Substantive Elegance in the Minimalist Program," in M. Bierwisch et al. (eds.), *The role of economy principles in linguistic theory*, Berlin: Akademie Verlag, 170-204. [reprinted in Uriagereka 2002: 86-114].
- Uriagereka, Juan (1998): *Rhyme and Reason*. Cambridge (Mass.): MIT Press.
- Uriagereka, Juan (1999a): "Multiple Spell-Out," in N. Hornstein & S. Epstein (eds.), *Working Minimalism*, Cambridge (Mass.): MIT Press, 251-282. [reprinted in Uriagereka 2002a: 45-65]
- Uriagereka, Juan (1999b): "Minimal Restrictions on Basque Movements," *Natural Language and Linguistic Theory* 17: 403-444. [reprinted in Uriagereka 2000: 86-114]
- Uriagereka, Juan (2001): "Doubling and Possession," in B. Gerlach & J. Grijzenhout (ed.), *Clitics in Phonology, Morphology and Syntax*, Amsterdam/Philadelphia: John Benjamins, 405-431.
- Uriagereka, Juan (2002a): *Derivations. Exploring the Dynamics of Syntax*, London: Routledge.
- Uriagereka, Juan (2002b): "Evidential contexts," Ms., UMD.

- Uriagereka, Juan (2003): "Pure Adjuncts," Ms., UMD.
- Uriagereka, Juan (2004): "Spell-Out Consequences," Ms., UMD.
- Uriagereka, Juan (2005a): "On the Syntax of Doubling," in L. Heggie & F. Ordóñez (eds.), *Clitic and Affix Combinations: Theoretical Perspectives*, Amsterdam: John Benjamins, 343-374.
- Uriagereka, Juan (2005b): "A Markovian Syntax for Adjuncts," Ms. UMD.
- Uriagereka, Juan (2006): "Complete and Partial Infl," in C. Boeckx (ed.), *Agreement Systems*, Amsterdam: John Benjamins, 267-298.
- Uriagereka, Juan (forthcoming): *Syntactic Anchors at the Semantic Interface*, Cambridge, Cambridge University Press.
- Uriagereka, Juan & Ángel J. Gallego (in progress): "(Multiple) Agree as Local (Binding and) Obviation," Ms., UAB-UMD.
- Uribe-Etxebarria, Myriam (1992): "On the Structural Positions of the Subject in Spanish, their Nature and their Consequences for Quantification," in J. Lakarra & J. Ortiz de Urbina (eds.), *Syntactic Theory and Basque Syntax*, San Sebastián: ASJU, 447-491.
- Uribe-Etxebarria, Myriam (1994): *Interface Licensing Conditions on Negative Polarity Items: A Theory of Polarity and Tense Interactions*, PhD dissertation, UConn.
- Uribe-Etxebarria, Myriam (1995): "On the structure of SPEC/IP and its relevance for scope asymmetries," in J. Amastae et al. (eds.), *Contemporary Research in Romance Linguistics*, Amsterdam: John Benjamins, 355-367.
- Vallduví, Enric (1990): *The Informational Component*, PhD dissertation, University of Pennsylvania.
- Vicente, Luis (2007): *The syntax of heads and phrases. A study of verb (phrase) fronting*, PhD dissertation, University of Leiden.
- von Stechow, Kai (1994): *Restrictions on Quantifier Domains*, PhD dissertation, University of Massachusetts, Amherst.
- Watanabe, Akira (1995): "Conceptual Basis of Cyclicity," in R. Pensalfini & H. Ura (eds.), *MIT WPL 27*: 269-291.
- Watanabe, Akira (2000): "Feature Copying and Binding: Evidence from Complementizer Agreement and Switch Reference," *Syntax 3*: 159-181.
- Wexler, Kenneth & Peter Culicover (1981): *Formal principles of language acquisition*, Cambridge (Mass.): MIT Press.
- Wurmbrand, Susi (2001): *Infinitives: Restructuring and clause structure*, Berlin: Mouton de Gruyter.
- Wurmbrand, Susi (2005): "Tense in infinitives," plenary speaker at the workshop on *New Horizons in the Grammar of Raising and Control*, LSA Summer Institute, Cambridge, Mass.
- Wurmbrand, Susi (2007): "Infinitives are Tenseless," *U.Penn WPL 13*: 1-14.
- Zubizarreta, M. Luisa (1998): *Prosody, focus, and word order*, Cambridge (Mass.): MIT Press.
- Zubizarreta, M. Luisa (1999): "The Cl(itic) Projection in Questions," *Catalan WPL 7*: 253-277.
- Zubizarreta, M. Luisa (2007): "The Left Edge in the Spanish Clausal Structure," paper presented at *Linguistics Symposium on Romance Languages 37*, University of Pittsburgh, Pittsburgh.
- Zwart, C. Jan-Wouter (1993): "Verb Movement and Complementizer Agreement," *MIT WPL*, 18.
- Zwart, C. Jan-Wouter (2001): "Syntactic and phonological verb movement," *Syntax 4*: 34-62.